

# STREAMLINE UNDERSINK

Fitting Instructions and User Guide

# CONTENTS

SECTION	PAGE
1.0 INTRODUCTION	3
2.0 TECHNICAL SPECIFICATIONS	4
3.0 INSTALLATION	6
4.0 COMMISSIONING	10
5.0 EXPLANATION TO USER	11
6.0 MAINTENANCE	12
7.0 FAULT FINDING	14
8.0 SPARE PARTS	15
9.0 GUARANTEE	17
10.0 ENVIRONMENTAL INFORMATION	17
11.0 COMMISSIONING RECORD	18
12.0 SERVICE RECORD	19
13.0 SPARES STOCKISTS	20

# 1.0 INTRODUCTION

Thank you for purchasing a Heatrae Sadia Streamline Undersink Vented Water Heater. The Streamline is manufactured in the UK to the highest standards and has been designed to meet all the latest relevant safety specifications.

## 1.1 IMPORTANT POINTS

The Streamline must be installed and commissioned by a competent person. Please read and understand these instructions before installing the Streamline. Following installation and commissioning, the operation of the Streamline should be explained to the user and these instructions left with them for future reference.

The Streamline is not intended for use by persons (including children) with reduced physical, sensory or mental capabilities, or lack of experience and knowledge, unless they have been given supervision or instruction concerning the use of the appliance by a person responsible for their safety.

Children should be supervised to ensure they do not play with the Streamline.

## 1.2 PACK CONTENTS

Before commencing installation check that all the following components have been supplied with your Streamline Undersink Water Heater:

- Wall Mounting Bracket
- Fixing Plugs and Screws
- Plumbing Connections (x2)
- Thermostat Knob
- Flow Restrictor

# 2.0 TECHNICAL SPECIFICATIONS

Electrical Rating	1.0kW @ 240v / 0.9kW @230v~ 3.0kW @ 240v / 2.7kW @ 230v~
Capacity	7 and 10 litres
Weight (7 Litre)	3.4Kg (empty), 10.4Kg (full)
Weight (10 Litre)	3.8Kg (empty), 13.8Kg (full)
Enclosure rated	IPX4
Operating Pressure	0 MPa (0 bar)

TABLE 01: PERFORMANCE DATA

MODEL	HEAT UP (MINUTES)	HEAT LOSS (kWhr/24hr)
7 Litre 1kW	25	0.5
7 Litre 3kW	9	0.5
10 Litre 1kW	35	0.6
10 Litre 3kW	12	0.6

FIGURE 01: IMPORTANT FEATURES

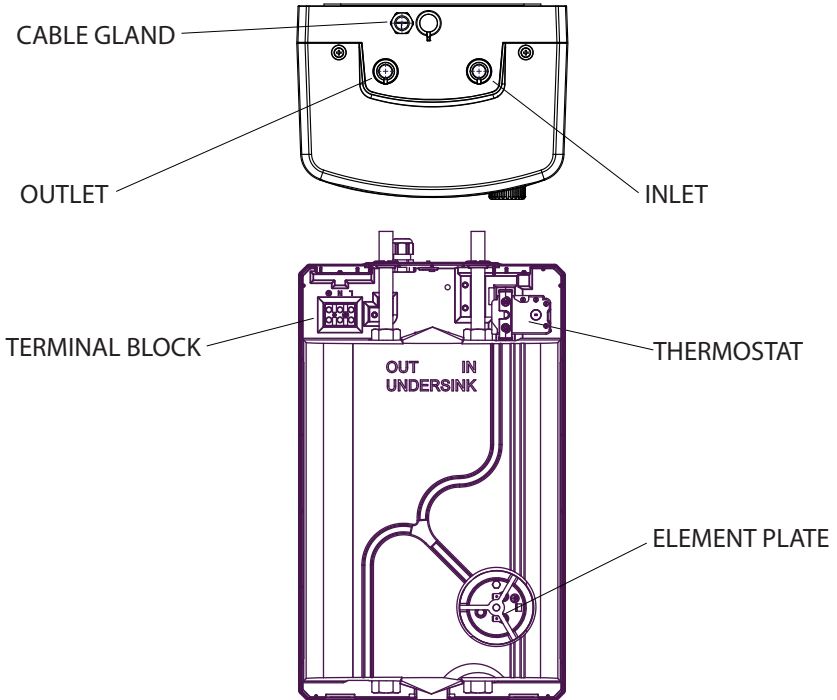
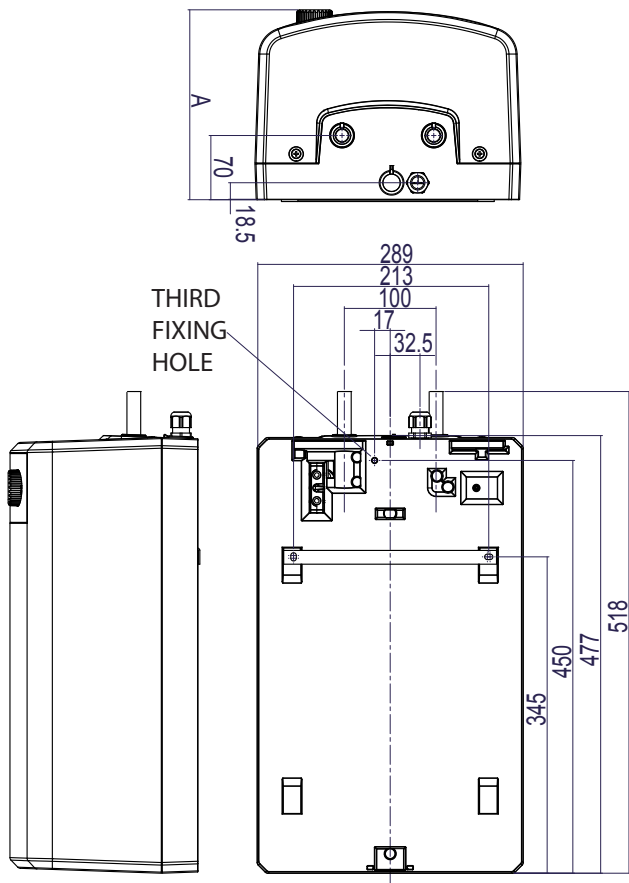

FIGURE 02: DIMENSIONS (IN mm)



DIMENSION A

7 LITRE	178
10 LITRE	278

## 3.0 INSTALLATION

**WARNING: THE STREAMLINE IS AN OPEN OUTLET WATER HEATER. THE OUTLET OF THE STREAMLINE ACTS AS A VENT AND MUST ONLY BE CONNECTED TO HEATRAE SADIA VENTED TAPS. THESE FITTINGS MUST NEVER BE BLOCKED, RESTRICTED OR MODIFIED, IN ANY WAY.**

### 3.1 GENERAL

The Streamline Undersink Water Heater must be vertically wall mounted using the wall bracket supplied. The water inlet connection must always be at the top of the Streamline Undersink Water Heater on the right hand side.

### 3.2 LOCATION AND FIXING

1. Ensure that the wall can support the full weight of the Streamline and that there are no hidden services (electricity, gas or water) below the surface of the wall.
2. DO NOT install the Streamline where it may freeze.
3. Select a suitable location for the Streamline. Allow 100mm access above and 50mm below for maintenance.

**NOTE:** National Wiring Rules may contain restrictions concerning the installation of the Streamline in bathrooms.

FIGURE 03 - FRONT COVER

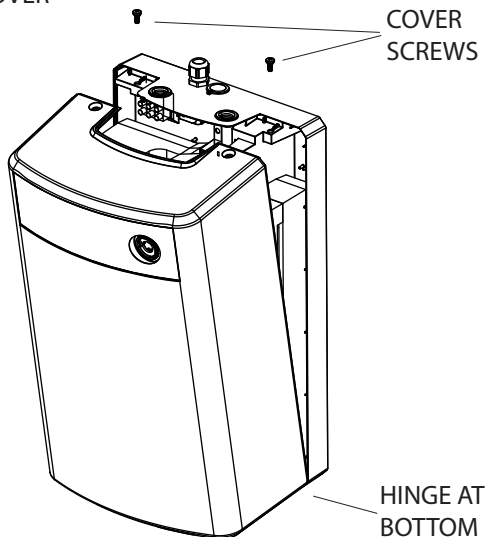

### 3.3 FIXING

1. Mark the position of the Streamline, and the position of the fixing bracket (see figure 2).
2. Fix the wall bracket using the two larger fixing plugs and screws provided.
3. Remove the cover of the Streamline by removing the two screws from the top face and rotating the cover about the bottom edge.
4. Hang the Streamline on the wall bracket, and mark the position of the fixing hole (see figure 2)
5. Remove the Streamline, drill the third fixing hole, and fit the third (smallest) fixing plug.
6. Hang the Streamline on the wall bracket again and fix securely with the third (smallest) fixing screw provided.

### 3.4 ADAPTOR PIPE ASSEMBLY

1. x2 adaptor pipes are supplied with the Streamline undersink water heater to make inlet and outlet connections.
2. Pass the pipes through the backplate and grommets (from the inside of the backplate).
3. Fit the 1/2" BSP nuts to the 1/2" BSP bosses on the inner container and tighten.
4. Ensure the grommets are reseated (snapped to the backplate).

FIGURE 04 - INLET & OUTLET PIPES

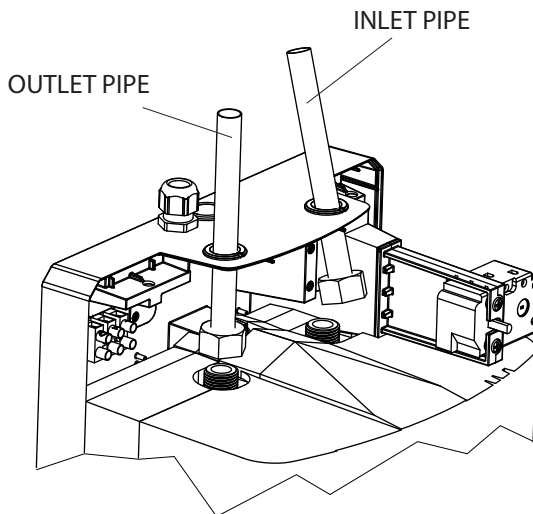

### 3.5 PLUMBING

1. Plumb the Streamline to the cold water main via a VENTED tap using 15mm diameter copper or plastic pipe. Water pressure should be no lower than 0.034MPa (0.34bar) and no higher than 1.0MPa (10bar).
2. Make connections to the adaptor pipes. The inlet is on the right, the outlet is on the left (see figure 5 below).
3. Fit the flow restrictor in the incoming supply (see figure 5 below)

NOTE: It is recommended that a WRAS listed isolating valve (not supplied) is fitted on the cold water supply to the heater for servicing.

FIGURE 05 - PLUMBING DIAGRAM

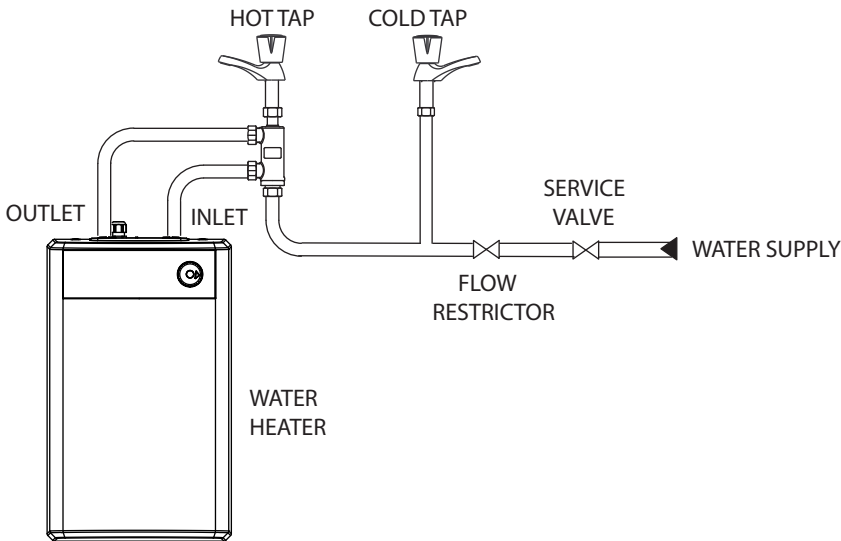
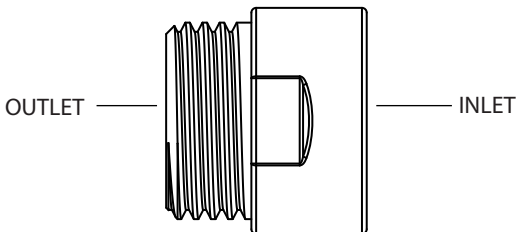

FIGURE 06 - FLOW RESTRICTOR



### 3.6 ELECTRICAL

**WARNING: THIS APPLIANCE MUST BE EARTHED. IT IS SUITABLE FOR A.C. SUPPLY ONLY.**

ELECTRICAL INSTALLATION MUST BE CARRIED OUT BY A COMPETENT ELECTRICIAN AND BE IN ACCORDANCE WITH THE LATEST I.E.E. WIRING REGULATIONS.

ENSURE THE ELECTRICAL SUPPLY IS SWITCHED OFF BEFORE MAKING ANY CONNECTIONS TO THE STREAMLINE.

1. Connect the Streamline to a 230V or 240V a.c. earthed supply only.
2. A double pole isolating switch having a contact separation of at least 3mm in each pole must be incorporated in the supply.
3. The Streamline must be fitted with a 3 core 1.5mm<sup>2</sup> flexible cable. The cable must be fitted through the cable gland and connections made to the internal terminal block as follows:  
BROWN or RED to terminal marked "L"  
BLUE or BLACK to terminal marked "N"  
GREEN/YELLOW or GREEN wire to terminal marked 

FIGURE 07 - WIRING DIAGRAM



# 4.0 COMMISSIONING

DO NOT SWITCH ON THE ELECTRICAL SUPPLY UNTIL THE STREAMLINE HAS BEEN FILLED WITH WATER AND CHECKED FOR LEAKS.

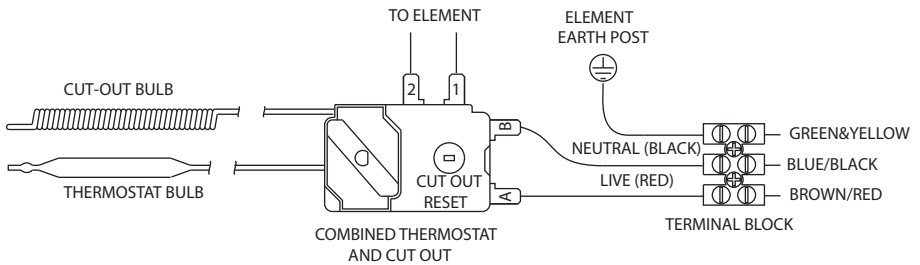
1. Check all water and electrical connections are tight.
2. Check that the thermostat and cutout capillaries are located correctly in the element pockets.
3. Switch on the water supply and open the hot tap. Leave the water flowing for a short while to flush out the pipework.
4. Close the hot tap and check the system for leaks.
5. Refit the front cover and x2 securing screws.
6. Fit the thermostat knob (see figure 8).
7. Set the temperature. The maximum setting is 70°C and the minimum is 5°C. Rotate the thermostat knob clockwise to increase the temperature, and anticlockwise to decrease the temperature . Settings above 60°C are recommended.
8. Switch the power on and check the water heats (see table 1 for heat up times).
9. Check the temperature and adjust if needed.

### NOTE:

- The thermostat can be locked in position to set the water temperature to 40°C.
- Remove the locking screw from the inside of the front cover and refit it to the outside of the front cover (see figure 8).
- Align the locking detail on the inside of the thermostat knob to the locking screw when fitting the thermostat knob in place.

FIGURE 08 - THERMOSTAT KNOB

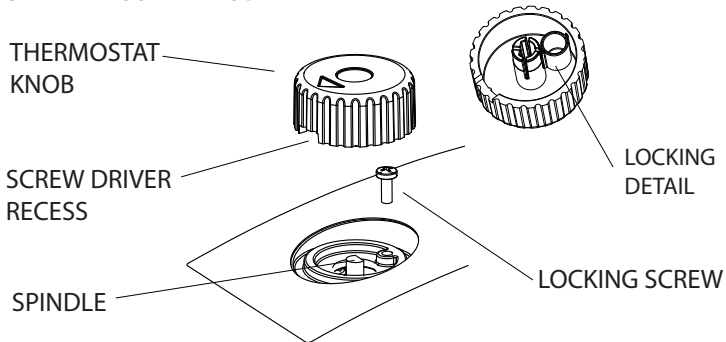

# 5.0 EXPLANATION TO USER

Following Installation and Commissioning of the water heater, the operation should be fully explained to the user.

## 5.1 HOT WATER

1. Indicate the location of the water heater and identify the outlets to which it is connected.
2. Explain how to adjust the temperature and confirm whether the temperature is locked or not.
3. Explain that the water in the Streamline will expand during heating causing the tap to drip. This is normal and is not a fault with the Streamline.

## 5.2 SYSTEM MALFUNCTION

1. Explain how to isolate electrical and water supplies in case of a fault.
2. Explain that a qualified plumber and/or electrician should be contacted if there is a fault.
3. Explain how to identify/check basic faults.

## 5.3 SYSTEM MAINTENANCE

Explain the necessity to carry out regular maintenance of the water heater to ensure its continued safe and efficient operation.

## 5.4 LITERATURE

Hand over the Fitting Instructions to the user.

# 6.0 MAINTENANCE

**WARNING: DISCONNECT FROM ALL ELECTRICAL SUPPLIES BEFORE BEGINNING ANY WORK ON THE STREAMLINE. WATER CONTAINED IN THE WATER HEATER MAY BE VERY HOT!**

To ensure the continued safe and efficient operation of the Streamline, it should be regularly maintained.

Maintenance should be carried out by a competent person and any replacement parts used should be Heatrae Sadia 'Streamline' spare parts.

Little maintenance is required, however in hard water areas the Streamline may require periodic descaling to ensure efficient operation.

## 6.1 DRAIN THE STREAMLINE

1. Ensure the water and power supplies to the Streamline are switched off and the water is cold.
2. Remove the thermostat knob (use a medium sized flat bladed screwdriver to carefully prise the thermostat knob from the front cover).
3. Remove the front cover (see section 3.3.3).
4. Disconnect the wires from the Element Plate Assembly (EPA).
5. Remove the capillary cut out and thermostat bulbs from the EPA.
6. Remove the front insulation.
7. Use a 5mm allen key to rotate the drain plug in an anti clockwise direction through 180 degrees.
8. Use a medium sized flat bladed screw driver to carefully prise the drain plug from the inner container.

FIGURE 09 - DRAIN PLUG

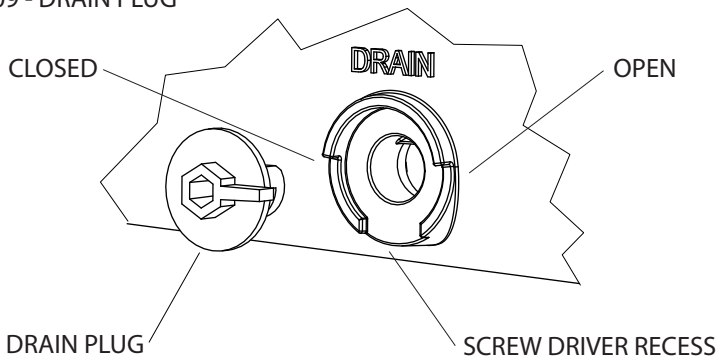

## 6.2 DESCALE THE STREAMLINE

1. Drain the Streamline (see section 6.1).
2. Undo the locknut (rotate the locknut anticlockwise until it is clear of the inner container)
3. Remove the Element Plate assembly (EPA) and gasket.
4. Remove scale from the element and the inner container.
5. Renew the gasket.
6. Refit to EPA and locknut to the inner container (ensure the EPA is aligned correctly. The element should be horizontal. A location pin is included in the EPA to ensure correct alignment).
7. Refit the locknut (rotate the locknut clockwise until the EPA is held securely in place. NOTE: When tight, one of the locknut spokes should be at '9 O' Clock' and central to the live and neutral connections).
8. Refit the drain plug (push the drain plug fully into the inner container and rotate clockwise 180 degrees using a 5mm allen key).
9. Refit the insulation.
10. Refit the wires and capillary bulbs (ensure the wires are re seated in the insulation tracks and the capillary cut out and thermostat bulbs are fully pushed home).
11. Recommission the Streamline (see section 4).

FIGURE 10 - ELEMENT PLATE ASSEMBLY

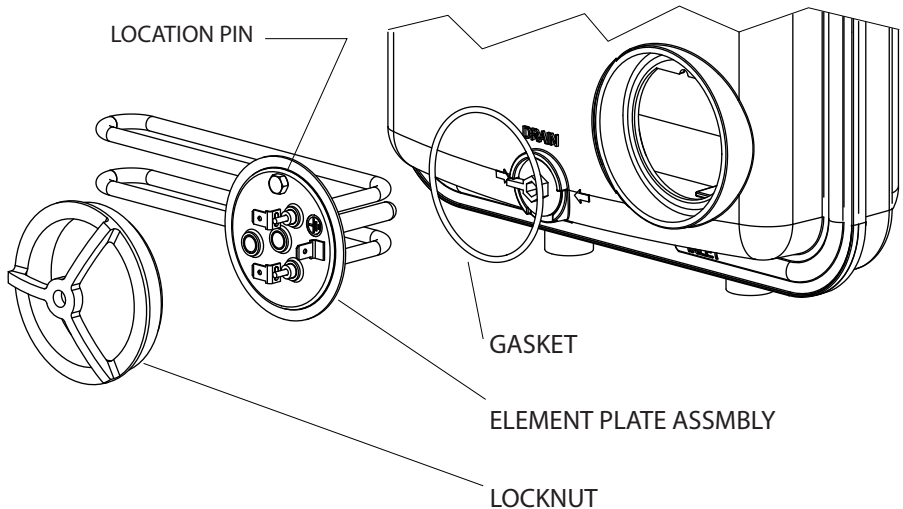

# 7.0 FAULT FINDING

WARNING: DISCONNECT FROM ALL ELECTRICAL SUPPLIES BEFORE BEGINNING ANY WORK ON THE WATER HEATER. WATER CONTAINED IN THE WATER HEATER MAY BE VERY HOT!

The Streamline should give trouble free operation, however should a problem occur, the table below should enable most faults to be identified with ease.

Fault Finding should be carried out by a competent person and any replacement parts used should be authorised Heatrae Sadia spare parts.

TABLE 02: FAULT FINDING

SYMPTOM	PROBABLE CAUSE	ACTION
No water	Mains water not turned on.	Check supply and turn on.
	Insufficient mains pressure.	Check supply.
	Blockage in tap.	Clean tap
No hot water	No water in heater.	Fill water heater.
	Cut out has operated.	Reset cut out.
	Faulty thermostat.	Replace thermostat.
	Faulty element.	Replace element.
Water is too hot	Thermostat is set too high.	Adjust thermostat.
	Faulty thermostat.	Replace thermostat.

NOTE: THE WATER IN THE STREAMLINE WILL EXPAND DURING HEATING CAUSING THE TAP TO DRIP. THIS IS NORMAL AND IS NOT A FAULT WITH THE STREAMLINE.

## 7.1 CUT OUT RESET

1. Disconnect the electrical supply.
2. Remove the front cover (see section 3).
3. Depress the red button (see figure 14).
4. Recommission the Streamline (see section 4).
5. If the cut out continues to operate contact the Heatrae Sadia Service Team.

FIGURE 11 - OVER TEMPERATURE CUT OUT

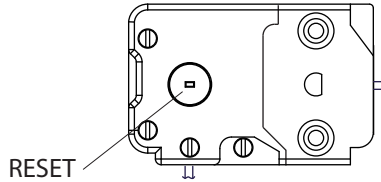

## 8.0 SPARE PARTS

The following comprehensive list of spare parts is available for your Streamline Undersink water heater.

Please refer to the Rating Label on the top face of the Streamline before ordering to ensure the correct spare part is obtained.

**DO NOT REPLACE WITH PARTS NOT RECOMMENDED BY HEATRAE SADIA. THIS WILL INVALIDATE YOUR GUARANTEE AND MAY RENDER THE INSTALLATION DANGEROUS.**

1	1kW Element Plate (with O ring)	95606917
2	3kW Element Plate (with O ring)	95606918
3	EPA O Ring (pack of 10)	95611018
4	EPA Locknut	95607617
5	7 Litre Inner Container	95608028
6	10 Litre Inner Container	95608029
7	Drain Pug (with O ring)	95608929
8	Drain Plug O Ring (pack of 10)	95611017
9	Thermostat	95612647
10	Adaptor Pipe	95607619
11	7 Litre Front Cover (Undersink)	95614302
12	10 Litre Front Cover (Undersink)	95614304
13	Thermostat Knob	95605091
14	7 Litre Insulation Set	95607330
15	10 Litre Insulation Set	95607331
16	Screw Set (pack of 10)	95607620

FIGURE 12: SPARE PARTS

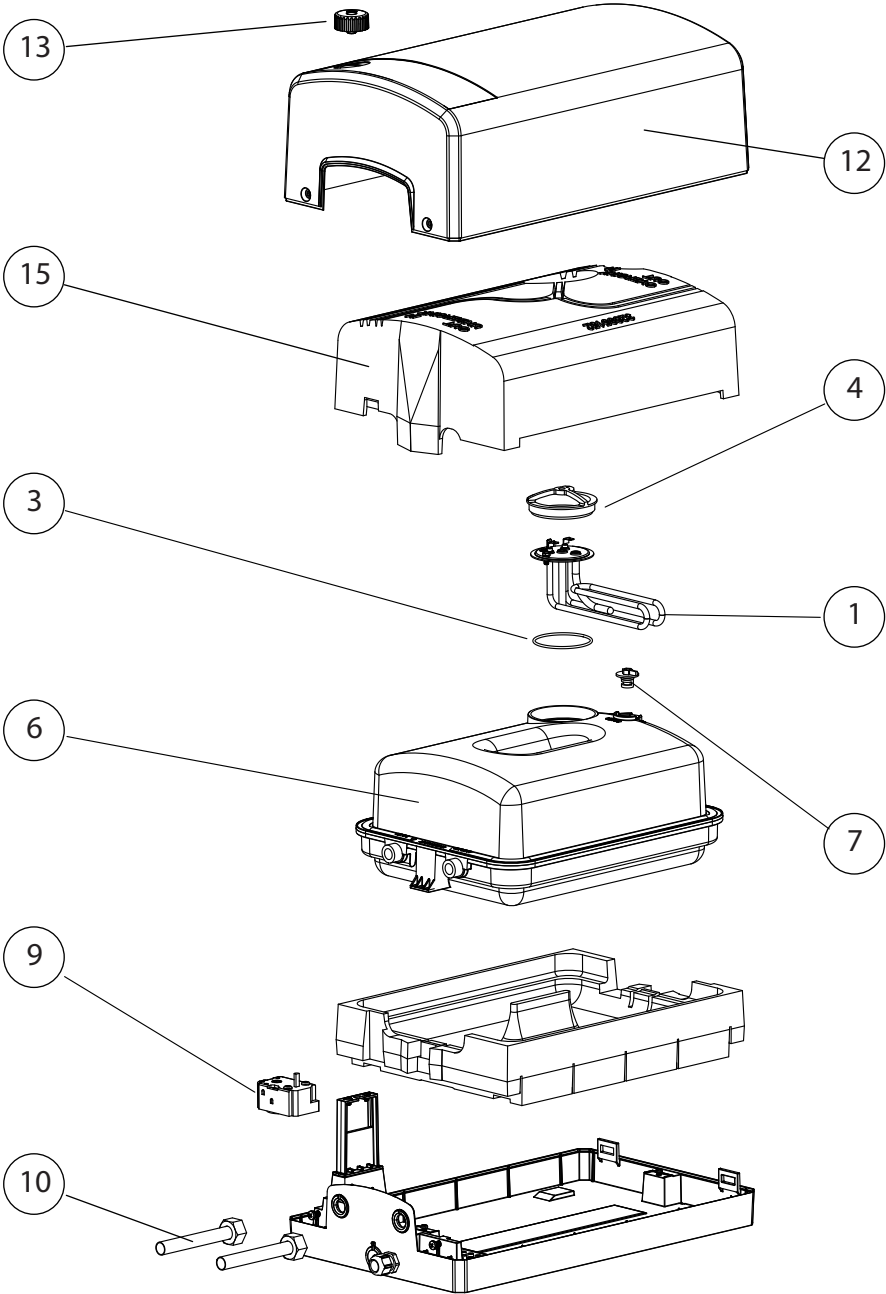

## 9.0 GUARANTEE

This Streamline water heater is guaranteed for a period of two years from the date of purchase provided:

1. The Streamline has been installed in accordance with these instructions and all necessary inlet, vent, and electrical connections have been fitted correctly.
2. Any valves or controls are of Heatrae Sadia recommended type.
3. The Streamline has not been tampered with and has been regularly maintained.
4. The Streamline has been used only for heating potable water.

The Streamline is not guaranteed against damage by frost or due to the build up of scale.

Please note that if Heatrae Sadia personnel or agents are requested to descale the Streamline, this work will be chargeable.

This guarantee does not affect the statutory rights of the consumer.

## 10.0 ENVIRONMENTAL INFORMATION

This product is manufactured from many recyclable materials. At the end of its useful life it should be disposed of at a Local Authority Recycling Centre.

# 11.0 COMMISSIONING RECORD

Installation Date: \_\_\_\_\_

Model and Serial Number: \_\_\_\_\_

Installer (Plumbing): \_\_\_\_\_

Contact Details: \_\_\_\_\_

Competency Scheme & ID Number: \_\_\_\_\_

Installer (Electrical): \_\_\_\_\_

Contact Details: \_\_\_\_\_

Competency Scheme & ID Number: \_\_\_\_\_

Comments: \_\_\_\_\_

\_\_\_\_\_  
\_\_\_\_\_

Mains supply pressure and flow rate	
Isolation valve fitted	
Flow reducer fitted	
Pipework checked for leaks	
Pipework bonded	
Electrical connections checked	
Thermostat locked	
Thermostat setting	
Water Temperature	

# 12.0 SERVICE RECORD

Service Date: \_\_\_\_\_  
Engineer: \_\_\_\_\_  
Contact Details: \_\_\_\_\_  
Competency Scheme & ID Number: \_\_\_\_\_  
Comments: \_\_\_\_\_  
\_\_\_\_\_  
\_\_\_\_\_

Service Date: \_\_\_\_\_  
Engineer: \_\_\_\_\_  
Contact Details: \_\_\_\_\_  
Competency Scheme & ID Number: \_\_\_\_\_  
Comments: \_\_\_\_\_  
\_\_\_\_\_  
\_\_\_\_\_

Service Date: \_\_\_\_\_  
Engineer: \_\_\_\_\_  
Contact Details: \_\_\_\_\_  
Competency Scheme & ID Number: \_\_\_\_\_  
Comments: \_\_\_\_\_  
\_\_\_\_\_  
\_\_\_\_\_

Service Date: \_\_\_\_\_  
Engineer: \_\_\_\_\_  
Contact Details: \_\_\_\_\_  
Competency Scheme & ID Number: \_\_\_\_\_  
Comments: \_\_\_\_\_  
\_\_\_\_\_  
\_\_\_\_\_

# 13.0 SPARES STOCKISTS

For the fast and efficient supply of spares please contact the stockists listed below.

Advanced Water Company Ltd.  
Unit D5 Enterprise way  
Vale park, Evesham  
Worcs, WR11 1GS  
Tel: 01386 760066  
Fax: 01386 760077

Electric Water Heating Co.  
2 Horsecroft Place, Pinnacles  
Harlow, Essex, CM19 5BT  
Tel: 0845 0553811  
E-Mail: [sales@ewh.co.uk](mailto:sales@ewh.co.uk)

SPD  
Units 9 & 10 Hexagon Business Centre  
Springfield Road, Hayes  
Middlesex, UB40 0TY  
Tel: 020 8606 3567

Parts Center  
Tel: 0845 2709800  
[www.partscenter.co.uk](http://www.partscenter.co.uk)

Newey & Eyre  
Specialist Products Division  
Please contact your local branch

UK Spares Ltd.  
Tower Lane, Warmley  
Bristol, BS30 8XT  
Tel: 0117 961 6670

William Wilson Ltd.  
Unit 3A, 780 South Street  
Whiteinch, Glasgow, G14 OSY  
Tel: 0141 434 1530

---

## HEATRAE SADIA

The quality name in water heating

Heatrae Sadia Heating  
Hurricane Way Norwich NR6 6EA

[www.heatraesadia.com](http://www.heatraesadia.com)

PART OF BDR THERMEA

Service: 0844 8711535  
Service Fax: 0844 8711528  
E-mail: [heatraesadiaservice@heateam.co.uk](mailto:heatraesadiaservice@heateam.co.uk)

36006098 issue 01