

HEATRAESADIA

SMARTER | CLEANER | WARMER

Aquatap (Boil only) Installation and user manual

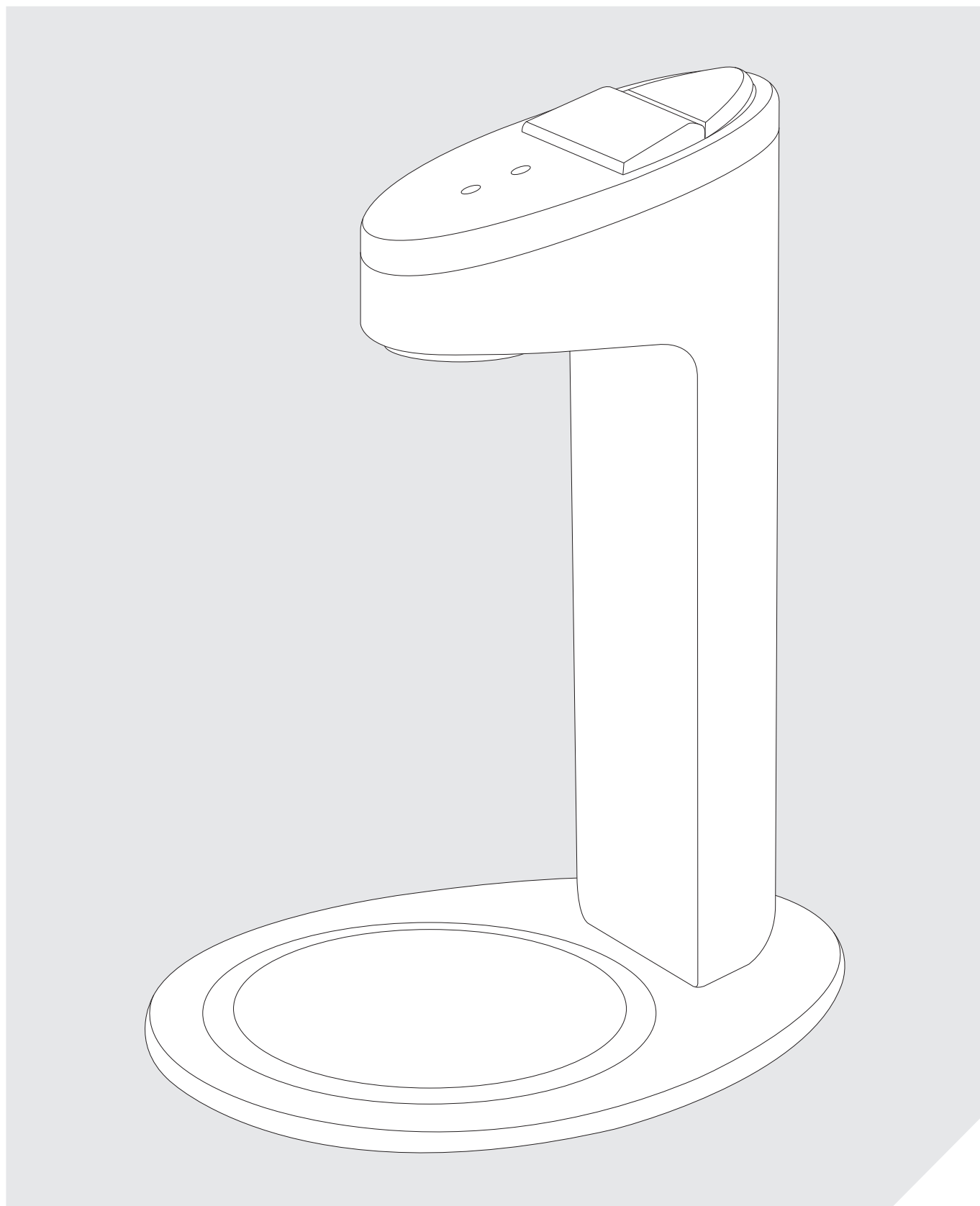

CONTENTS

SECTION	PAGE
1.0 INTRODUCTION	3
2.0 TECHNICAL SPECIFICATION	4
3.0 INSTALLATION - IMPORTANT INSTALLATION POINTS	7
4.0 INSTALLATION - MOUNTING THE WATER HEATING UNIT	8
5.0 INSTALLATION - WATER SUPPLY	9
6.0 INSTALLATION - VENT PIPE	10
7.0 INSTALLATION - DISPENSING TAP MOUNTING	10
8.0 INSTALLATION - DISPENSING TAP CONNECTION	12
9.0 INSTALLATION - ELECTRICAL REQUIREMENTS	14
10.0 COMMISSIONING	14
11.0 USER INSTRUCTIONS	17
12.0 MAINTENANCE	18
13.0 FAULT FINDING	20
14.0 SPARE PARTS	22
GUARANTEE	27
ENVIRONMENTAL INFORMATION	27
15.0 COMMISSIONING RECORD	28
16.0 SERVICE RECORD	29
17.0 SPARES STOCKISTS	32

BOILING WATER MODEL

1.0 INTRODUCTION

Thank you for purchasing a Heatrae Sadia Aquatap unit. This unit is manufactured to the highest standards and has been designed to meet all the latest relevant constructional and safety specifications.

The Aquatap unit must be installed (see sections 3.0, page 7 to 9.0, page 14), commissioned (see section 10.0, page 14) and maintained (see section 12.0, page 18) by a competent person. Please read and understand these instructions prior to installing your Aquatap unit. Following installation and commissioning of the unit, the operation of the Aquatap should be explained and demonstrated to the user. Instructions for use are explained in section 11.0, page 17. These instructions should be left with the user for future reference.

This appliance can be used by children aged from 8 years and above and persons with reduced physical, sensory or mental capabilities or lack of experience and knowledge, if they have been given supervision or instruction concerning use of the appliance in a safe way and understand the hazards involved. Children shall not play with the appliance. Cleaning and user maintenance shall not be made by children without supervision.

Intelliboil™Plus is a patented control system for managing the efficiency of the Aquatap's boiling cycle. It regularly brings the contents of the water container to boil in response to ongoing user demand. However, when there has been no draw off for a period of one hour, *Intelliboil™Plus* steps back the stored water temperature. This avoids unnecessary boiling - possibly for a number of hours or even days - until there is renewed user demand. When this occurs, the boiling cycle resumes.

The appliance is intended to be used in commercial applications such as (but not limited to):

- Hotel conference suites
- Waiting rooms
- Staffroom kitchens/rest rooms

COMPONENT CHECKLIST

Before commencing installation please check that all the following components have been supplied in the packaging:

- Aquatap dispensing tap
- Aquatap water heating unit
- 2 x 0.5m hose
- 4 x hose clamps

2.0 TECHNICAL SPECIFICATION

AQUATAP HEATER

Model reference	95200261
Electrical rating	2.3kW @ 230 V ~ 2.5kW @ 240 V ~
Nominal capacity	5.0 litres
Weight (full)	17.5kg
Rated pressure	0 MPa (0 bar)
Minimum supply pressure	0.05 MPa (0.5 bar)
Maximum supply pressure	1.0 MPa (10 bar)
Enclosure rating	IPX2

Nominal commissioning time (minutes) to temperature ready 24

FIGURE 1 : AQUATAP HEATER

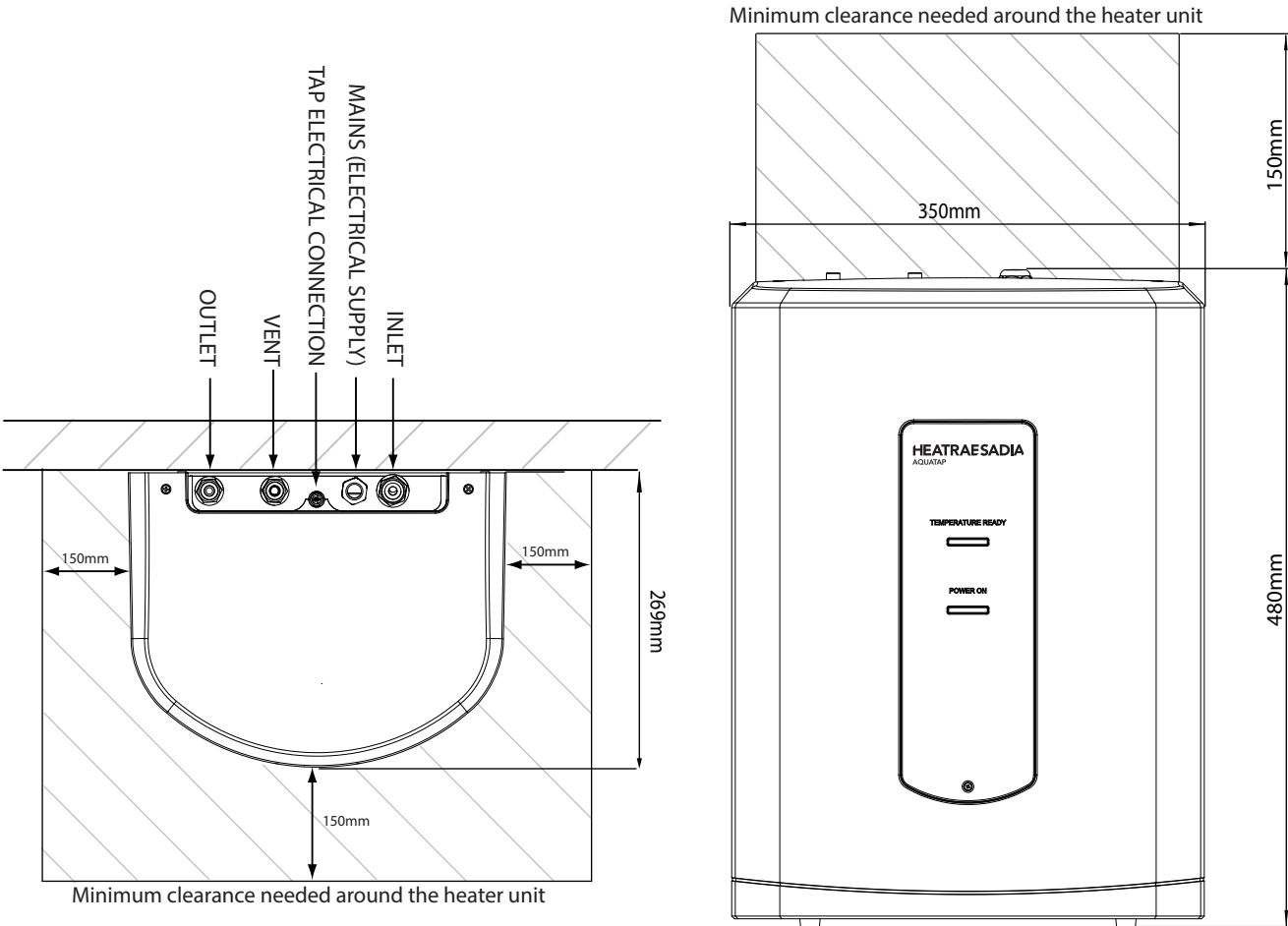

FIGURE 2: AQUATAP HEATER - IMPORTANT FEATURES

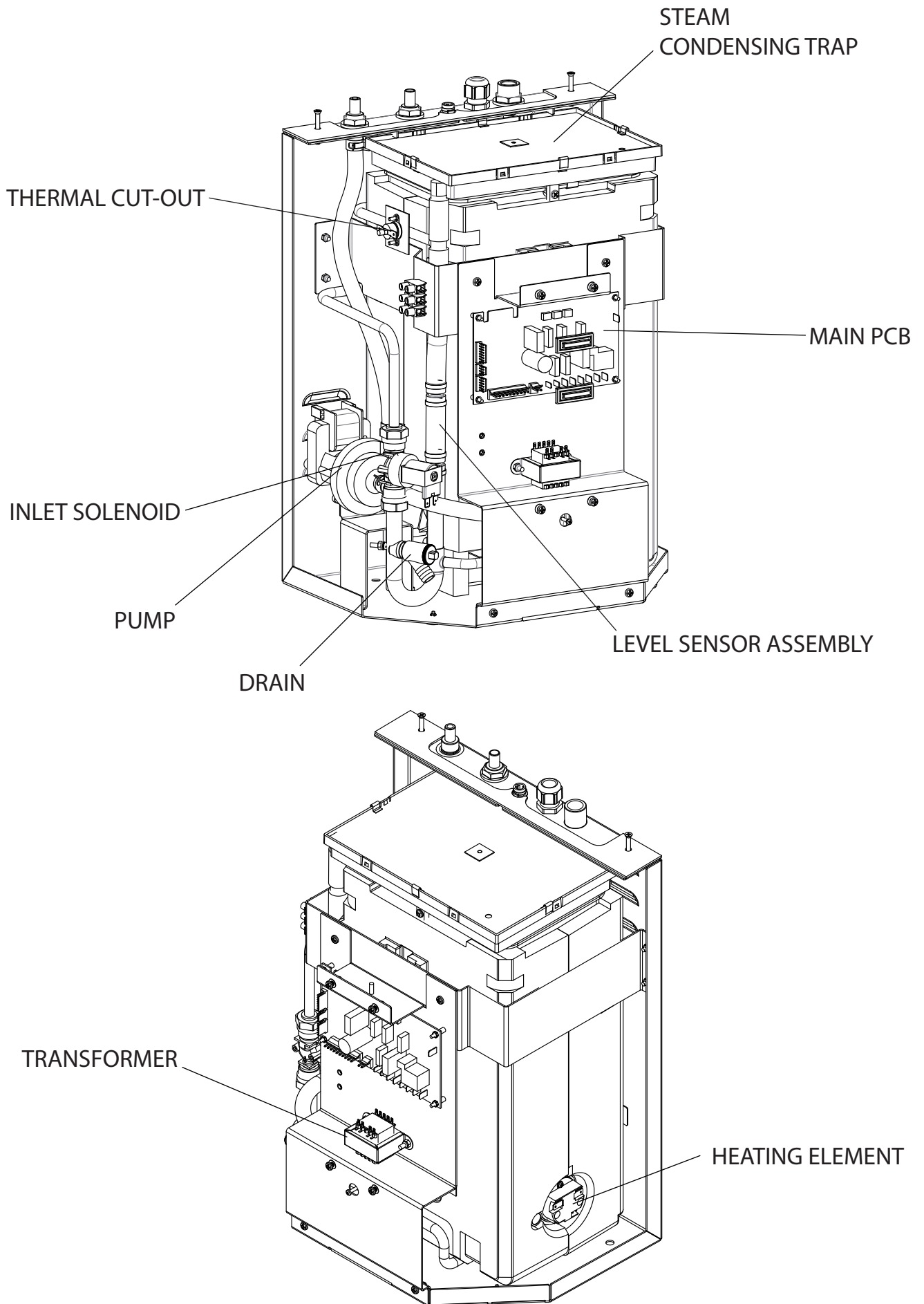
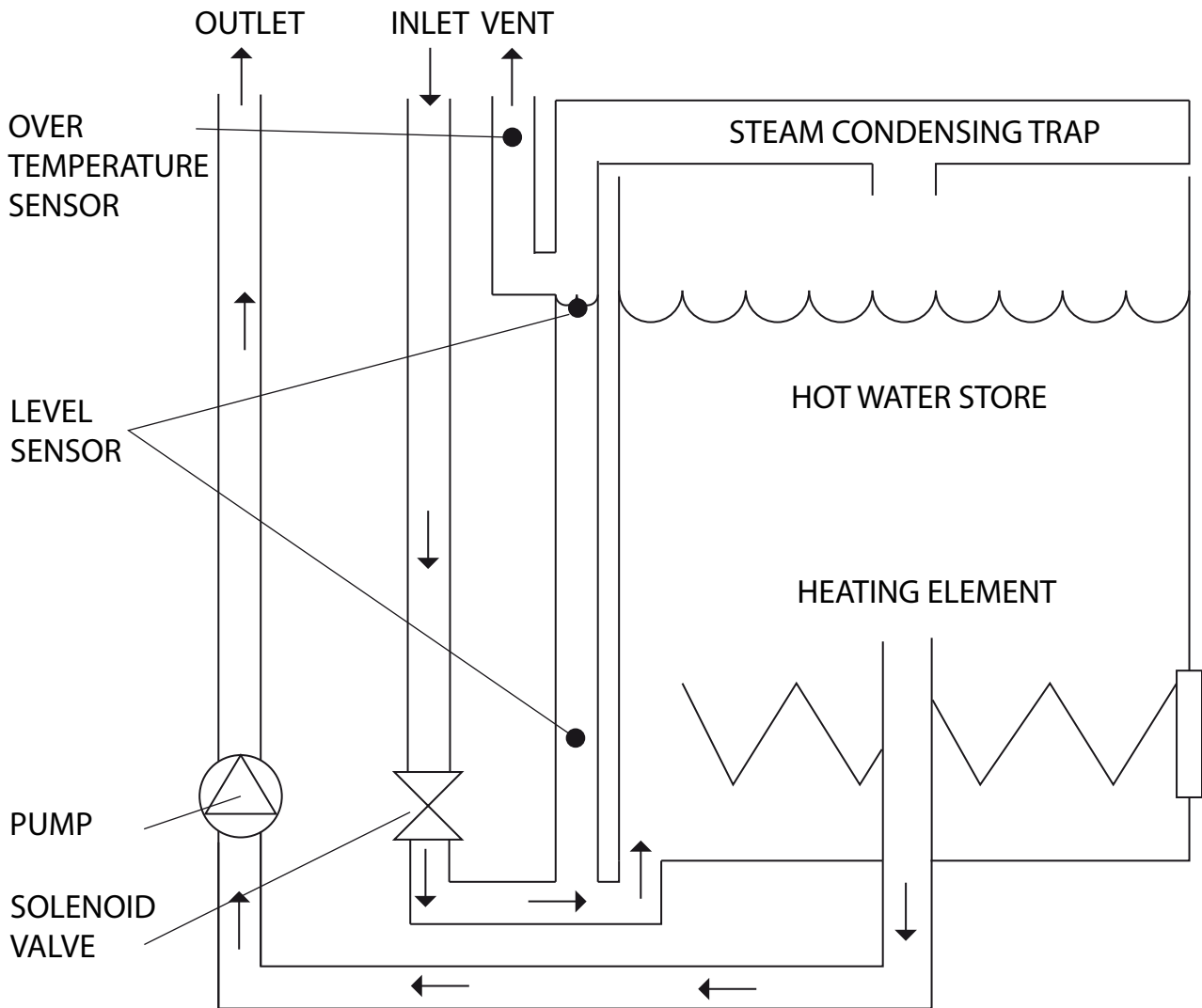

FIGURE 3: AQUATAP WATER HEATER SCHEMATIC



3.0 IMPORTANT INSTALLATION POINTS

- 3.1 The Aquatap unit must be installed in accordance with the relevant requirements of:
- The appropriate building regulations by application of either The Building Regulations (England and Wales), The Building Regulations (Scotland) or The Building Regulations (Northern Ireland). In territories other than those listed the local regulations in force must be complied with.
 - The Water Supply (Water Fittings) Regulations (England, Wales and Northern Ireland) or The Water Byelaws in Scotland.
- 3.2 The Aquatap stores and dispenses water at or close to boiling point whilst switched on. Due caution must be taken when choosing a location for the product to minimise any possible misuse. The dispenser tap should be located so that it discharges over a sink or mounted on its own purpose designed drip tray (available as an accessory, product code 95970138).
- 3.3 The Aquatap is a vented water heater. The vent pipe must never be blocked, obstructed or removed. **Warning: In the event of a unit malfunction, steam may vent from the vent pipe for a short period of time** (see fig. 5, page 11 for position of vent pipe).
- 3.4 Wherever possible the Aquatap should be supplied directly from the cold mains supply. If fed from a cold water feed cistern, the cistern must comply with the Water Regulations Guide (Clause R27.2). It should be noted that water quality may be reduced when supplied from a cistern and additional pre-treatment of the water supply to the Aquatap (eg. filtration) may be necessary.
- NOTE: In order to meet the minimum supply pressure requirements of the Aquatap, any cold feed cistern must be a minimum of 5 metres above the unit.**
- 3.5 In hard water areas, heated water will produce limescale which will be deposited in the heater. If this is not regularly removed it will impair the operation of the Aquatap unit. Where rapid and excessive scale build up is likely to occur the use of a proprietary scale reducing device on the water supply to the unit may be beneficial.
- 3.6 The Aquatap unit will adjust for ambient air temperatures of between 1°C and 40°C
- 3.7 The unit must not be installed where it is liable to freeze. If the unit is thought to be frozen it must not be switched on. It should be allowed to thaw and must then be thoroughly inspected to ensure it is undamaged.
- 3.8 The unit is not suitable for installation in an area where a water jet could be used.

4.0 INSTALLATION – MOUNTING THE WATER HEATING UNIT

- 4.1 The Aquatap water heating unit is free standing and must be mounted on a level surface. If being mounted in a cupboard, on a shelf or false base, ensure that the supporting surface can carry the full weight of the unit (see TECHNICAL SPECIFICATIONS section 2.0, page 4)
- 4.2 Refer to fig 1, page 4 for dimension details of the Aquatap water heating unit and the relative positions of the water and electrical connections.
- 4.3 The Aquatap heater unit must be located beneath the dispensing tap. It must be possible to connect the flexible hoses and electrical connection cable from the dispensing tap to the OUTLET and VENT connections on the Aquatap unit. The pipes must not be lengthened. The dispenser tap can be positioned so it discharges into a sink or mounted on its own purposed designed drip tray (available as an accessory, product code 95970138).
- 4.4 Sufficient room should be left around the unit to allow access for maintenance and servicing (see fig. 1, page 4). Two of the case fixing screws are located on the top rear edge of the unit, it must be ensured that these can be accessed in order to facilitate removal of the front cover for maintenance and servicing. An ambient temperature between 5°C and 35°C is required in the cupboard housing the Aquatap water heating unit. Air circulation must be provided so air can flow through the cupboard (see diagram below). If adequate air circulation is not provided this will cause calibration problems and the Aquatap water heating unit will not function correctly.
- 4.5 The Aquatap water heating unit is supplied with a fitted 1.5 metre electrical supply cable. It is recommended that this is connected to a fused double pole isolating switch within this distance. If the cable needs to be lengthened this must be completed by a qualified electrician. Refer to section 9.0, page 14 INSTALLATION – ELECTRICAL REQUIREMENTS for full details of the electrical installation.

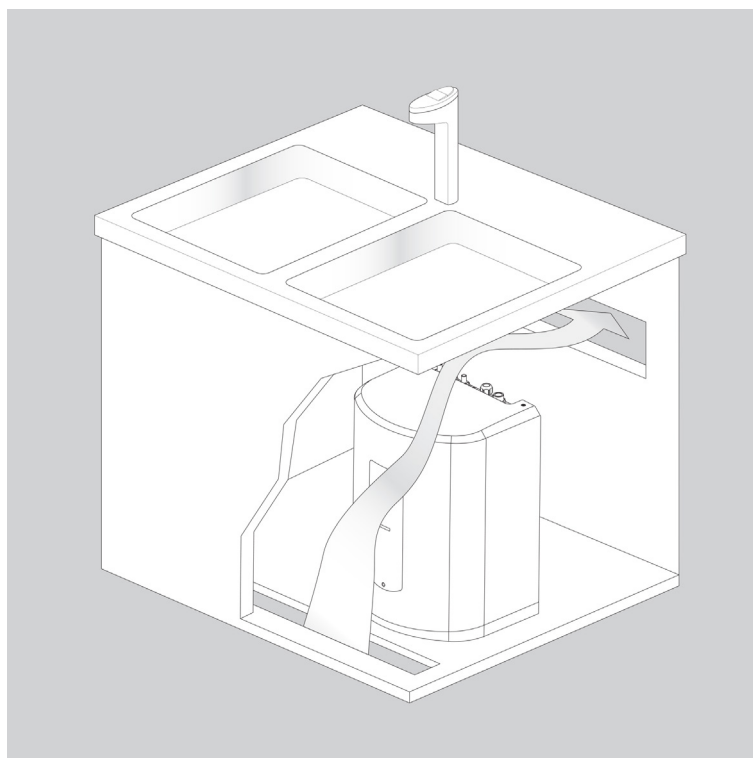

5.0 INSTALLATION - WATER SUPPLY

- 5.1 The INLET connection to the Aquatap water heating unit is located on the top rear of the unit (see fig. 1, page 4). It is threaded ½” BSP male parallel flat faced fitting. Any connection must use a suitable WRAS listed sealing washer. It is not possible to make a compression connection directly to the INLET connection.
- 5.2 A WRAS listed isolating valve must be fitted in the cold water supply to the unit to facilitate servicing the heater, ensure the water supply is clean, any debris/contamination will effect the taste of the boiling water.
- 5.3 If using hard piping ensure this is not routed where it may impair access to the case fixing screws or prevent access and/or removal of parts for servicing or maintenance.
- 5.4 The use of a WRAS listed flexible braided hose assembly is recommended for the final connection to the heater to allow for easy access/removal should it be required.
- 5.5 The hot OUTLET connection from the Aquatap water heating unit is located on the top rear of the unit (see fig. 1, page 4). It is a hose spigot to which the flexible hot supply hose to the dispensing tap is attached. Refer to section 8.0 INSTALLATION – DISPENSING TAP CONNECTION, page 12 for full details of how to mount and connect the dispensing tap to the water heating unit.

FIGURE 4: PLUMBING DIAGRAM

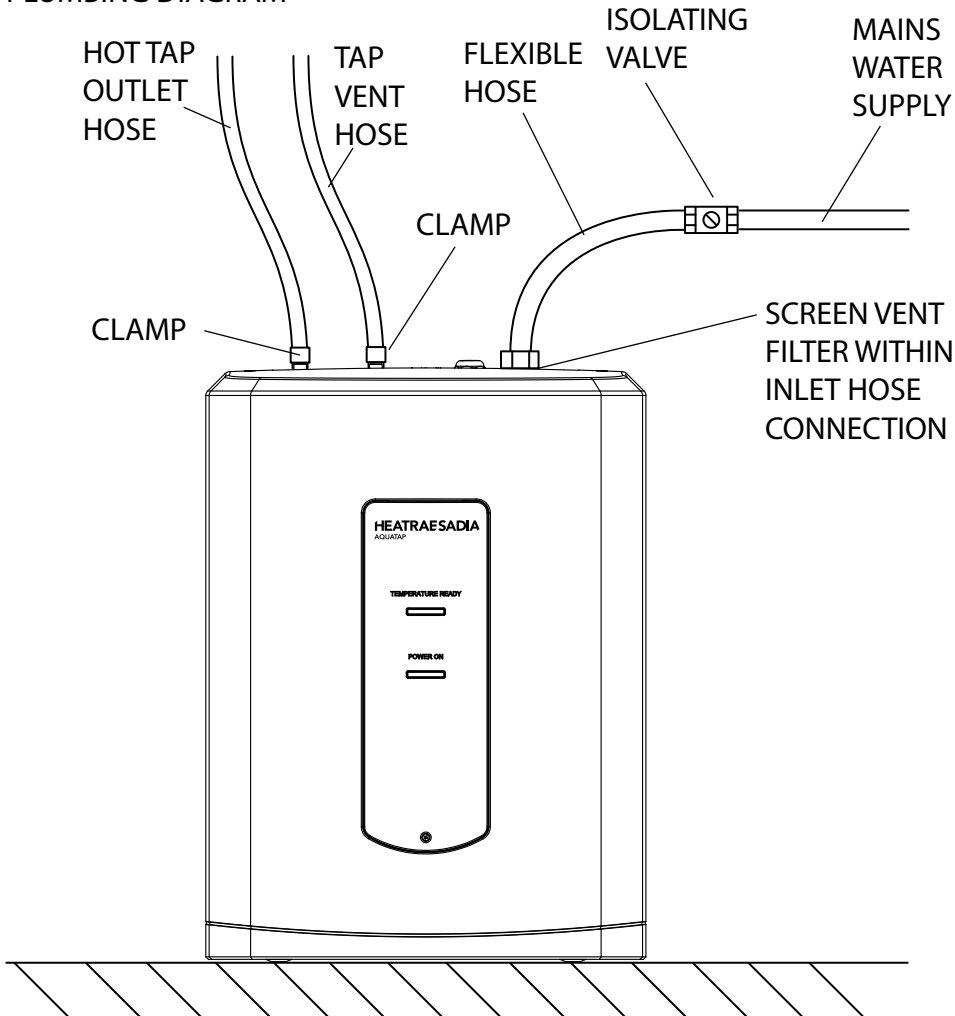

6.0 INSTALLATION – VENT PIPE

- 6.1 The VENT connection from the Aquatap water heating unit is located on the top rear of the unit (see fig. 1, page 4). It is a hose spigot to which the flexible VENT hose of the dispensing tap is attached. Refer to section 7.0 installation dispensing tap mounting below for full details of how to mount and connect the dispensing tap to the water heating unit.
- 6.2 The VENT will ensure that any excess steam or pressure is safely vented to the atmosphere in the event of a fault with the unit. **IT MUST NOT BE BLOCKED, OBSTRUCTED, DISCONNECTED OR REMOVED.**

7.0 INSTALLATION – DISPENSING TAP MOUNTING

- 7.1 The dispensing tap supplied is suitable for mounting onto a worktop or counter surface. It should be positioned such that it discharges into a sink or drip tray (fig. 6, page 11 for tap dimensions). A purpose designed drip tray is available as an accessory (order product code 95970138). If this is used, then the instructions supplied with the drip tray accessory should be followed.
- 7.2 Cut a 35mm diameter hole in the position selected through the worktop or counter surface or use the template provided if using the drip tray. **NOTE: Do not mount the dispenser directly onto a stainless steel sink.**
- 7.3 Screw the 6mm x 60mm stud into the base of the dispensing tap and connect the flexible hoses to the dispenser tap with the clips provided.
- 7.4 Ensure the sealing washer provided is correctly located on the base of the tap. A light application of clear silicon sealant on the base of the tap and the sealing washer will help ensure a watertight fit between the tap base and the worktop.
- 7.5 Feed the flexible hoses and dispenser control cable through the hole in the worktop from the top and position the tap base onto the worktop.
- 7.6 From the underside of the worktop fit the “C” clamp over the threaded securing post and slide up so it sits against the underside of the worktop. The “arms” of the “C” clamp should enclose the two flexible hoses.
- 7.7 Thread the securing nut onto the securing post and finger tighten onto the “C” clamp. If necessary adjust the position of the dispenser tap and then tighten the securing nut.
- 7.8 Make sure all pipe work is bonded and the earthing clamps conform to BS 951 and contain a label which states “SAFETY ELECTRICAL CONNECTION - DO NOT REMOVE”.
- 7.9 If required because of space issues cut the pipes (at the base of the tap) to an appropriate length making sure that they are free from burrs and clean.

FIGURE 5 : TAP MOUNTING

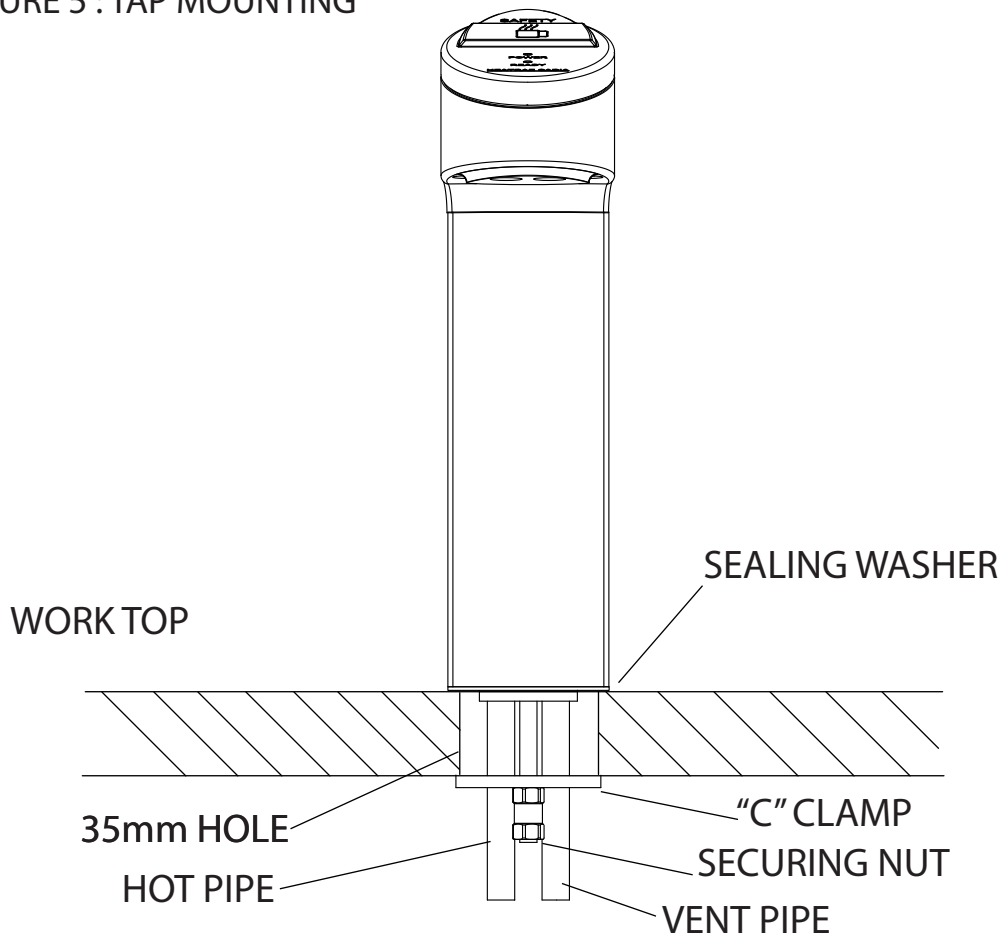
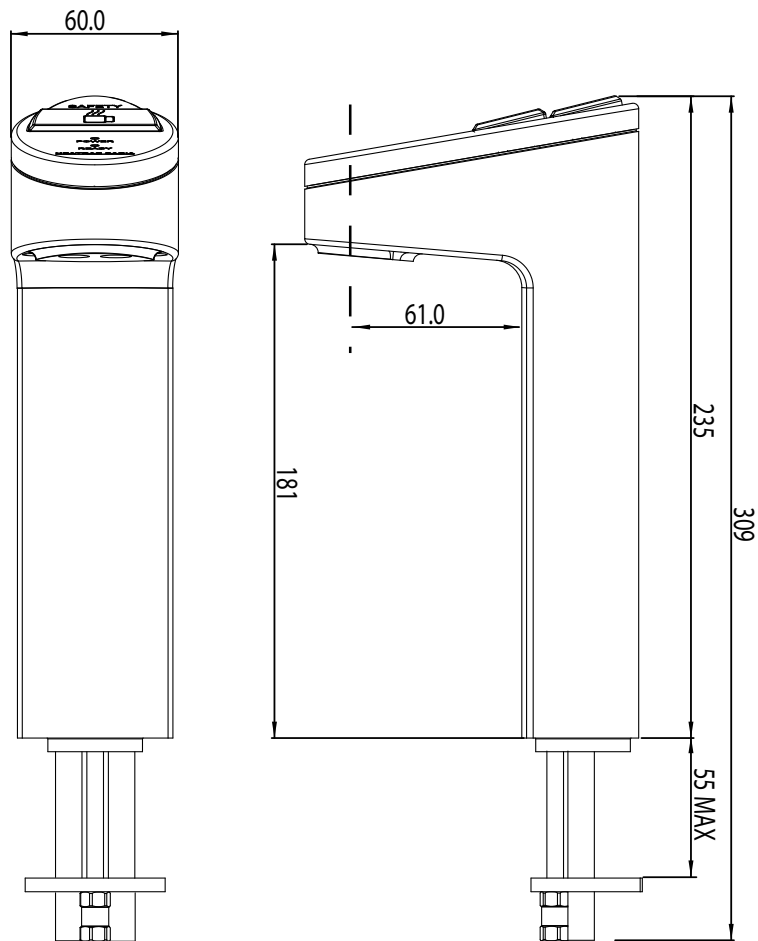

FIGURE 6 : DISPENSER DIMENSIONS



8.0 INSTALLATION – DISPENSING TAP CONNECTION

- 8.1 The hot supply hose should be connected to the OUTLET hose spigot of the Aquatap water heating unit. The hose should rise continuously from the heater to the tap without kinks or twists. If necessary it can be cut to a shorter length, but it should never be lengthened. The hose should be secured in place on the spigot using the clips provided. **Warning: Only use the hose supplied with the unit or a temperature rated WRAS approved hose.** Spare hose and clips can be ordered, part number 95 607 364.
- 8.2 The VENT hose should be connected to the VENT hose spigot of the Aquatap water heating unit. The hose should rise continuously from the heater to the tap without kinks or twists. If necessary it can be cut to a shorter length, but it should never be lengthened. The hose should be secured in place on the spigot using the clips provided.

FIGURE 7 : TAP MOUNTING (BOIL ONLY)
(NOTE: DRIP TRAY/SINK NOT SHOWN FOR CLARITY)

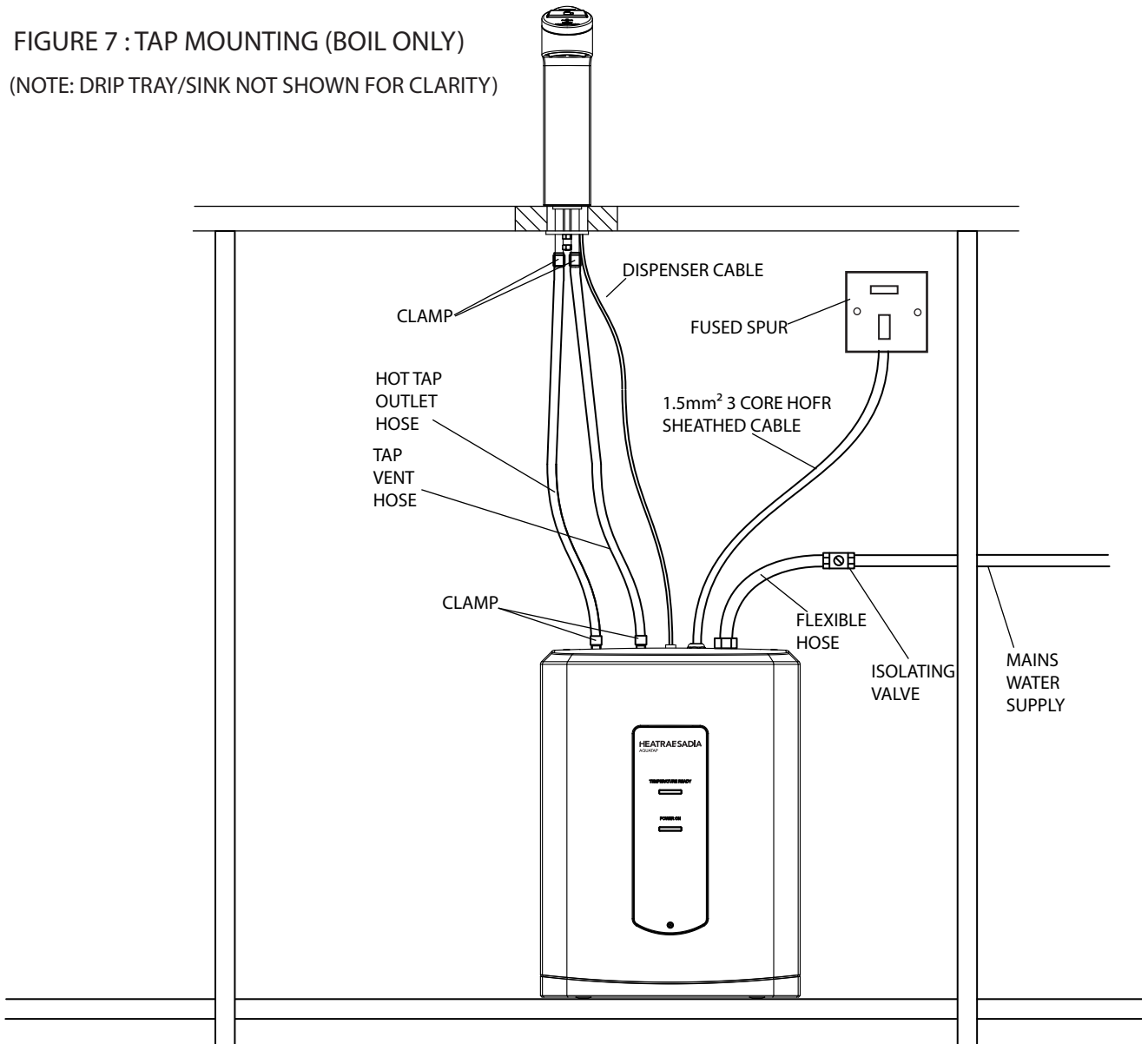
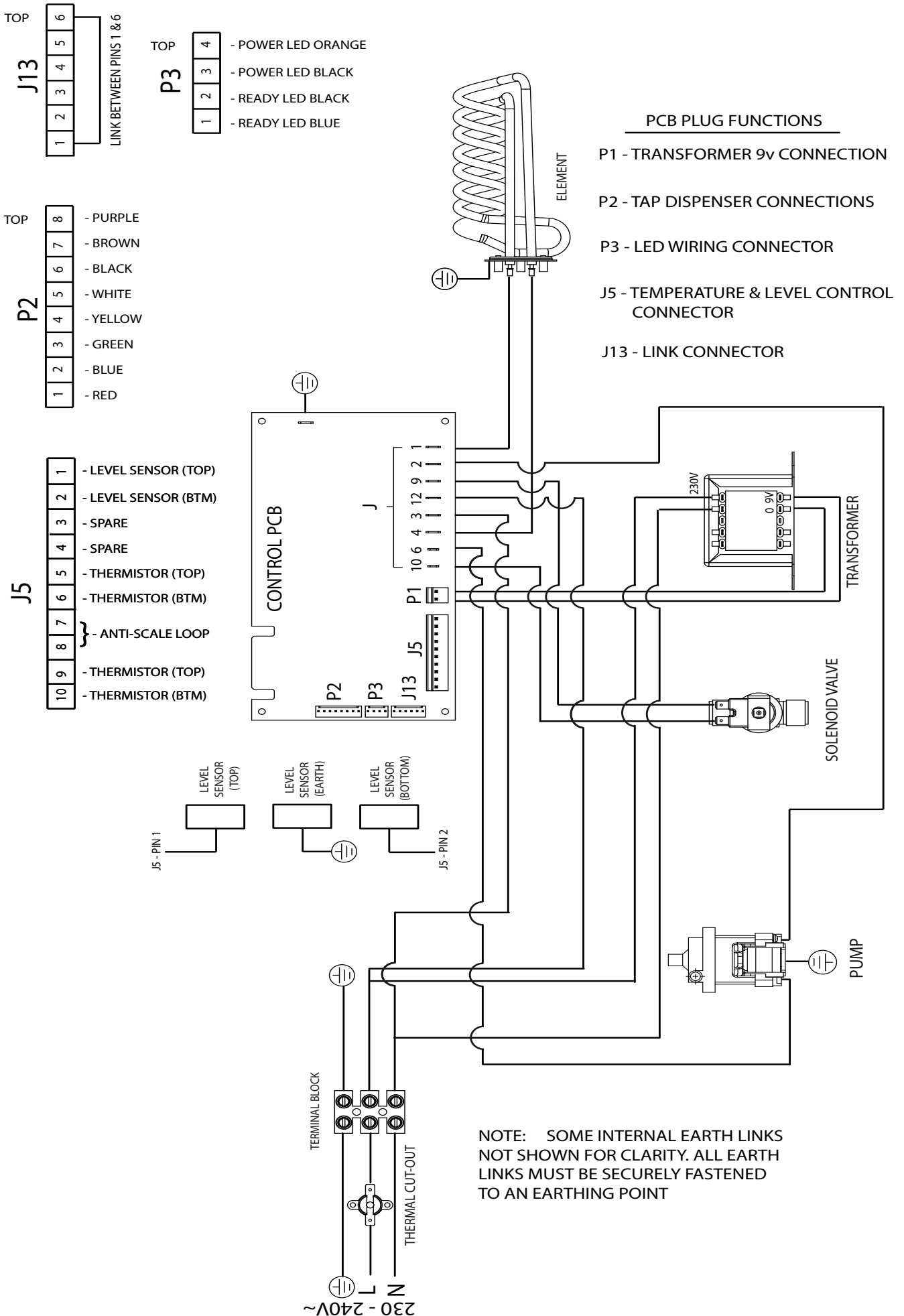

FIGURE 8: WIRING DIAGRAM



9.0 INSTALLATION – ELECTRICAL REQUIREMENTS

- 9.1 **Warning: This appliance must be earthed. It is suitable for 230/240V~ supply only.**
- 9.2 Installation must be carried out by a competent electrician in accordance with the latest edition of BS 7671 (the IEE Wiring Regulations).
- 9.3 The Aquatap water heating unit is supplied fitted with a 1.5 metre electrical supply cable. If the cable needs to be lengthened this must be completed by a qualified electrician using 3 core cable with a minimum conductor cross sectional area of 1.5 mm². The electrical supply cable must be connected to the electrical supply via a double pole isolating switch with a contact separation of at least 3mm in both poles. The electrical supply should be fused 13 amp.
- 9.4 The Aquatap dispensing tap must be connected to the water heating unit by means of the black sheathed control cable. The cables from each unit are terminated in a mating plug and socket which should be pushed firmly together to connect them.
- 9.5 A schematic wiring diagram of the Aquatap installation is shown in fig. 8, page 13.
- 9.6 If the Aquatap heater is to be unused for significant periods of time, running costs can be reduced by switching the unit off. It is recommended that this is done automatically by incorporating a suitable time switch in the electrical supply to the unit. A suitable time switch is available as an accessory (order product code 95970124) which can be set to switch the unit on for a suitable period of time to allow it to reheat before it is next used. **NOTE: If selecting an alternative time switch it must be capable of switching a 13 amp resistive load.**

10.0 COMMISSIONING

- 10.1 The Aquatap heater incorporates an electronic controls system which has a self commissioning and calibration function. No installer or user adjustment is necessary before use.
- 10.2 Check that all electrical, water and vent pipe connections have been correctly made and are secure.
- 10.3 To remove the main cover, unscrew the fascia securing screw and remove the fascia, remove two top cover securing screws and four cover securing screws. The cover can now be pulled back from the heater assembly. Caution should be taken here as the two LED's are attached to the main cover. Pull the cover back to allow enough access to the LED wires and slide the LED's from the slots in the cover to allow main cover removal. Refit the cover in reverse sequence. When replacing the two LED wires, make sure the LED with the orange wire is at the top and the LED with the blue wire is at the bottom.
- 10.4 If the cover has been removed, this should be replaced and secured with the supplied fixing screws (see fig. 9, page 15). Turn on the water and electrical supplies to the Aquatap heater.
- 10.5 Once commissioned it is advisable to insulate both hot and cold hoses.

FIGURE 9 : FRONT COVER REMOVAL

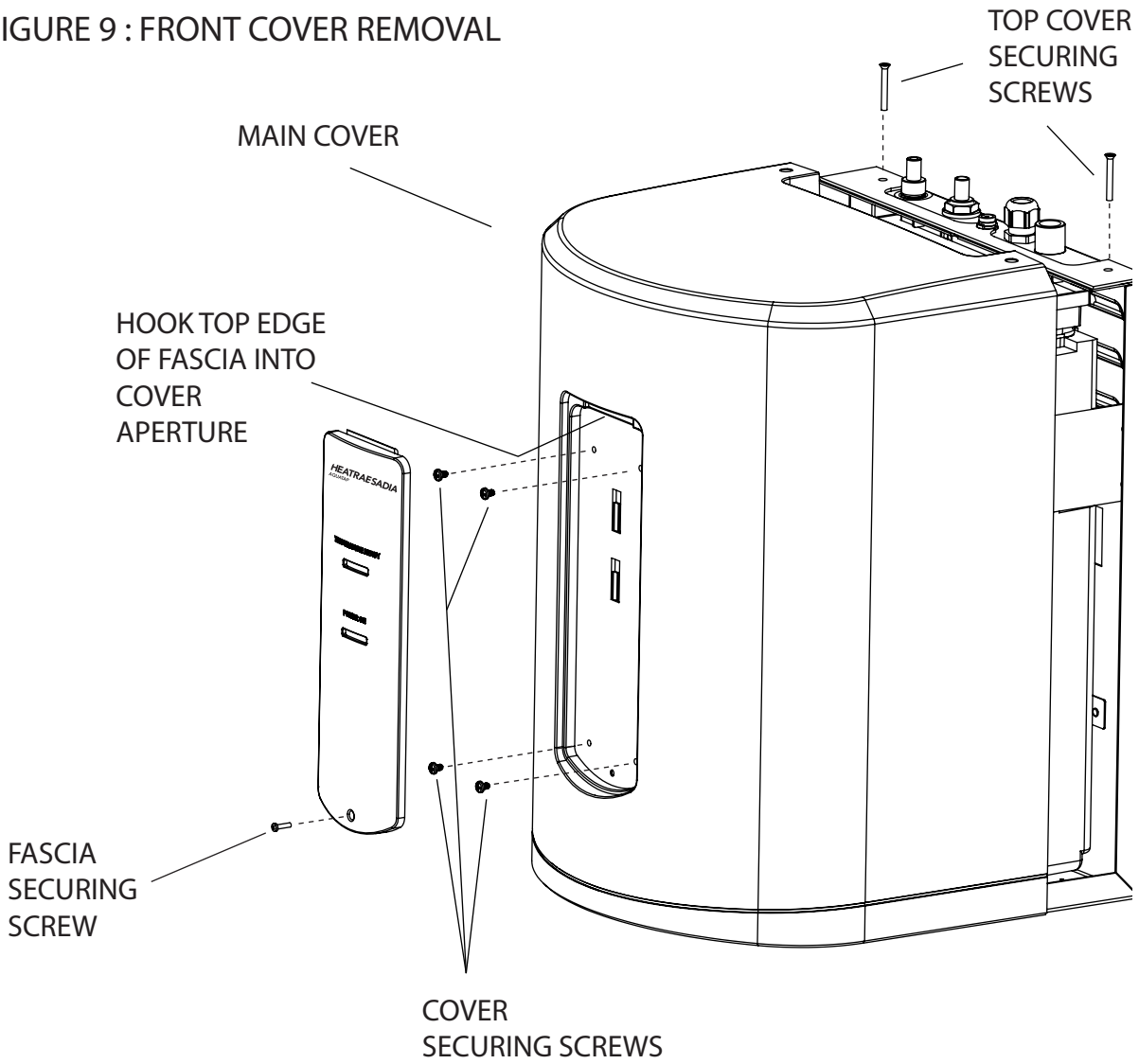

10.6 The “TEMPERATURE READY” indicator light on the Aquatap heater unit and the “READY” LED on the dispenser tap will flash intermittently. This indicates that the unit is in the self commissioning mode. Whilst in this mode the water will not be hot enough for use. **DO NOT DRAW ANY WATER OFF DURING THE SELF-COMMISSIONING MODE.**

FIGURE 10 : LED POSITIONS (DISPENSER)

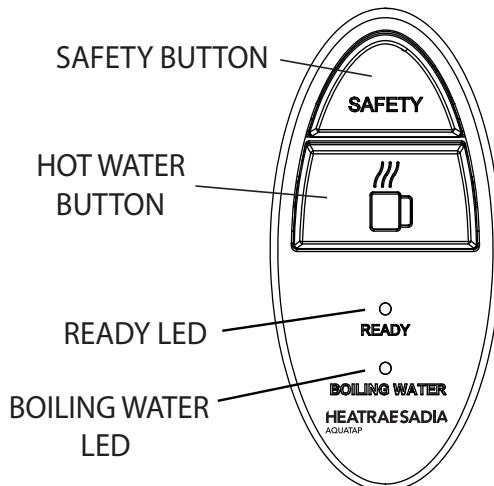

10.7 The “READY” indicators will continue to flash until the heater is full and has self-calibrated to the correct boiling temperature. At this point the “READY” indicators will stop flashing and remain illuminated. If the calibration procedure is interrupted it will restart after a short delay but may result in the calibration temperature being too low. Should this occur the electrical supply should be switched off for several seconds. When switched on again the calibration sequence will re-commence and the “READY” indicators will again flash. Wait until the ready indicators remain illuminated before use. **DO NOT DRAW ANY WATER OFF DURING THE SELF COMMISSIONING MODE.**

10.8 The Aquatap unit and dispenser tap should now be flushed to remove any installation residues and pasteurise the surfaces in contact with the water.

10.9 To dispense hot water press the button marked “SAFETY” on the dispenser tap (the safety button must be released before the dispense button can be activated. You have a 5 second window in which to start dispensing) followed by the HOT water button (red). The hot water dispensing button must remain pressed for the water to flow. If released, it will be necessary to press the “SAFETY” button again before more water can be dispensed.

FIGURE 11 : OPERATING BUTTONS

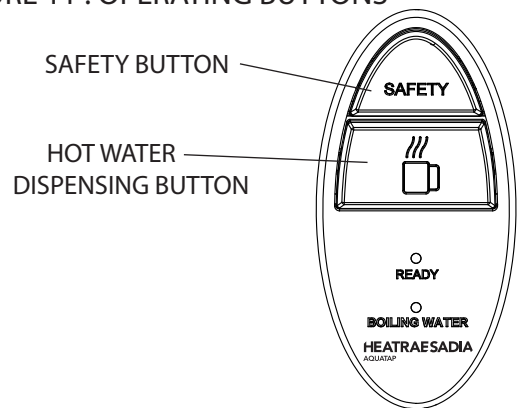

10.10 Following flushing it is recommended that the power is switched off and the Aquatap casing removed to check for any internal leaks.

Always disconnect the electrical supply before removing the cover.

If there are no leaks evident, replace and secure the front casing. Switch on the electrical supply.

The “READY” indicators will illuminate on the Aquatap heater unit and dispenser tap. The “READY” indicator will flash for a short time as the unit re-calibrates and checks the correct fill level. When the “READY” indicators stop flashing and remain solid the Aquatap unit will be ready for use.

10.11 Following commissioning, the following should be explained to the user:

- Correct operation of the Aquatap water heater and dispensing tap.
- Advise the position of the water and electrical isolation points.
- How to identify if there is a malfunction of the unit. Explain that in the event of a malfunction of the unit or dispenser tap any maintenance or servicing must only be carried out by a competent installer.
- Explain the necessity for regular maintenance of the system to ensure continued safe and efficient operation.
- Draw the users attention to section 11.0 page 17 of these instructions which detail the correct use of the system.

10.12 The commissioning record should be completed (see section 15.0, page 28).

10.13 These instructions should be left with the user for future reference.

11.0 USER INSTRUCTIONS

11.1 Once installed and commissioned the filling and heating cycles of the Aquatap are completely automatic. The indicator lights on the dispensing tap will indicate the status of the system. If the “READY” light is flashing this indicates that the unit is self-calibrating, the Aquatap will enter this mode after any period of the electrical supply being switched off. DO NOT draw off water whilst the “READY” light is flashing. When the “READY” light stops flashing and remains illuminated the unit will be ready to dispense boiling water.

FIGURE 12 : LED POSITIONS

11.2 Hot water drawn from the dispensing tap will at all times be close to boiling point so due caution must be taken when using the product, especially if it is likely to be used by children, aged or infirm persons.

11.3 Hot water cannot be dispensed unless the safety lock is turned off. The button marked “SAFETY” should be pressed before the hot water dispensing button. The dispensing button must be held in the pressed position to continue dispensing. If it is released, the “SAFETY” button must be pressed again before more hot water can be dispensed.

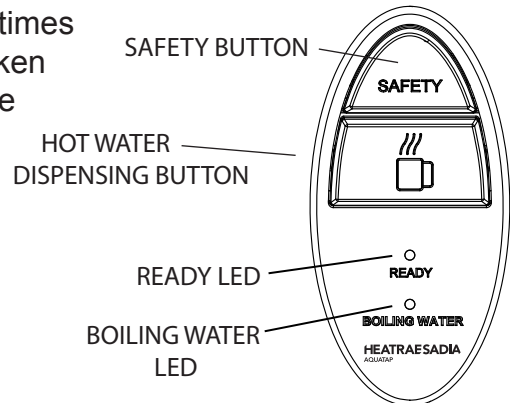

11.4 In the unlikely event that the full store of hot water is completely drawn off from the Aquatap the pump will stop and flow from the dispenser will be interrupted. This is to prevent air being drawn through the pump and it possibly air locking, it does not indicate a fault with the heater. Should this happen the “READY” indicator will flash. After a few minutes the unit will have re-filled to a level where hot water can again be drawn, this will be indicated by the “READY” indicator remaining lit. If air becomes captive in the pump, operate the dispense sequence to remove the air trapped in the pump. It does not indicate a fault with the heater.

11.5 If the Aquatap is not used for a few days the stored water may become “stale”. In these instances it is advisable to draw off and discard the entire contents to flush through the “stale” water. This will ensure that freshly boiled water is available for dispensing.

11.6 Occasionally some scale residue may be drawn from the unit with the dispensed water which may cause the water to appear “milky” for a short while. This is completely harmless and will quickly clear if left to stand. Alternatively a few cups of water can be dispensed and discarded until the water flows clearly.

FIGURE 13: EXPLODED VIEW FOR STEAM TRAP REMOVAL AND DESCALING

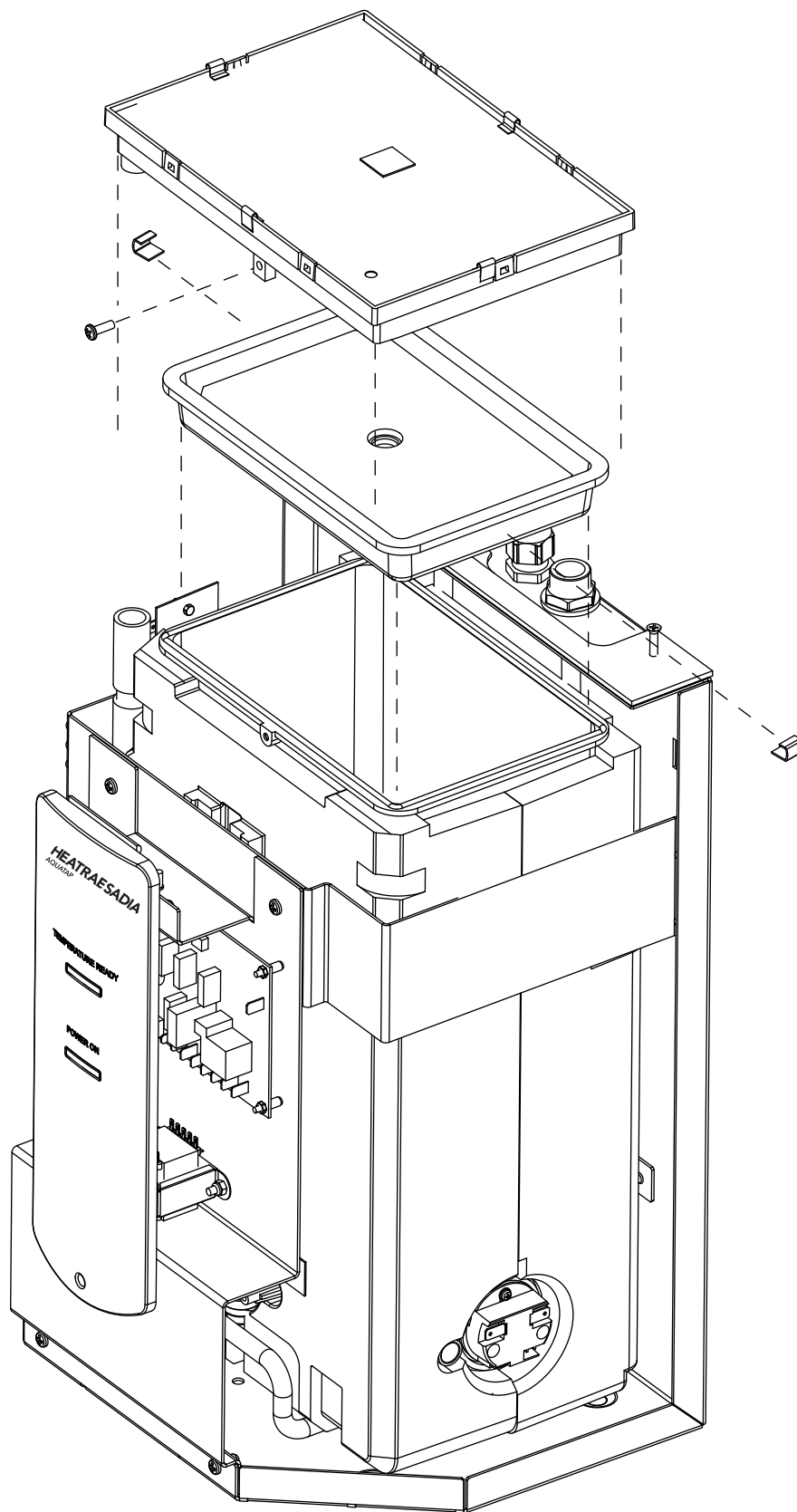

13.0 FAULT FINDING - AQUATAP HEATER

SYMPTOM	POSSIBLE CAUSE	ACTION
No indicator lights on heater	<ol style="list-style-type: none"> 1. If no water or heat - no power to unit 2. If hot water available - no power to indicator lights 	<ol style="list-style-type: none"> 1. Check power supply is correctly connected and switched on. Check primary cut-out has not operated 2. Check wiring harness to indicator lights is plugged into control PCB
Heater does not fill on commissioning	<ol style="list-style-type: none"> 1. If POWER on indicator is not lit - no power to unit 2. If TEMPERATURE READY indicator flashing - water supply not turned on. 3. Solenoid valve fault 4. Low water pressure 5. Inlet pipe blocked 	<ol style="list-style-type: none"> 1. Check power supply is correctly connected and switched on. Check primary cut-out has not operated 2. Check water supply 3. Check solenoid operation, replace if necessary 4. Check water is turned on and supply pressure exceeds minimum requirements, 0.5 bar 5. Check inlet pipe filter is not obstructed
Heater does not heat up on commissioning	<ol style="list-style-type: none"> 1. If POWER on indicator is not lit - no power to unit 2. If TEMPERATURE READY indicator flashing - water supply not turned on. 3. Solenoid valve fault 4. Low water pressure 5. Element fault 	<ol style="list-style-type: none"> 1. Check power supply is correctly connected and switched on. Check primary cut-out has not operated 2. Check water supply 3. Check solenoid operation, replace if necessary 4. Check water is turned on and supply pressure exceeds minimum requirements 5. Check element operation, if faulty replace
Heater does not fill after commissioning	<ol style="list-style-type: none"> 1. Level sensor fault 2. Solenoid valve fault 3. Electronic control PCB fault 4. Low water pressure 5. Inlet pipe blocked 	<ol style="list-style-type: none"> 1. Check level sensor earth connection 2. Check solenoid operation, replace if necessary 3. Check all connections to the control PCB, replace if necessary 4. Check water is turned on and supply pressure exceeds minimum requirements 5. Check inlet pipe filter is not obstructed
Heater does not heat up after commissioning	<ol style="list-style-type: none"> 1. Element fault 2. Electronic control PCB fault 3. Control thermistor fault - short circuit 	<ol style="list-style-type: none"> 1. Check element operation, if faulty replace 2. Check all connections to the control PCB, replace if necessary 3. Check continuity
Water flow from vent and primary cut-out operates	<ol style="list-style-type: none"> 1. Solenoid valve fault 2. Level sensor fault 3. Electronic control PCB fault 4. Inlet pipe blocked 	<ol style="list-style-type: none"> 1. Check solenoid operation, replace if necessary 2. Check level sensor earth connection 3. Check all connections to the control PCB, replace if necessary 4. Check inlet pipe filter is not obstructed

SYMPTOM	POSSIBLE CAUSE	ACTION
Steam from vent pipe and primary cut-out operates	<ol style="list-style-type: none"> 1. Control thermistor fault - open circuit 2. Electronic control PCB fault 3. Scale build up 	<ol style="list-style-type: none"> 1. Check continuity 2. Check all connections to the control PCB, replace if necessary 3. Descale unit
Water consistently cooler than when new	<ol style="list-style-type: none"> 1. Control thermistor pocket has a covering of scale 2. Control thermistor out of calibration 3. Steam thermistor out of calibration 4. Water was drawn off during commissioning mode 	<ol style="list-style-type: none"> 1. Descale unit, clean pocket surface 2. Check thermistor values (5kΩ at 100 °C, 100kΩ at 25 °C) 3. Check thermistor values (5kΩ at 100 °C, 100kΩ at 25 °C) 4. Recommission heater

13.0 FAULT FINDING - AQUATAP DISPENSER

SYMPTOM	POSSIBLE CAUSE	ACTION
Indicator lights on heater, but not on dispenser	<ol style="list-style-type: none"> 1. Dispensing tap control cable not connected to heater 2. Dispensing tap PCB fault 	<ol style="list-style-type: none"> 1. Check that dispensing tap control cable is connected to heater 2. If tap control is correctly connected, check and if necessary replace dispensing tap PCB
No water flow when dispenser button pressed	<ol style="list-style-type: none"> 1. Solenoid valve fault 2. Pump not operating 3. Dispensing tap PCB fault 4. Control box PCB fault 5. Inlet pipe blocked 	<ol style="list-style-type: none"> 1. Check solenoid operation, replace if necessary 2. Check supply to pump. If necessary replace pump 3. Check tap control cable 4. Check all connections to control box PCB 5. Check inlet pipe filter is not obstructed

14.0 SPARE PARTS

DISPENSER ASSEMBLY

1	Top of dispenser kit	95 607 377
2	Dispensing tap circuit board and harness	95 615 071
3	Pipe kit (2 pipes)	95 607 381
4	Dispensing tap "C" clamp assembly	95 607 382
5	Tube spanner (not shown)	95 607 384

HEATER ASSEMBLY

10	Hose clip kit	95 607 361
11	Vent pipe manifold	95 607 370
12	Hose long	95 607 371
13	Primary cutout (mounted on internal vent pipe)	95 612 001
14	Pump assembly	95 607 372
15	Level sensor assembly	95 615 072
16	Hose short	95 607 373
17	Inlet pipe assembly	95 607 374
18	Solenoid valve assembly	95 607 359
20	Manifold assembly solenoid to tank	95 615 073
21	Washer	95 607 735
22	Control circuit board	95 615 066
23	Steam condenser assembly	95 607 016
24	Transformer	95 607 376
25	Condenser sealing gasket	95 611 819
26	O ring kit	95 611 002
27	Tank	95 608 927
28	Element assembly 2.5kW (incorporating start dry cutout)	95 606 952
29	Element assembly sealing gasket	95 611 816
30	Adaptor nut, tube & washer kit	95 607 333
31	Start dry cutout (element)	95 612 691
32	Cover assembly and screws	95 614 129
33	Wiring harness complete (not shown)	95 612 054
34	Indicator light wiring harness (not shown)	95 612 055
35	Tap assembly complete (boil only)	95 607 362
36	Hose and clip assembly (boil and vent)	95 607 364
37	Heater unit complete	95 607 329
38	Thermistor control/steam	95 612 696
39	Screen vent filter	95 607 719

FIGURE 14 : EXPLODED VIEW OF DISPENSER

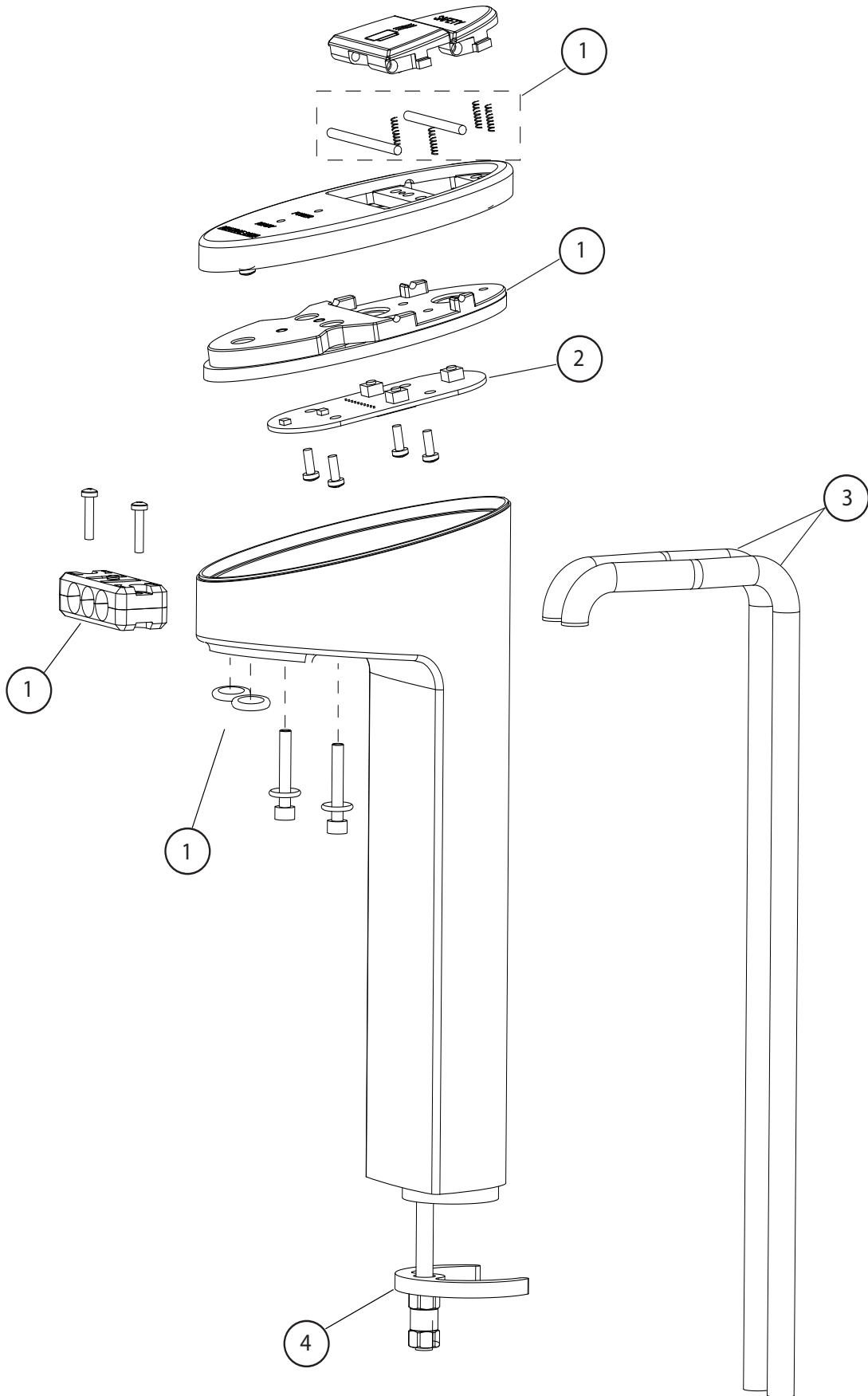

FIGURE 15: EXPLODED VIEW HEATER ASSEMBLY

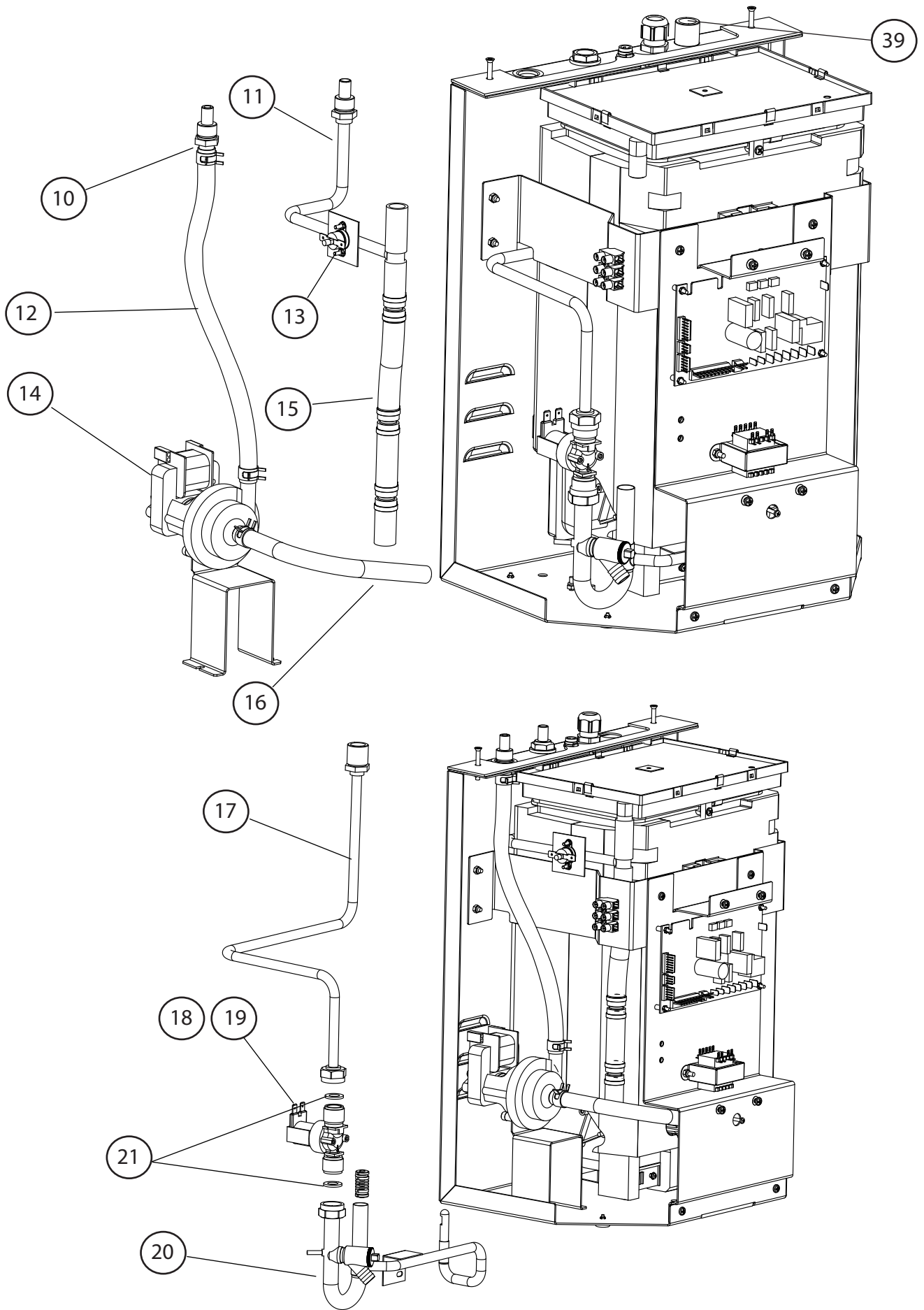

FIGURE 16: EXPLODED VIEW HEATER ASSEMBLY

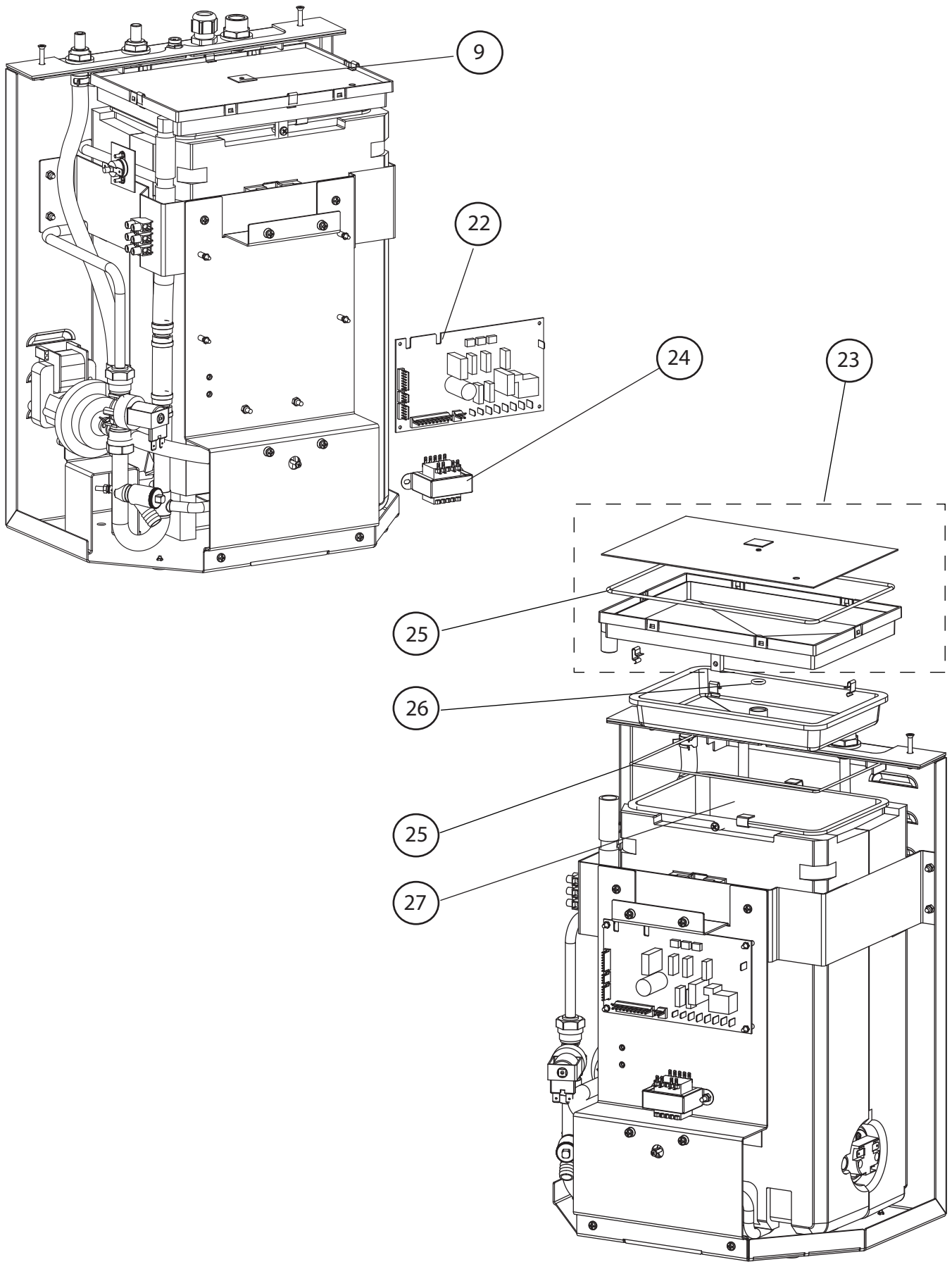

FIGURE 17 : EXPLODED VIEW HEATER

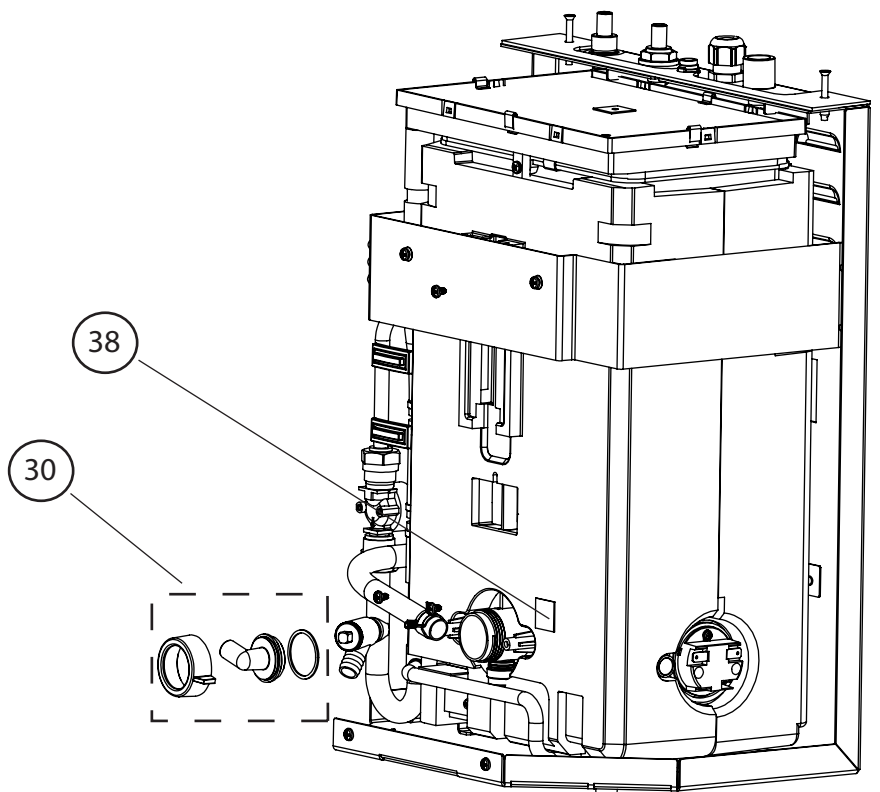
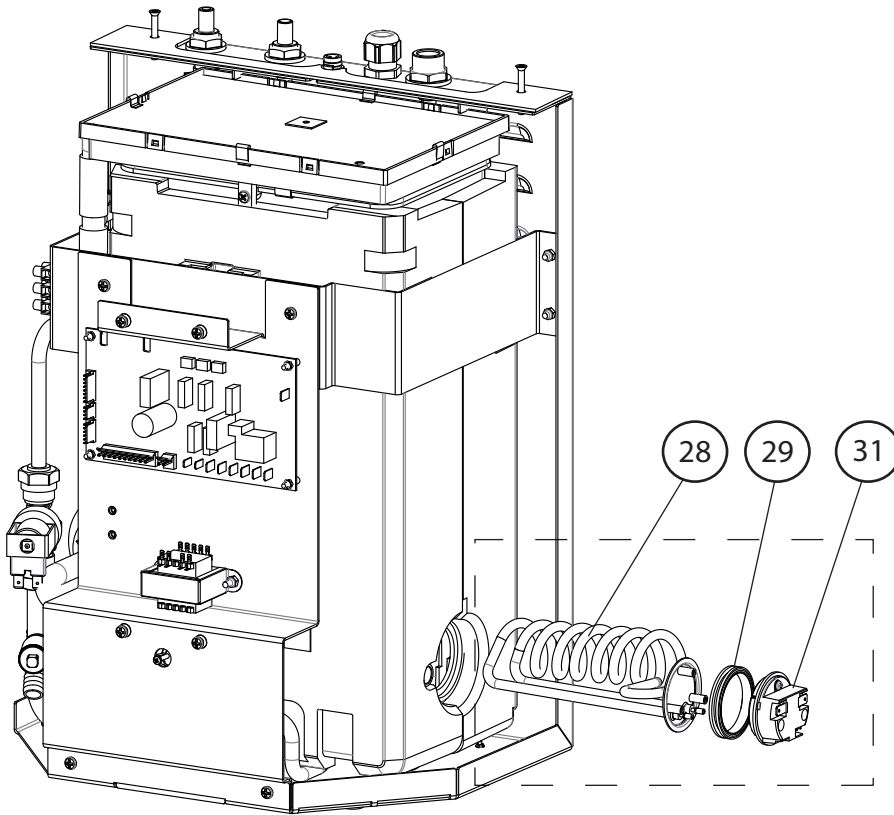
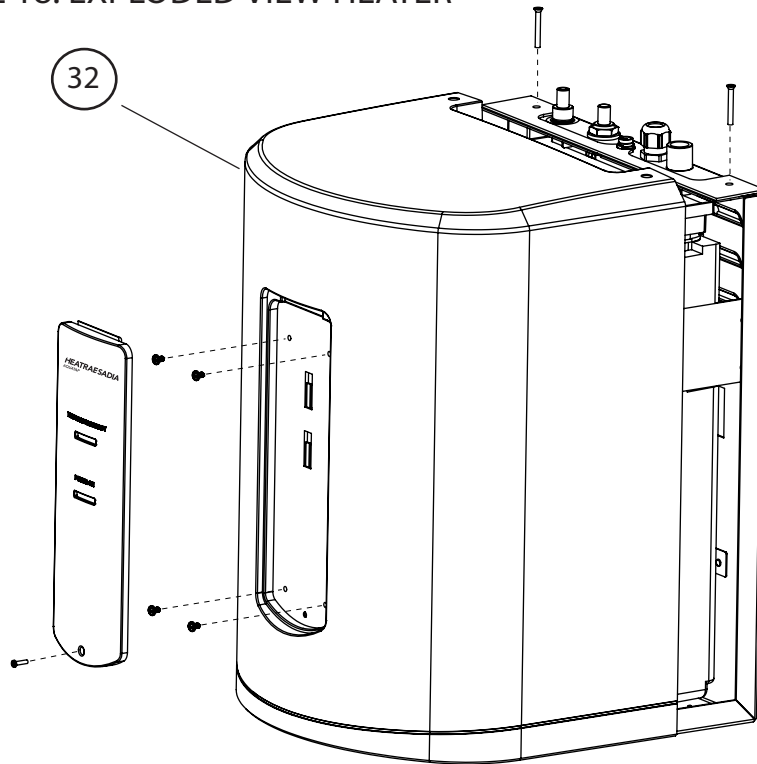

FIGURE 18: EXPLODED VIEW HEATER



GUARANTEE

This Aquatap water heater and dispensing tap assembly is guaranteed for a period of two years from the date of purchase provided:

- Both the Aquatap water heater unit and dispensing tap assembly have been installed in accordance with these instructions and all necessary water, vent and electrical connections have been fitted correctly.
- Any valves or controls are of Heatrae Sadia recommended type.
- The unit has not been tampered with and has been regularly maintained as detailed in the maintenance instructions.
- Only a recommended Aquatap dispensing tap assembly has been used to deliver the boiling water.
- The unit has been used only for heating wholesome (potable) water.

The unit and dispensing tap assembly are not guaranteed against damage by frost or due to the build up of scale. Please note that if heateam (Heatrae Sadia's service division) personnel or agents are requested to descale a unit, this work will be chargeable.

Guarantee valid for U.K only.

This guarantee does not affect the statutory rights of the consumer.

The pace of product development is such that we reserve the right to change product specifications without notice. We do however, strive to ensure that all information in this leaflet is accurate at the time of publication.

ENVIRONMENTAL INFORMATION

This product is manufactured from many recyclable materials. At the end of its useful life it should be disposed of at a Local Authority Recycling Centre. Do not dispose of the unit in the general household waste.

15.0 COMMISSIONING RECORD

Installation Date: _____
Model and Serial Number: _____
Installer (Plumbing): _____
Contact Details: _____
Competency Scheme & ID Number: _____
Installer (Electrical): _____
Contact Details: _____
Competency Scheme & ID Number: _____
Comments: _____

Mains supply pressure and flow rate	
Isolation valve fitted	
Pipework checked for leaks	
Pipework bonded	
Electrical connections checked	
Filtered Flow rate	
Boiling Flow rate	
Boiling Temperature	

16.0 SERVICE RECORD

Service Date: _____

Engineer: _____

Contact Details: _____

Competency Scheme & ID Number: _____

Comments: _____

Actions Carried Out: _____

Service Date: _____

Engineer: _____

Contact Details: _____

Competency Scheme & ID Number: _____

Comments: _____

Actions Carried Out: _____

Service Date: _____

Engineer: _____

Contact Details: _____

Competency Scheme & ID Number: _____

Comments: _____

Actions Carried Out: _____

Service Date: _____

Engineer: _____

Contact Details: _____

Competency Scheme & ID Number: _____

Comments: _____

Actions Carried Out: _____

NOTES:

NOTES:

SPARES STOCKISTS:

Advanced Water Company Ltd
Unit D5 Enterprise Way
Vale Park, Evesham
Worcs, WR11 1GS
T: 01386 760066
F: 01386 760077

Electric Water Heating Co
2 Horsecroft Place, Pinnacles,
Harlow, Essex, CM19 5BT
T: 0845 055 3811
E: sales@ewh.co.uk

SPD
Units 9 & 10 Hexagon Business Centre
Springfield Road, Hayes,
Middlesex, UB4 0TY
T: 020 8606 3567

Parts Center
T: 0845 270 9800
W: www.partscenter.co.uk

Newey & Eyre
Unit 3/4/5 Wassage Way
Hampton Lovett Industrial Estate
Droitwich, Worcestershire, WR9 0NX
T: 01905 791500
F: 01905 791501

UK Spares Ltd
Unit 1155, Aztec West,
Almondsbury, Bristol, BS32 4TF
T: 01454 620500

William Wilson Ltd
Unit 3A, 780 South Street,
Whiteinch, Glasgow, G14 0SY
T: 0141 434 1530

Alternatively contact your local supplying
merchant or wholesale branch.