

HEATRAESADIA

SMARTER | CLEANER | WARMER

Handy No Touch Electric Handwash Fitting Instructions

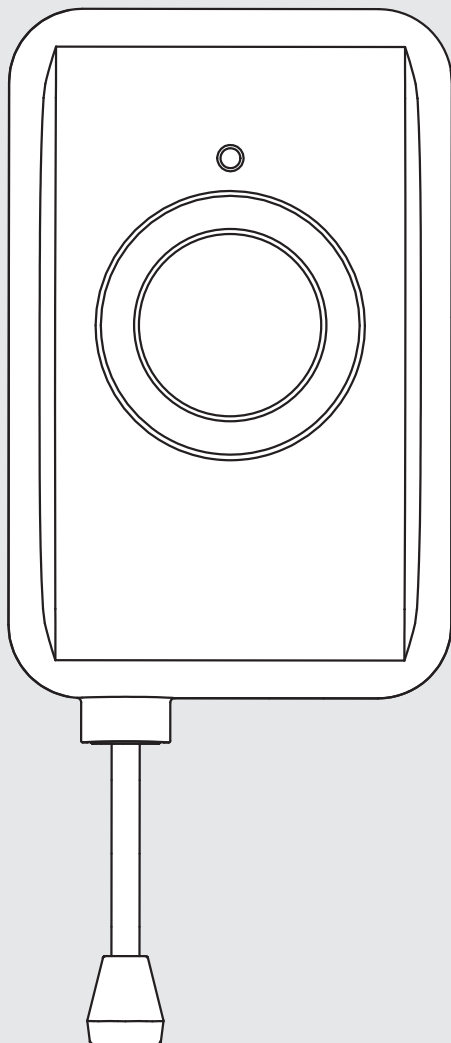

Contents

1. Introduction	3
1.1 General	3
1.2 Symbols used.....	3
1.3 Abbreviations.....	3
1.4 Liabilities	3
2. Safety	4
2.1 General safety warnings	4
2.2 Recommendations	4
2.3 Specific safety instructions.....	4
3. Technical specifications	5
3.1 Technical data	5
3.2 Dimensions and connections	5
3.3 Electrical diagram(s)	6
4. Description of the product	7
4.1 General description	7
4.2 Operation principle	7
4.3 Standard delivery	7
4.4 Main components	7
5. Before installation	8
5.1 Installation regulations	8
5.2 Installation requirements	8
5.3 Choice of location.....	9
6. Fitting Instructions	10
6.1 General	10
6.2 Water connections.....	10
6.3 Electrical connections	11
7. Commissioning	12
7.1 General	12
7.2 Checklist before commissioning.....	12
7.3 Commissioning procedure	12
8. Operation	12
8.1 General	12
9. Maintenance	13
9.1 General	13
10. Troubleshooting	14
10.1 Decommissioning procedure.....	14
11. Spare parts	15
Warranty	15

 This product can be used by children aged from 8 years and above and persons with reduced physical sensory or mental capabilities or lack of experience and knowledge if they have been given supervision or instruction concerning use of the product in a safe way and understand the hazards involved. Children shall not play with the product. Cleaning and user maintenance shall not be made by children without supervision. Children must be supervised to ensure they do not play with the product.

1. Introduction

1.1 General

The following instructions are offered as a guide to the user and installer.

The installation must be carried out by a competent plumbing and electrical installer in accordance with Building Regulation G3 (England and Wales), Technical Standard P3 (Scotland) or Building Regulation P5 (Northern Ireland) and the Water Fitting Regulations (England and Wales) or Water Byelaws (Scotland).

1.2 Symbols used

In these instructions, various risk levels are employed to draw the user's attention to particular information. In doing so we wish to safeguard the user, avoid hazards and guarantee the correct operation of the product.



WARNING

Risk of dangerous situation causing slight physical injury.



CAUTION

Risk of material damage.



Signals important information.

1.3 Abbreviations

- ▶ PRD – Pressure relief device
- ▶ RCD – Residual current device
- ▶ MCB – Miniature circuit breaker

1.4 Liabilities

Manufacturers liability

Our products are manufactured in compliance with the requirements of the various applicable European Directives.

This product complies with the requirements of the CE marking directive.

In the interest of UK customers, we are continuously endeavouring to make improvements in product quality. All the specifications stated in this document are therefore subject to change without notice.

Our liability as the manufacturer may not be invoked in the following cases:

- ▶ Failure to abide by the instructions on using the product.
- ▶ Faulty or insufficient maintenance of the product.
- ▶ Failure to abide by the instructions on installing the product.

Installer's liability

The installer is responsible for the installation and the commissioning of the product. The installer must respect the following instructions:

- ▶ Read and follow the instructions given in the manuals provided with the product.
- ▶ Carry out installation in compliance with the prevailing legislation and standards.
- ▶ Perform the initial start up and carry out any checks necessary.
- ▶ Complete the commissioning checklist.
- ▶ Explain the installation to the user.
- ▶ If maintenance is necessary, warn the user of the obligation to check the product and maintain it in good working order.
- ▶ Give the instruction manual to the user.

Users liability

To guarantee optimum operation of the product, the user must respect the following instructions:

- ▶ Read and follow the instructions given in the manuals provided with the product.
- ▶ Call on qualified professionals to carry out installation and initial start-up.
- ▶ Get your installer to explain your installation to you.
- ▶ Have your required checks and services done.
- ▶ Keep the instruction manuals in good condition and close to the product.

2. Safety

2.1 General safety warnings



WARNING

ISOLATE the electrical and water supplies before removing the cover.

ISOLATE the electrical and water supplies BEFORE proceeding with installation or servicing.

DO NOT operate the product if:

- ▶ It is frozen or suspected of being frozen. See fault finding table on page 14.
- ▶ Water ceases to flow during use.
- ▶ Water has entered inside the product because of an incorrectly fitted cover.
- ▶ The product is damaged.



CAUTION

- ▶ DO NOT tile up to the product after fixing to the wall.
- ▶ The sprayplate must be cleaned when any of its holes become blocked, otherwise restriction to the flow from the outlet spout will result in higher temperatures and could also cause the pressure relief device in the appliance to operate - see 9.1 p13.
- ▶ The product is NOT SUITABLE for mounting into steam rooms or steam cubicles.

2.2 Recommendations



WARNING

The plumbing installation must comply with Water Regulations.

The supply pipe must be flushed to clear debris before connecting to the product.

DO NOT solder pipes or fittings within 300mm once the pipework is located in the product, as heat transfer can damage components.

DO NOT fit any form of outlet flow control as the outlet acts as a vent for the heater can.

DO NOT use excessive force when fitting the spout fixing nut, finger tightness is sufficient.

All plumbing connections must be completed and checked for leaks before making the electrical connections.

2.3 Specific safety instructions



WARNING

Before fitting the product, ensure that the consumer unit and any switches are suitable for the additional load. If in doubt contact your electricity supplier or a qualified electrician.

The installation must comply with BS 7671 'Requirements for electrical installations' (IEE Wiring Regulations).

3. Technical specifications

3.1 Technical data

Model numbers

3.1kW - Handwash - 95 020 115

Supplier's name or trade mark	Heatrae Sadia
Supplier's model identifier	Handy 3 NT
The declared load profile	XXS
The water heating energy efficiency class of the model	A
The water heating energy efficiency in %	38.6
The annual electricity consumption in kWh	478
Daily fuel consumption in kWh	2.200
Specific precautions that shall be taken when the water heater is assembled, installed or maintained and disposed of at end of life	See Section 3 to 11

Table: Technical parameters in accordance with European Commission regulations 814/2013 and 812/2013

3.2 Dimensions and connections

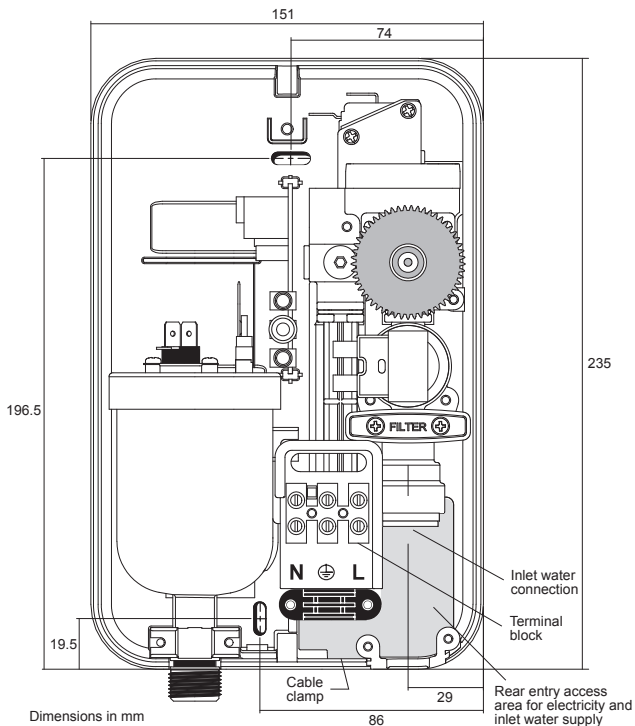

Figure 1

Dimensions in mm

3.3 Electrical diagram(s)

Nominal Power Rating

Model	240V	230V	Minimum cable size
3.1kW	3.1kW 12.9 amp	2.9kW 12.4 amp	1.5mm ²

Materials

Backplate, cover and control knob - ABS

Element(s) - Copper sheathed rod type.

Dimensions

Height - 235mm

Width - 151mm

Depth - 85mm

Standards and approvals

Complies with the requirement of EN 60335-2-35.

Complies with European Community Directives (CE). kiwa approved.

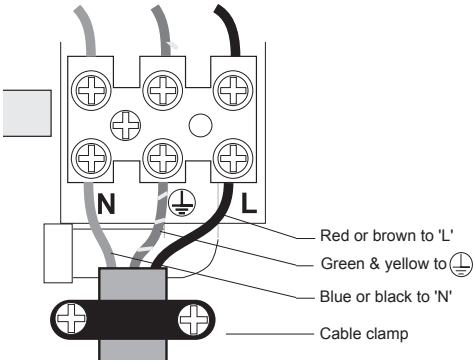

Figure 2 – Electrical connection

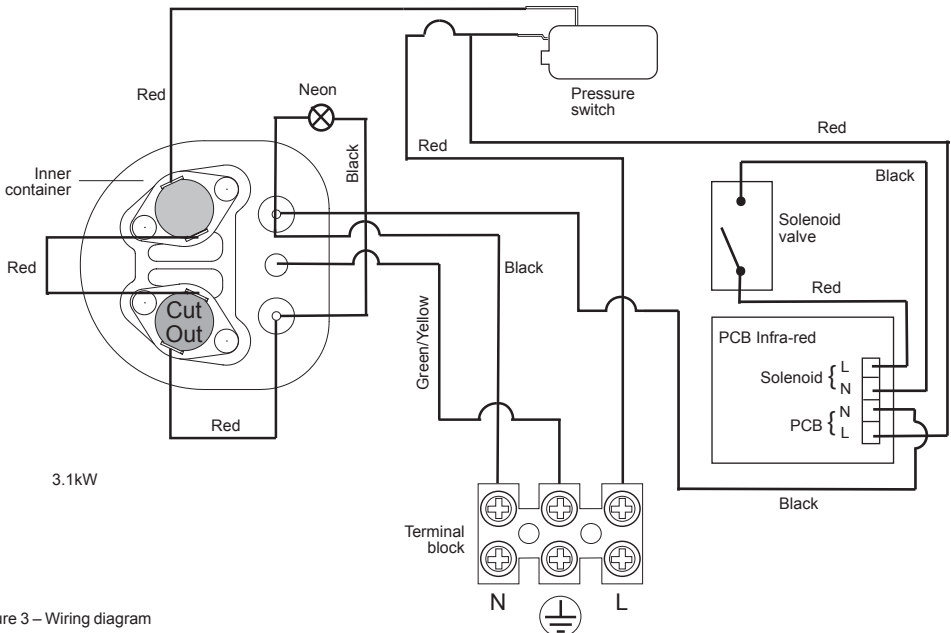

Figure 3 – Wiring diagram

4. Description of the product

4.1 General description

This product is manufactured to British and European Standard. These products are safe and without risk provided they are installed, used and maintained in good working order in accordance with our instructions and recommendations.

Please read and understand these instructions before starting work and retain them for later use.

This product is a purpose designed handwash heater. The unit has a cooper sheath element contained in a high grade plastic canister, this with the flow control valve is assembled into high quality ABS plastic backplate and front cover.

4.2 Operation principle

The product is used to provide the user with hot water for hand washing.

By turning on the control valve water flows through the product which then switches the element on to heat the water.

4.3 Standard delivery

Pack contents

- ▶ Heater
- ▶ Spout assembly
- ▶ Fixing screws and plugs
- ▶ Installation and user Instructions

4.4 Main components

See Figure 4

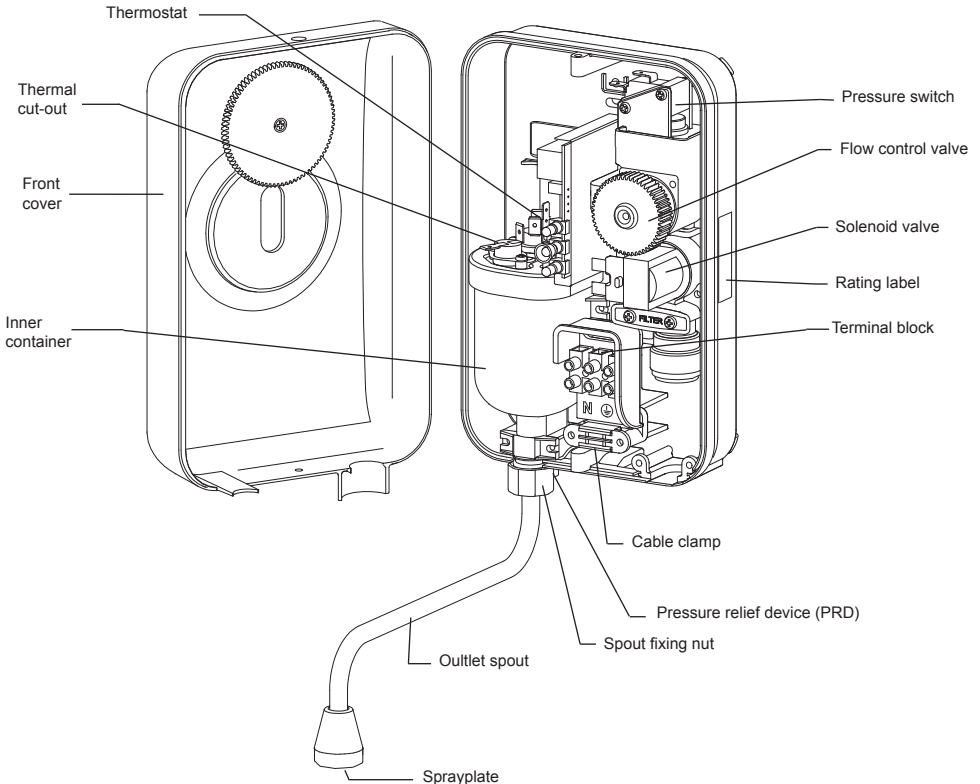

Figure 4 – Internal components

5. Before installation

5.1 Installation regulations



WARNING

Installation of the product must be carried out by a qualified engineer in accordance with prevailing and national regulations as listed below.

- ▶ Building Regulations
- ▶ The Building Standards (Scotland)
- ▶ The Building Regulations (Northern Ireland)
- ▶ I.E.E Electrical Regs
- ▶ UK Water Regulations

5.2 Installation requirements

Pipe entry

Plumbing entry can be from the rear (preferred) or from the bottom. The backplate has a cut out position to suit 15mm pipe. When opting for bottom entry make the cut out before fitting the backplate to the wall - see figure 5 below.

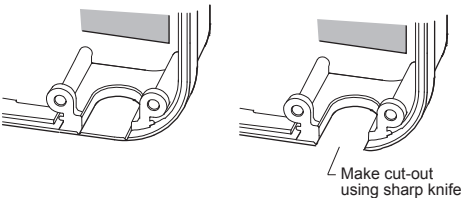

Figure 5 – Plumbing cut-out

Water requirements

The installation must be in accordance with Water Regulations. To ensure activation of the heating elements, the handwash must be connected to a mains water supply with a minimum running pressure of 0.1 MPa (1 bar) and a maximum static pressure of 0.7 MPa (7 bar). If static pressure exceeds 0.7 MPa (7 bar) fit a pressure reducing valve to avoid damaging the product. If in doubt, the pressure should be checked taking account of other services from the same water supply which could cause the pressure to fall below the minimum. The water supply can also be taken from a cold water storage cistern provided there is a minimum head of 10m above the product.

If the product is operated outside of the stated pressure parameters it may not be possible to achieve optimum performance from the product throughout the year.



WARNING

- ▶ The product must be earthed
- ▶ **IMPORTANT - INSTALLATION TO BE CARRIED OUT BY A COMPETENT INSTALLER**

Electrical requirements

The installation supply cable and circuit protection must conform to BS 7671.

Before making any sort of electrical connection, ensure that no terminal within the circuit is live. If in any doubt SWITCH OFF the whole installation at the consumer unit.

The product must only be connected to a 230-240V ac supply.

The earthing and protective conductor arrangement within the property, in particular the supplementary bonding in the room containing the product, must comply with BS 7671.

Ensure that the supply cable and fuse are sufficient for the rated input of your unit. Please refer to the rating label within the product.

A minimum heat resistance cable size of 1.5mm² should be used.

The product can be connected in two different ways:

- ▶ Via a fused and switched connection unit taken as a spur from a 13amp ring main.
- ▶ As a separate circuit taken directly from a spare way in a consumer unit.

In each case a double pole isolating switch having a contact separation of at least 3mm in each pole, and a minimum rating of 13amp must be incorporated in the wiring of the appliance.

5.3 Choice of location

The product must be mounted on a flat surface, which covers the full width and length of the backplate. It is important that the wall surface is flat otherwise difficulty may be encountered when fitting the cover.

Ensure that the product is positioned over the basin, if the PRD operates, water will eject from the bottom of the product.

The outlet of the product acts as a vent and **MUST NOT** be connected to any form of outlet flow control, or any other fitting not recommended by the manufacturer.

WARNING

DO NOT fit the product to the wall and tile up to the case. It must be fitted on to a finished flat and even wall surface. This allows removal for servicing.

The control knob is an integral part of the cover - do not attempt to remove it.

Position the product above the basin so that the spray will be contained within the basin and at a convenient height for hand washing see figure 7 below.

Double pole isolating switch: pull cord or wall mounted in accordance with IEE regulations

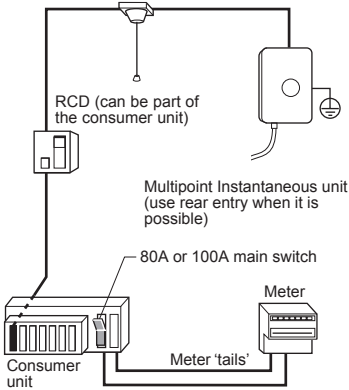

Figure 6 – schematic of typical electrical layout

Fuses do not give personal protection against electric shock. To enhance electrical safety a 30mA residual current device (RCD) should be installed in all electric handwash circuits. This may be part of the consumer unit, or a separate unit.

Ensure that all terminal block connections are sufficiently tight.

Switch off the product immediately and isolate if water ceases to flow during use.

Other electrical equipment e.g. extractor fans, must not be connected to the product or its supply circuit.

To obtain full advantage of the power provided by the product, use the shortest cable route possible from the consumer unit to the product.

If your consumer unit has a rating below 80A, or if there is no spare fuse way, then the installation will not be straightforward and may require a new consumer unit. A qualified electrician should install the new consumer unit. It may be necessary to contact your electrical supplier to upgrade your supply.

CAUTION

To enhance electrical safety a 30mA residual current device (RCD) should be installed in all electric handwash circuits. This may be part of the consumer unit or a separate unit. **DO NOT** use a rewirable fuse, instead use a suitably rated miniature circuit breaker (MCB) or cartridge fuse. The handwash must be connected to its own independent electrical circuit.

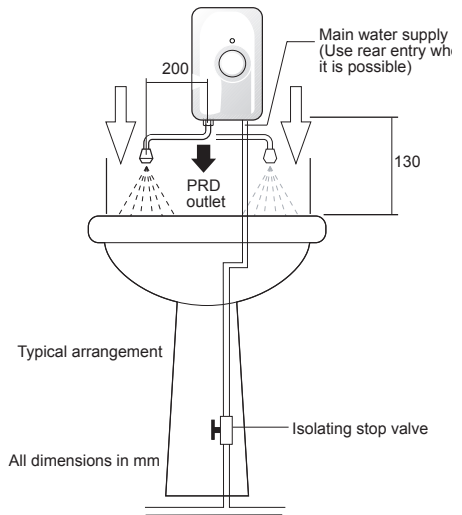

Figure 7 – Handwash position over basin (or sink)

A clearance of at least 130mm above and below the product should be allowed for access to the cover screws.

Cable entry can be from the rear (preferred) or from the bottom. The backplate has cut-out positions to suit the size of the cable. When opting for bottom entry make the cut-out to suit the cable before fitting the backplate to the wall - see figure 8 below.

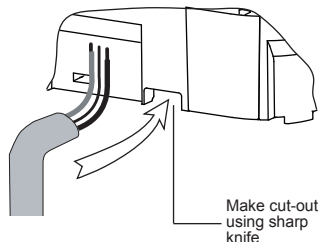

Figure 8 – Bottom entry cable cut-out

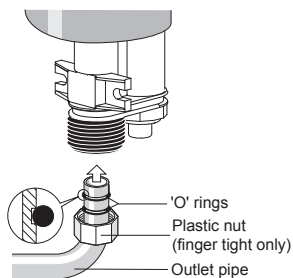

Figure 10 – Fitting outlet spout

After choosing the correct site for the product, use the backplate as a template and mark the two fixing holes.



WARNING

BEWARE OF CABLES AND PIPES WHICH MAY BE BURIED IN THE WALL.

Drill holes using a 6.5mm diameter masonry drill.

Use plugs to suit the wall and use the fixing screws supplied.

6. Fitting Instructions

6.1 General

After reading the previous sections in this booklet and choosing a good location for the product please install, paying attention to the following plumbing, electrical and commissioning sections.

TURN OFF the water and electrical supply.

The product is designed for bottom and rear entries of water and electric cable. It is advisable to use the rear entry (when it is possible), in order to obtain a neater installation.

Unscrew the retaining screws and lift the cover from the back plate - see figure 9 below.

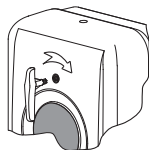

Figure 9 – Removing cover

Fit the outlet spout - DO NOT over tighten, finger tight will be sufficient - see figure 10.

6.2 Water connections

The outlet spout can be removed to ease installation.

The product has been designed for a 15mm water pipe using the pushfit connection - see figure 13.

Decide where to connect the cold water mains feed to the product. Ensure the pipe you have selected is not a gas pipe or a hot water pipe. Chrome and stainless steel pipe is not recommended.

An isolating stop valve **MUST** be incorporated to the main water supply to comply with Water Regulations - see figure 7.

Cut all necessary pipework to length with a pipecutter and not a hacksaw. This will minimise the swarf and prevent damage to the sealing o-ring in the pushfit fitting - see figure 11 below.

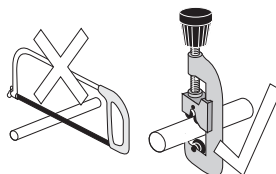

Figure 11 – Cutting pipes

Assemble the installation before making any soldered joints to ensure that the pipe is the correct length. DO NOT use jointing compounds on any pipe fittings for the installation.

CAUTION

Remove the product before soldering the connections.

It is essential to flush the pipe in order to clear debris, particles of solder and swarf - see figure 12 below.

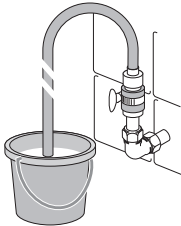

Figure 12 – Flushing the pipework

Turn the water off after flushing using the isolating stop valve.

Connect the cold water supply pipe to the inlet of the product, this is a push fit - see figure 13 below.

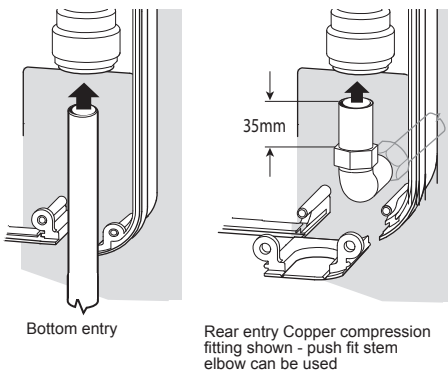

Figure 13 – Pipe connection

Fit top and bottom screws and secure the backplate to the wall ensuring that it is level. See figure 1 for securing positions.

Close the product flow control valve by turning the gear fully anti-clockwise.

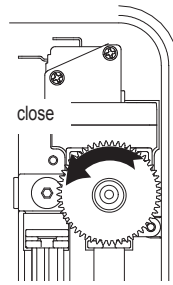

Figure 14 – Gear control valve

Turn the isolating stop valve on slowly and check for leaks in all the pipework, rectify as necessary.

Turn off the isolating stop valve.

6.3 Electrical connections

WARNING

This product must be earthed.

CAUTION

When working on electrical components ensure they are NOT LIVE. If in any doubt, SWITCH OFF THE ELECTRICITY SUPPLY.

A double-pole isolating switch having a contact separation of 3mm in each pole MUST be incorporated to the circuit - see paragraphs 5.2 p8.

The cable entry should have been decided before fitting the backplate - see 5.3 p9.

Remove the screws and clamping bar from the cable clamp - see figure 2 p6.

Feed the cable in the backplate (unscrew backplate for easy feeding if necessary).

Strip the outer sheath of the cable to a point about 5mm above the clamp, thus ensuring that the cable is clamped across its outer sheath.

Strip the insulation from the cores and make connections - see figure 2 p6.

Make sure that all the terminal block screws are sufficiently tight.

Refit the clamp bar.

6.4 Fitting cover

Fit outlet spout if required - see figure 10 p10.

Check that the flow control valve is fully closed by turning the gear fully anti-clockwise.

Turn the control knob until the indicator is between the START and STOP position.

Place the cover onto the back plate.

Secure the cover to the back plate using the screws provided.



WARNING

This product must be earthed.

7. Commissioning

7.1 General

NOTE: The first operation of the product is intended to ensure the heater unit contains water before the product is switched on.

7.2 Checklist before commissioning

Before turning on the electricity and mains water to the hand wash ensure the torx adjusting screw is turned fully anticlockwise – see figure 15 below.

7.3 Commissioning procedure

- ▶ Turn on the electrical supply and main water supply at the isolating stop valve.
- ▶ Place hand in front of appliance sensor to activate solenoid.
- ▶ When water flows constantly from spout turn torx adjusting screw to an acceptable level of flow, appliance will then start to heat water. (You may have to place your hand in front of sensor to keep water flowing) adjust further for acceptable heat.
- ▶ Leave torx adjusting key with customer.

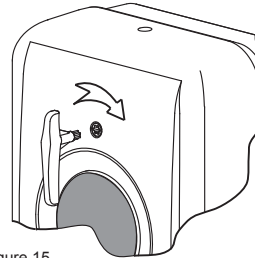

Figure 15

8. Operation

8.1 General

Rotate the control knob half a turn anti-clockwise. After approximately 15 seconds the water will start to heat.

To obtain warmer water turn the control knob clockwise and for cooler water turn anti-clockwise.

Shut off the product by turning the control knob clockwise. The product is now ready to use.

The neon light will illuminate when the water is heating.

9. Maintenance

9.1 General

It is recommended that the product casing be cleaned using a soft cloth and that the use of abrasive or solvent cleaning fluids be avoided. It is advisable that before cleaning, the isolating switch is turned off, thus avoiding accidental operation of the product.



IT IS MOST IMPORTANT TO KEEP THE SPRAYPLATE CLEAN IN ORDER TO MAINTAIN THE PERFORMANCE OF THE HANDWASH. The hardness of the water will determine the frequency of cleaning.



WARNING

This product must be earthed.

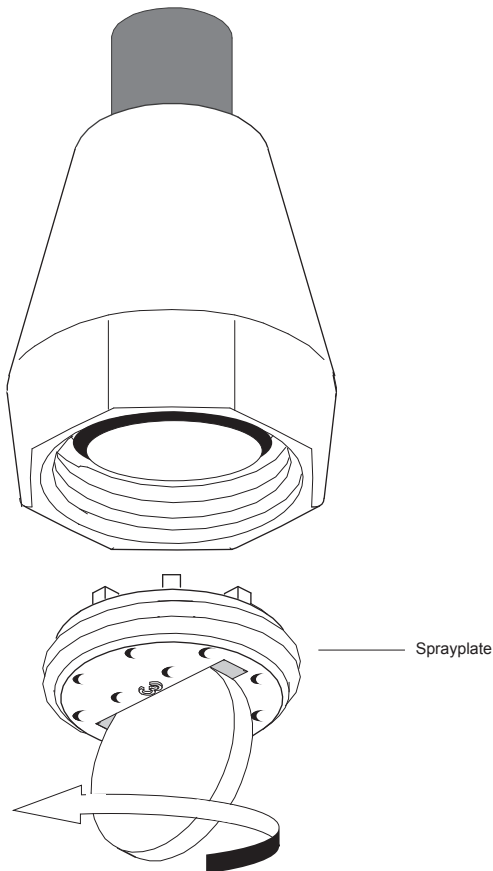

To remove sprayplate unscrew anticlockwise using a coin.

Ensure all holes in sprayplate are clear.

It is recommended to soak the sprayplate overnight in suitable descalant.

DO NOT OVERTIGHTEN when refitting sprayplate.

Figure 16 – Sprayplate

10. Troubleshooting

In the unlikely event of a problem, consult the troubleshooting chart below.

If you are unable to remedy the problem, contact your installer in the first instance.



Do not attempt any electrical or plumbing work unless you are competent to do so.

If you still cannot solve the problem, please contact the manufacturer.

Inspection

It is advisable that, in the interests of safety, the product and its electrical installation is checked by a competent electrician at least every two years.

10.1 Decommissioning procedure

- ▶ Isolate electrical supplies and make safe
- ▶ Isolate the water supply
- ▶ Drain the product
- ▶ Remove the product
- ▶ Cap pipework

Environmental information

Handwash products are manufactured from many recyclable materials.

At the end of their useful life they should be disposed of at a Local Authority Recycling Centre in order to realise the full environmental benefits.

Symptom	Possible cause	Remedy
1. No water flows with valve open	A. Water supply turned off	Turn on water supply
	B. Unit frozen	Turn OFF ELECTRICITY at isolating switch and contact installer. DO NOT USE THE HANDWASH.
	C. Spout blocked	Clean sprayplate - see 9.1 p13
	D. Filter blocked	Clean filter
2. Water too cold	A. Water control knob at wrong setting	Turn knob clockwise until temperature is comfortable
	B. Water flow too high	Turn knob clockwise until temperature is comfortable
	C. Electricity off	Turn on electricity at isolating switch
	D. Poor flow	Check inlet pressure
3. Water too hot	A. Temperature control knob at wrong setting	Turn knob fully anti-clockwise to increase flow and lower temperature
	B. Spout partially blocked	Clean sprayplate - see see 9.1 p13
	C. Isolating valve not fully open	Open isolating valve
	D. Filter blocked	Clean filter
4. Water runs from pressure relief device	A. Spout blocked	Clean sprayplate - see see 9.1 p13, push plastic plunger up and back in place
	B. Spout not blocked	Call a service engineer as there may be a problem with internal parts

11. Spare parts

The following comprehensive list of spare parts is available for your product. Please refer to the rating label on the side of your product before ordering to ensure the correct spare part is obtained.

DO NOT REPLACE WITH PARTS NOT RECOMMENDED AS THIS WILL INVALIDATE YOUR WARRANTY AND MAY RENDER THE INSTALLATION DANGEROUS.

Description	Code No
1 Heat Exchanger Assembly 3.1kW	95 608 003
2 Spout-3.1kW	95 604 002
3 Cut-out - 3.1kW	95 612 029
4 Cut-out - 3.1kW (one shot)	95 612 031
5 Valve/Pressure Switch Assembly - 3.1kW	95 605 052
6 Cover Assembly	95 614 092
7 Neon Assembly	95 615 056
8 Micro switch	95 613 003
9 Filter	95 607 107
10 Pressure Relief Device	95 607 108
11 PCB	95 615 024
12 Solenoid Valve	95 605 058
13 Torx Adjustor	95 607 037

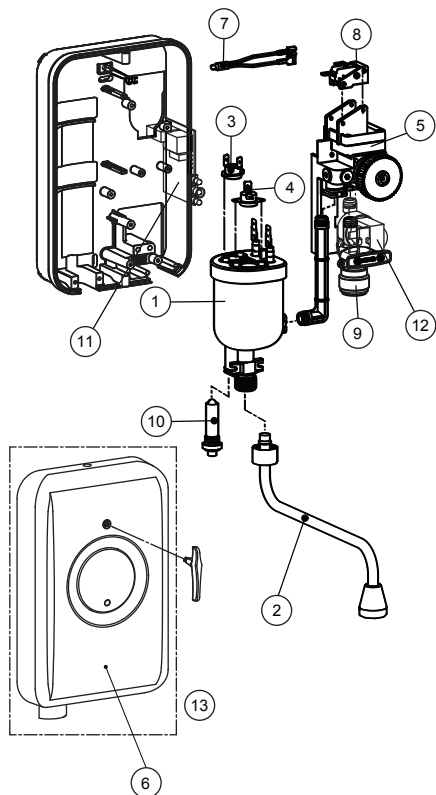

Warranty

Warranty & Service Policy

This product is covered against faulty materials and manufacture for a period of two years from the date of purchase provided that:

- ▶ The product has been installed by a competent person in accordance with the Installation, User instructions, all relevant Codes of Practice, Regulations in force at the time of installation and that all necessary controls and safety valves have been fitted correctly.
- ▶ Any valves and controls are of the Heatrae Sadia recommended type and specification.
- ▶ The product has not been modified or tampered with in any way, and has been regularly maintained as detailed in the Installation and User Instructions.
- ▶ The product has been used only for heating potable water.

The product is not covered against damage by frost, and the inner container with integral heating element is not covered against excessive scale build-up.

This warranty in no way affects the statutory rights of the consumer.

The policy of Heatrae Sadia is one of continuous product development and, as such, we reserve the right to change specifications without notice.

HEATRAE SADIA

SMARTER | CLEANER | WARMER

Electric Water Heating Co.
2 Horsecroft Place
Pinnacles
Harlow
Essex CM19 5BT
Tel: 0845 055 3811
E-Mail: sales@ewh.co.uk

SPD
Special Product Division
Units 9 & 10
Hexagon Business Centre
Springfield Road
Hayes
Middlesex UB4 0TY
Tel: 020 8606 3567

Parts Center
Tel: 0344 292 7057
www.partscenter.co.uk

Newey & Eyre
Unit 3-5 Wassage Way
Hampton Lovett Ind. Estate
Droitwich, Worcestershire
WR9 0NX
Tel: 01905 791500
Fax: 01905 791501

UK Spares Ltd
Unit 1155
Aztec West
Almondsbury
Bristol BS32 4TF
Tel: 01454 620500

Alternatively contact your
local supplying merchant
or wholesale branch or use
our online stockist finder at
www.interpartspares.co.uk

SPECIFICATION ADVICE HOTLINE

t | 01603 420220 e | specifier@heatraesadia.com

AFTER SALES SERVICE

t | 0344 871 1535 e | customer.support@heatraesadia.com

w | heatraesadia.com



OUR NATIONWIDE NETWORK OF CUSTOMER SUPPORT ENGINEERS

Heatrae Sadia has its very own dedicated nationwide network of highly trained customer support engineers so you can have peace of mind that we're always here to help.

PRODUCT RANGE

Full specification details on all our products are available to download from our website.

To support our corporate responsibility and sustainability charters and reduce our printed material we encourage you to download product brochures from our website.

In designing these files we have taken into account the need to access data on screen.

If you would like to receive a printed copy of our full product catalogue please call our literature hotline on 01603 420127.

Heatrae Sadia may introduce modifications to their products from time to time. Consequently, the details given in this brochure are subject to alteration without notice.

Please follow us online:



PN 36 00 6009 Issue 4

© Heatrae Sadia 2015