

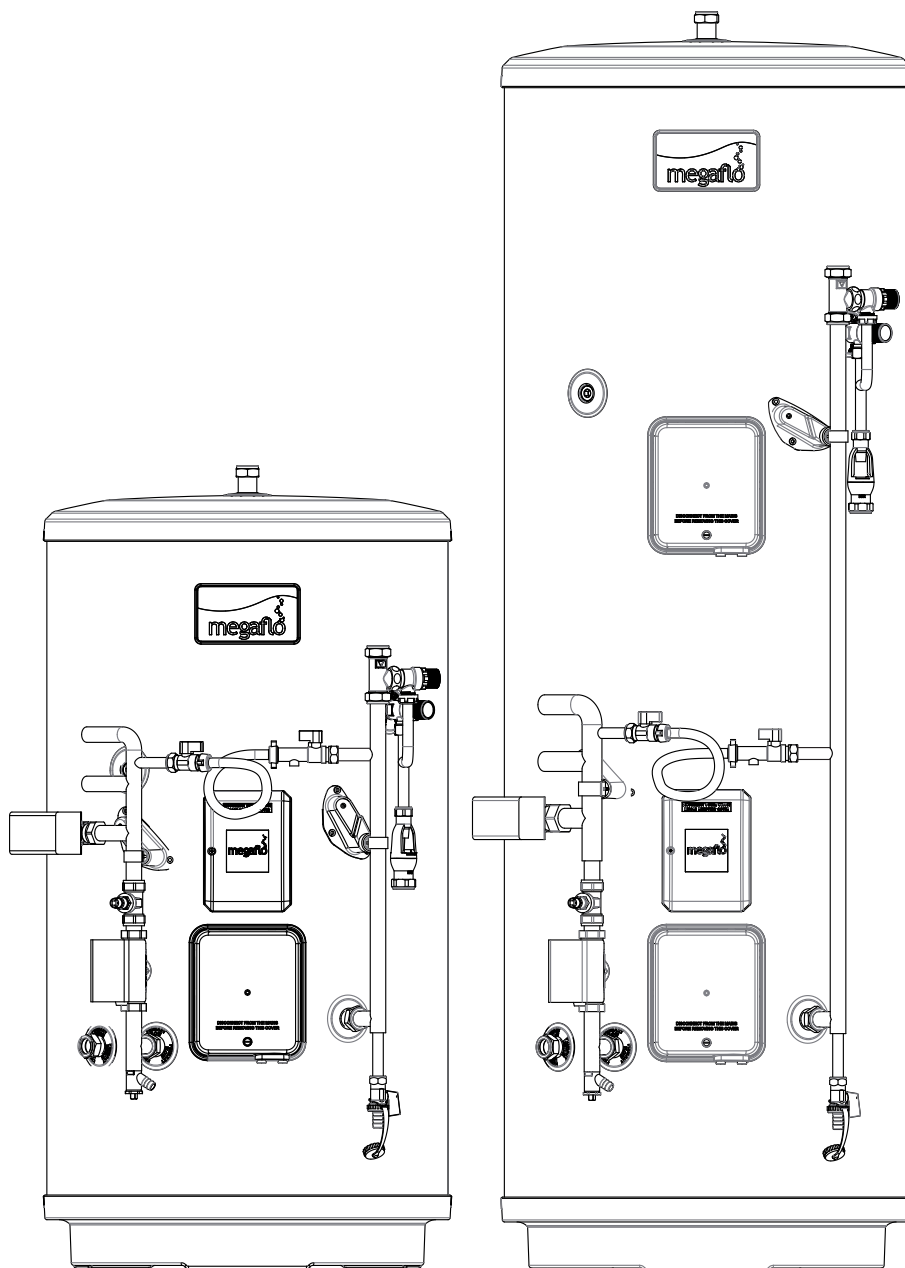

MEGAFLO Eco SystemReady Unvented Indirect Hot Water Cylinders



Contents

| | |
|--|---------|
| Product Specification | Page 3 |
| Installation and Commissioning Instrucions | Page 12 |
| Maintenance and Servicing..... | Page 27 |
| User Guide | Page 36 |



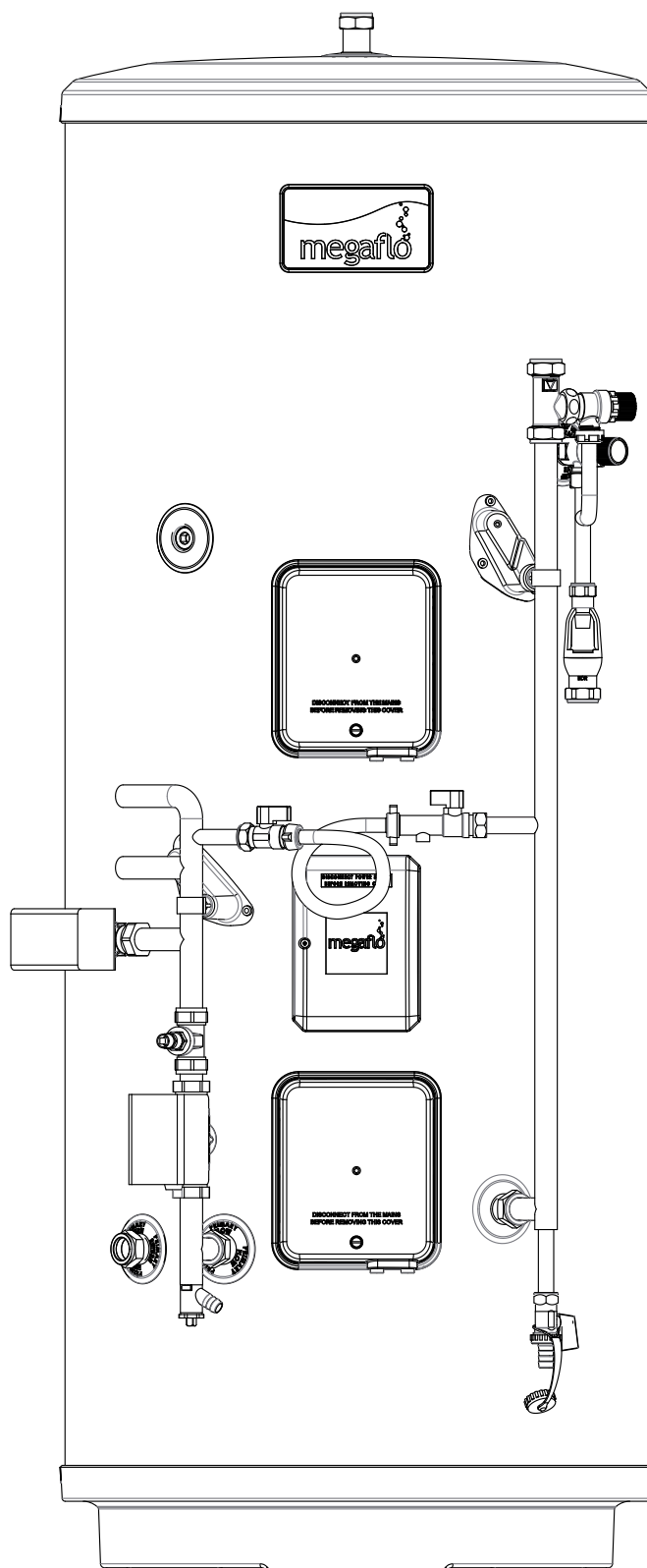

- Introduction
- Checklist
- General Requirements
- Water Supply
- Power Supply
- The Environment
- Specification and Dimensions



THE BENCHMARK™ SCHEME

Benchmark™ places responsibilities on both manufacturers and installers. The purpose is to ensure that customers are provided with the correct equipment for their needs, that it is installed, commissioned and serviced in accordance with the manufacturer's instructions by competent persons and that it meets the requirements of the appropriate Building Regulations. The Benchmark™ Checklist can be used to demonstrate compliance with Building Regulations and should be provided to the customer for future reference. Installers are required to carry out installation, commissioning and servicing work in accordance with the Benchmark™ Code of Practice which is available from the Heating and Hotwater Industry Council who manage and promote the scheme. Visit www.centralheating.co.uk for more information.

IMPORTANT NOTE TO USER: PLEASE REFER TO THE USER GUIDE SECTION ON PAGES 38 & 39 FOR IMPORTANT INFORMATION WITH RESPECT TO THE BENCHMARK SCHEME

Introduction

Congratulations on your purchase of a Megaflo eco SystemReady SB unvented water heater. The Megaflo eco SystemReady SB is a factory pre-plumbed and wired Megaflo eco unvented water heater. The Megaflo eco SystemReady SB is manufactured in the UK from top quality materials and meets all the latest relevant safety and constructional standards. The high grade Duplex stainless steel cylinder offers exceptional strength and corrosion resistance which is backed by a lifetime guarantee (see terms and conditions on page 40). Its performance, control system and insulation levels exceed the latest requirements of Building Regulation Part L.

The Megaflo eco SystemReady SB unvented water heater can be fed directly from the cold water mains supply to the property without the need for separate feed cisterns or vent pipes. It is supplied fitted with all its necessary inlet and safety controls for compliance with Building Regulations. Also fitted are a flow balancing valve, 2 x 2 port motorised valves and primary filling loop, a cylinder thermostat, thermal cut-out and wiring centre. The motorised valves and thermal controls are supplied pre-wired. A heating and domestic hot water programmer, room temperature sensor is supplied as an accessory for installation at a convenient position within the property. An electric immersion heater is also fitted to enable the unit to be heated should the boiler be turned off.

The Megaflo eco SystemReady SB primary circuit can be connected to a "system" boiler.

The Megaflo eco SystemReady SB requires no separate expansion vessel for the domestic hot water as any expanded water is accommodated within an internal air volume.

NOTE: If using a sealed heating system, adequate provision for expansion within the primary circuit MUST be provided by fitting the primary circuit expansion vessel supplied. Primary circuit expansion cannot be accommodated within the Megaflo eco SystemReady SB. Ensure the primary circuit expansion relief valve (supplied) is fitted to the primary circuit.

The safety valves fitted to the Megaflo eco SystemReady SB protect the water heater only. Failure to provide adequate primary system pressure relief when using a sealed heating system will invalidate the boiler manufacturer's warranty. Consult the boiler manufacturer's installation instructions for further advice.

System type boilers will usually have the primary circulation pump and primary expansion vessel fitted within the boiler itself.

Component Check List

Before commencing installation, check that all components for your Megaflo eco SystemReady SB unit are contained in the package. The following components are supplied:

Factory Fitted:

- Immersion heater(s) and thermal controls
- 8 Bar pressure relief valve (incorporating a check valve) (Figure 5) page 14
- Temperature / pressure relief valve (set at 90°C / 1 MPa (10bar))
- Tundish
- Indirect thermostat and thermal cut-out
- T&P relief valve insulation set
- Drain valve
- Wiring centre
- 2 x 2-Port motorised valve
- Lock-shield flow balancing valve
- Filling loop, straight
- Drain valve (with quarter turn lever)

* See Terms and Conditions of guarantee on page 39

Supplied loose:

- 3 Bar pressure reducing valve (incorporating strainer) (Figure 3) page 13
- Isolating valve (Figure 4) page 14
- Lifting handle
- Fixing template
- Automatic air vent

General Requirements

Important: Please read and understand this product guide before installing the Megaflo eco SystemReady SB water heater. Incorrect installation may invalidate the guarantee. This appliance can be used by children aged from 8 years and above and persons with reduced physical, sensory or mental capabilities or lack of experience and knowledge if they have been given supervision or instruction concerning use of the appliance in a safe way and understands the hazards involved. Children shall not play with the appliance, cleaning and user maintenance shall not be made by children without supervision. The Megaflo eco SystemReady SB must be Installed (Section 2), Commissioned (Section 2) and Maintained (Section 3) by a competent installer in accordance with Building Regulation G3 (England and Wales), Technical Standard P3 (Scotland) or Building Regulation P5 (Northern Ireland) and the Water Fitting Regulations (England and Wales) or Water Byelaws (Scotland). Following installation and commissioning, the operation of the heater should be explained to the user (Section 4) and this product guide left with them for future reference.

Storage and Handling

Please take care when handling a packaged Megaflo eco SystemReady SB. The unit is heavy and must only be moved manually within safe working practices. If the unit is to be stored before installation, it must be placed on a secure, level surface and in a dry, frost free environment.

Siting the Megaflo eco SystemReady SB (See Figure 1 below)

The Megaflo eco SystemReady SB unit must be vertically floor mounted. It can be placed anywhere convenient provided the discharge pipe(s) from its safety valves can be correctly installed. Areas that are subject to freezing must be avoided. Ensure that the floor is of sufficient strength to support the "full" weight of the unit (refer to Table 3 on page 9 for unit weights). Pipe runs should be kept as short as possible for maximum economy. Access to associated controls, immersion heaters and indirect controls should be possible for servicing and maintenance of the system.

Please do not install valves or pipework (except discharge pipe) within 50mm (2") of the T&P relief valve to allow your insulation set to be fitted. The insulation set is important to ensure heat and energy conservation. See section 2 (page 17) for more information.

To aid installation, the Megaflo eco SystemReady SB is provided with lifting points located in the base moulding and a lifting handle. The lifting handle should be fully threaded onto the outlet boss before use. Once the Megaflo eco SystemReady SB is suitably positioned the lifting handle should be removed to allow connection of the outlet pipework. The weight of the units are noted on Table 3, page 9.

If you choose to install the Megaflo eco SystemReady SB in the highest point in the property (e.g. loft space), it is advisable to install an additional automatic air vent (AAV) (available as a spare, part number 95 605 050) above the pump to enable air to be removed from the system. The addition of the AAV is not required if siting the cylinder in a lower position.

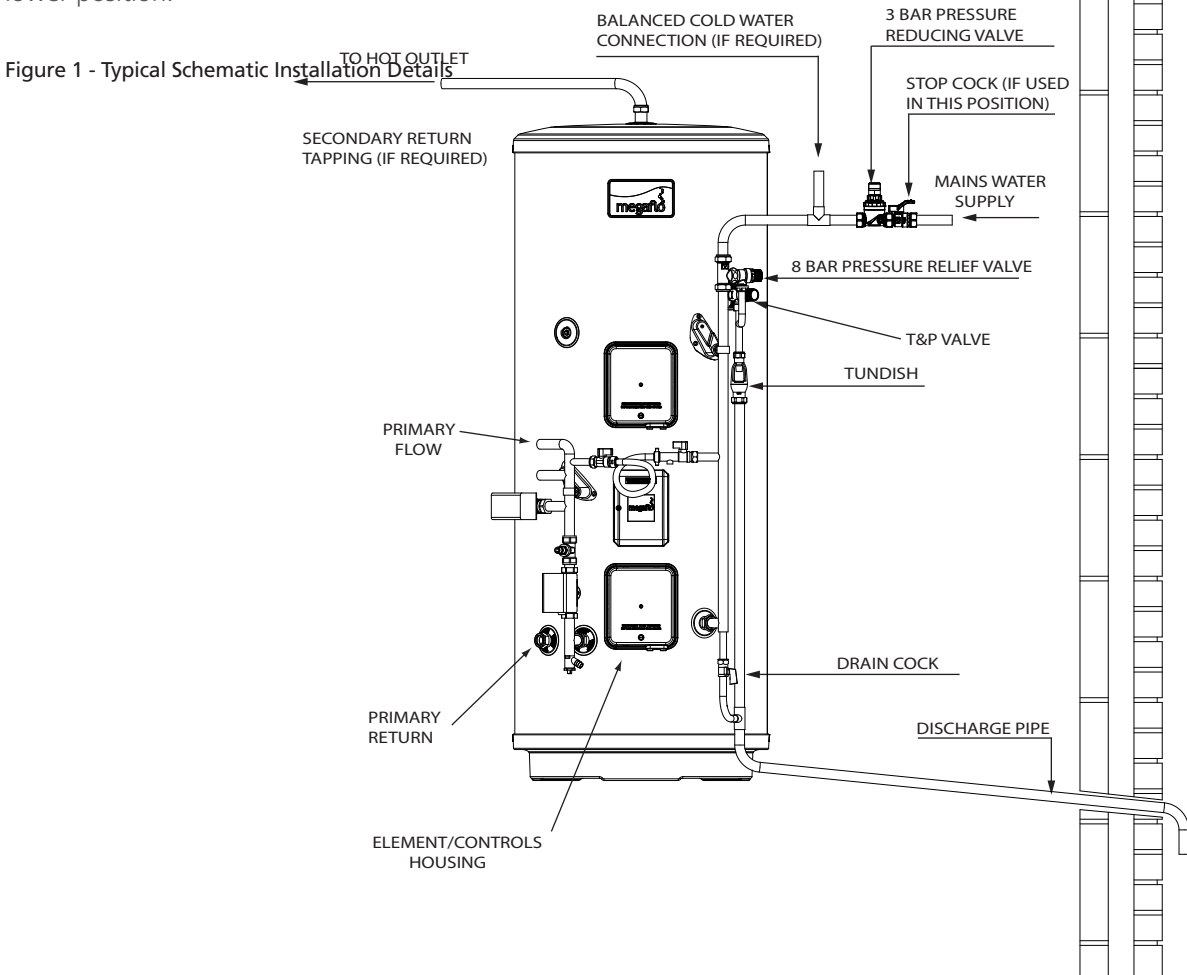

Outlet / Terminal Fittings (Taps, Etc.)

The Megaflo eco SystemReady SB can be used in conjunction with most types of terminal fittings. It is advantageous in many mixer showers to have balanced hot and cold water supplies, in these instances the balanced cold water supply should be teed off the supply to the Megaflo eco SystemReady SB immediately after the 3 bar pressure reducing valve (See Figure 6, page 15). Branches to cold drinking outlets should be taken before the valve.

Outlets situated higher than the Megaflo eco SystemReady SB unit will give outlet pressures lower than that at the heater, a 10m height difference will result in a 0.1 MPa (1 bar) pressure reduction at the outlet fitting.

NOTE: Accessories should have a rated operating pressure of at least 0.8 MPa (8 bar).

Limitations

The Megaflo eco SystemReady SB unvented water heater should not be used in any of the following instances:

- Solid fuel boilers or any other boiler in which the energy input is not under effective thermostatic control unless additional and appropriate safety measures are installed.
- Gravity circulation primaries.
- Steam heating plant unless additional and appropriate safety devices are installed.
- Ascending spray type bidets or any other Class 5 back syphonage risk requiring that a Type AA, AB, AD or AG air gap be employed.
- Water supplies that have either inadequate pressure or where the supply may be intermittent.
- Situations where it is not possible to safely pipe away any discharge from the safety valves.
- Areas where the water consistently contains a high proportion of solids, e.g. suspended matter that could block the strainer, unless adequate filtration can be ensured.
- The water supply must be of wholesome water quality (Fluid Category 1 as defined by the Water Supply Regulations 1999)
- The installation must be carried out in accordance with the relevant requirements of:
 - The appropriate Building Regulations: Either The Building Regulations (England), The Building Regulations (Scotland) or Building Regulations (Northern Ireland).
 - The Water Fittings Regulations (England and Wales) or Water Byelaws (Scotland).

Water Supply

Bear in mind that the mains water supply to the property will be supplying both the hot and cold water requirements simultaneously. It is recommended that the maximum water demand be assessed and the water supply checked to ensure this demand can be met.

NOTE: A high mains water pressure will not always guarantee high flow rates.

Wherever possible the main supply pipe should be in 22mm. The minimum mains water supply requirements should be 0.15 MPa (1.5 bar) working pressure and 20 litres per minute flowrate.

At these values outlet flowrates may be poor if several outlets are used simultaneously, the higher the available pressure and flowrate the better the system performance will be.

The Megaflo eco SystemReady SB has an operating pressure of 3 bar which is controlled by the 3 bar pressure reducing valve. The 3 Bar pressure reducing valve can be connected to a maximum mains supply pressure of 1.6 MPa (16 bar).

The Megaflo eco SystemReady SB is to be used for the storage of wholesome water (max. 250mg/l chloride).

Warning: Do not switch on if there is a possibility that the water in the heater is frozen.

Electrical Supply

WARNING: THIS APPLIANCE MUST BE EARTHED. IT IS SUITABLE FOR A.C. SUPPLY ONLY. ELECTRICAL INSTALLATION MUST BE CARRIED OUT BY A COMPETENT ELECTRICIAN AND BE IN ACCORDANCE WITH THE LATEST I.E.E. WIRING REGULATIONS.

ENSURE THE ELECTRICAL SUPPLY IS SWITCHED OFF BEFORE MAKING ANY CONNECTIONS TO THE MEGAFLO ECO SystemReady SB

The Environment

This product is made from many recyclable materials, therefore at the end of its useful life it should be disposed of at a Local Authority Recycling Centre in order to realise the full environmental benefits. Insulation is by means of an approved HCFC/CFC free polyurethane foam.

Specifications and Dimensions

Outline Specifications

| | |
|--|--------------------------------------|
| Maximum mains water supply pressure (to 3 bar pressure reducing valve) | 1.6 MPa (16 bar) |
| Operating pressure (pressure reducing valve set pressure – non adjustable) | 0.3 MPa (3 bar) |
| Expansion relief valve set pressure | 0.8 MPa (8 bar) |
| Temperature / pressure relief valve set temp / pressure | 90°C / 1MPa (10 bar) |
| Immersion heater rating (a.c. supply only) | 3kW @ 240V 50Hz 2.8kW @ 230V 50Hz |

Outer casing:

White textured plastic coated corrosion resistant steel

Water container:

Duplex stainless steel. 100% pressure tested to 1.5 MPa (15 bar).

Thermal insulation:

CFC/HCFC free fire retardant expanded polyurethane foam with zero ozone depletion potential. It has a Global Warming Potential (GWP) of 3.1. Nominal thickness 60mm.

Pipe connections:

All connections accept 22mm outside diameter pipe – compression nuts and olives supplied. Thread rate is 3/4" BSP male parallel to accept standard 3/4" BSP female fittings if required.

Safety features:

Manually resettable thermal cut-out on heating element

Manually resettable thermal cut-out for primary heating. Is wired in conjunction with 2-port motorised valve supplied

Factory fitted temperature / pressure relief valve

The pace of product development is such that we reserve the right to change product specifications without notice. We do, however, strive to ensure that all information in this product guide is accurate at the time of publication.

Table 1 - Standing Heat-loss

| NOMINAL CAPACITY (LITRES) | STANDING HEAT LOSS | |
|---------------------------|--------------------|--------------------|
| | PER DAY (kWh/24h) | PER YEAR (kWh/24h) |
| 125 | 1.05 | 383.3 |
| 145 | 1.18 | 430.7 |
| 170 | 1.20 | 438.0 |
| 210 | 1.42 | 518.3 |
| 250 | 1.61 | 587.7 |
| 300 | 1.69 | 616.9 |

Table 2 - Dimensions

| SIZE | TYPE | DIMENSIONS (mm) | | | | | |
|------|----------|-----------------|-----|------|------|------|-----|
| | INDIRECT | A | B | C | D | E | F |
| 125L | SB | 316 | 355 | 794 | 1102 | 709 | N/A |
| 145L | SB | 316 | 355 | 895 | 1229 | 810 | N/A |
| 170L | SB | 316 | 355 | 1020 | 1384 | 934 | N/A |
| 210L | SB | 316 | 355 | 1095 | 1486 | 1011 | * |
| 250L | SB | 316 | 355 | 1323 | 1738 | 1238 | * |
| 300L | SB | 316 | 355 | 1574 | 2053 | 1526 | * |

* A SECOND ELEMENT KIT CAN BE PURCHASED, KIT NO 95970554

Figure 2 - Megaflo eco SystemReady Indirect

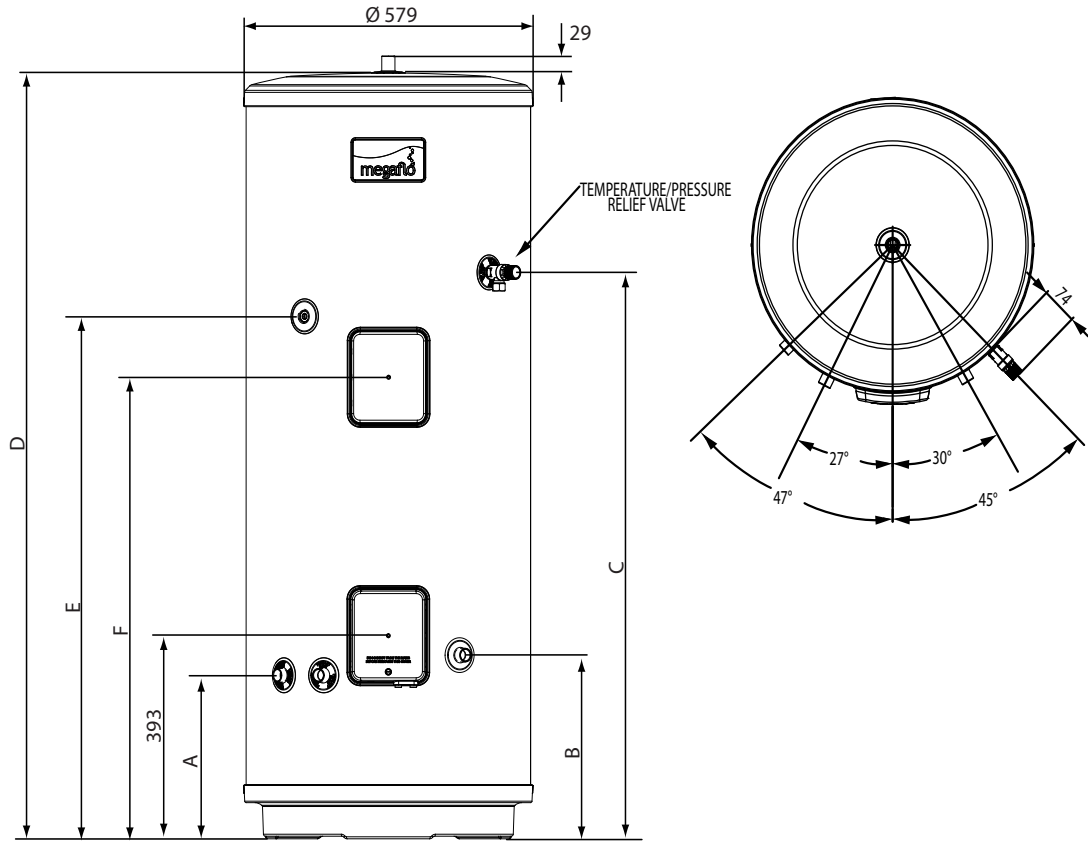

Dimensions (Plan View)

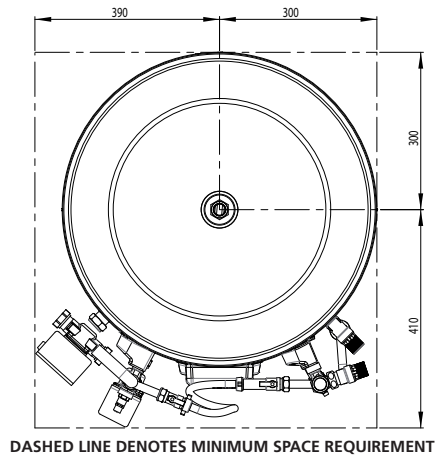

| Indirect | | | | | | |
|----------------------------|-------|-------|-------|-------|-------|-------|
| Model(s) | 125 | 145 | 170 | 210 | 250 | 300 |
| Energy efficiency class | B | B | B | B | C | C |
| Storage volume V in litres | 125.0 | 145.0 | 170.0 | 210.0 | 250.0 | 300.0 |
| Standing loss in W | 50.0 | 55.0 | 59.0 | 65.0 | 70.0 | 79.0 |

Table: Technical parameters in accordance with European Commission regulations 814/2013 and 812/2013

Table 3 - Technical Specification

| SIZE | UNIT WEIGHT (kg) | | COIL SPECIFICATIONS | | | |
|------|------------------|------|---------------------|----------------|-----------------|-------------|
| | EMPTY | FULL | SURFACE (SQ/M) | HEAT-UP (MINS) | RECOVERY (MINS) | RATING (kW) |
| 125L | 39 | 179 | 0.58 | 23 | 15 | 18.3 |
| 145L | 44 | 199 | 0.72 | 24 | 17 | 18.7 |
| 170L | 48 | 230 | 0.79 | 22 | 16 | 24.3 |
| 210L | 51 | 250 | 0.79 | 28 | 19 | 24.3 |
| 250L | 57 | 293 | 0.79 | 34 | 23 | 23.9 |
| 300L | 65 | 348 | 0.79 | 39 | 27 | 24.5 |

NOTE

Coil heating performance based on a primary flow rate of 15L/min at 80°C.
 Temperature rise is from 15°C to 60°C.

Honeywell 2 Port Motorised Valves:

Model No.: V4043H
 Voltage rating: 230V ac, 50HZ
 Power consumption: 6W
 Primary water temperature range: 5 to 88°C
 Maximum ambient temperature: 52°C

NOTES.

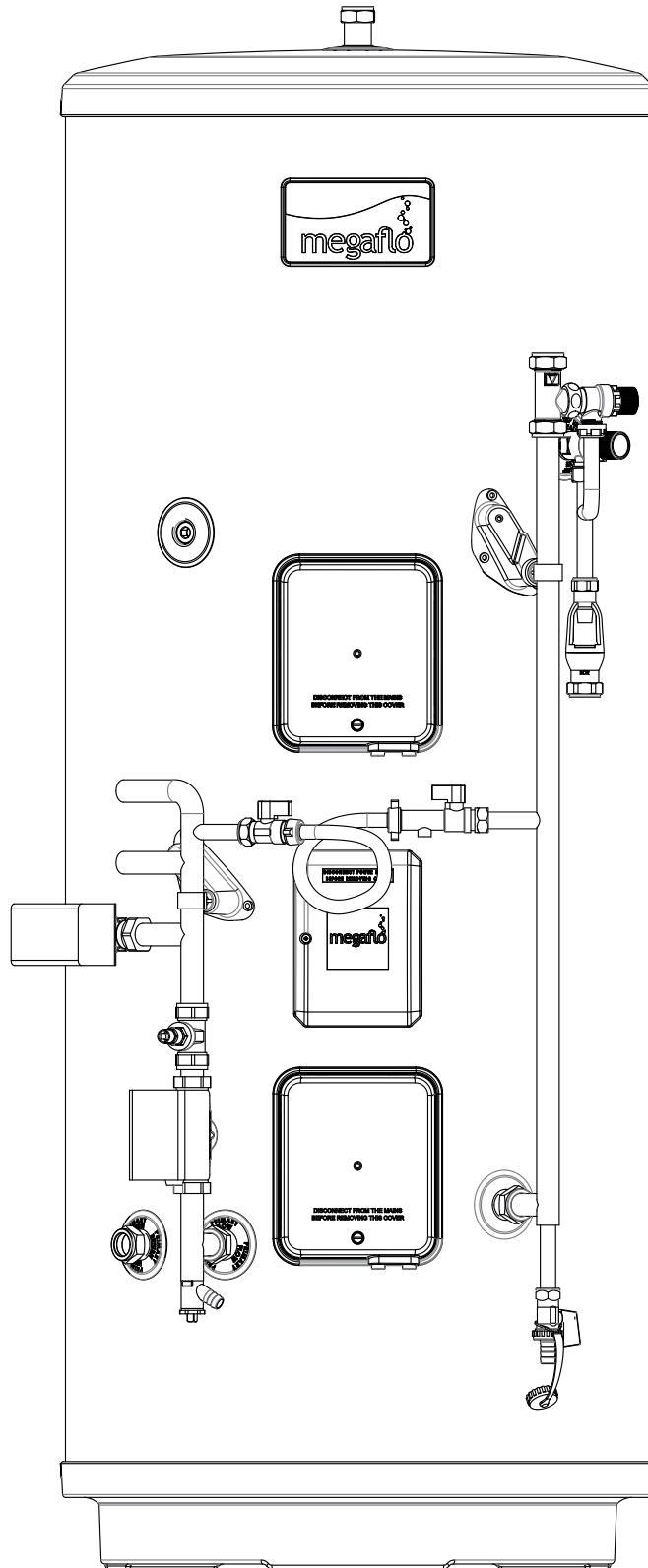

- General Installation
- Commissioning

General Installation

Pipe Fittings

The connection points to the heating system are in 22mm o/dia copper pipe on 125/145/170 and 210 litre units. On units 250 litres and above the primary flow connection is 28mm, the flow connections to central heating (CH) zones 22mm and the domestic hot water (DHW) return connection 22mm o/dia copper pipe. The use of appropriately sized COMPRESSION FITTINGS is recommended when connecting to the Megaflo eco SystemReady pipes. Solder fittings can be used, but extreme care must be taken to ensure the plastic coating of the unit casing is not damaged by heat. Push fit type fittings can be used for connection to the copper pipes. The inlet connection to the 3 bar pressure reducing valve is 22mm compression. The Megaflo eco SystemReady SB outlet fitting is suitable for connection to 22mm o/dia pipe (compression nut and olive supplied). The outlet is also threaded 3/4" BSP male parallel should threaded pipe connections be preferred.

Cold Water Supply

A 22mm cold water supply is recommended, however, if a 15mm (1/2") supply exists which provides sufficient flow (see Section 1, page 7 "Water Supply") this may be used. More flow noise may be experienced from small bore pipes due to the increased water velocity through them.

The 3 bar pressure reducing valve supplied must be fitted with the Megaflo eco SystemReady SB incorporates a full flow isolating valve (separate part, See Figure 4, page 14) which will enable the Megaflo eco SystemReady SB to be isolated from the mains supply for maintenance or servicing. To close the valve the blue handle should be turned so that it lies at 90° to the direction of flow. To open, turn the handle so that it lies parallel to the direction of flow.

3 Bar Pressure Reducing Valve (See Figure 3 below)

The 3 bar pressure reducing valve can be connected anywhere on the cold water mains supply prior to the Megaflo eco SystemReady SB unit. There is no requirement to site it close to the unit, it can be located at a point where the mains supply enters the premises if this is more convenient but you must install a non-return valve just after the reducing valve for ease of maintenance.

The 3 bar pressure reducing valve can be installed as a complete one-piece unit or incorporating the isolation valve (see Fig 4, page 14). The valve incorporates a factory set, non-adjustable pressure reducer / strainer. The valve can be fitted in any orientation to suit the installation, however, ensure that the valve is installed with the direction of flow arrows (stamped on the side of the brass body) pointing towards the Megaflo eco SystemReady SB heater.

If a balanced pressure cold water supply is required to a thermostatic shower mixer valve this may be teed off the supply to the Megaflo eco SystemReady SB immediately after the 3 bar pressure reducing valve (See Figure 6, page 15).

Figure 3 - 3 Bar Pressure Reducing Valve

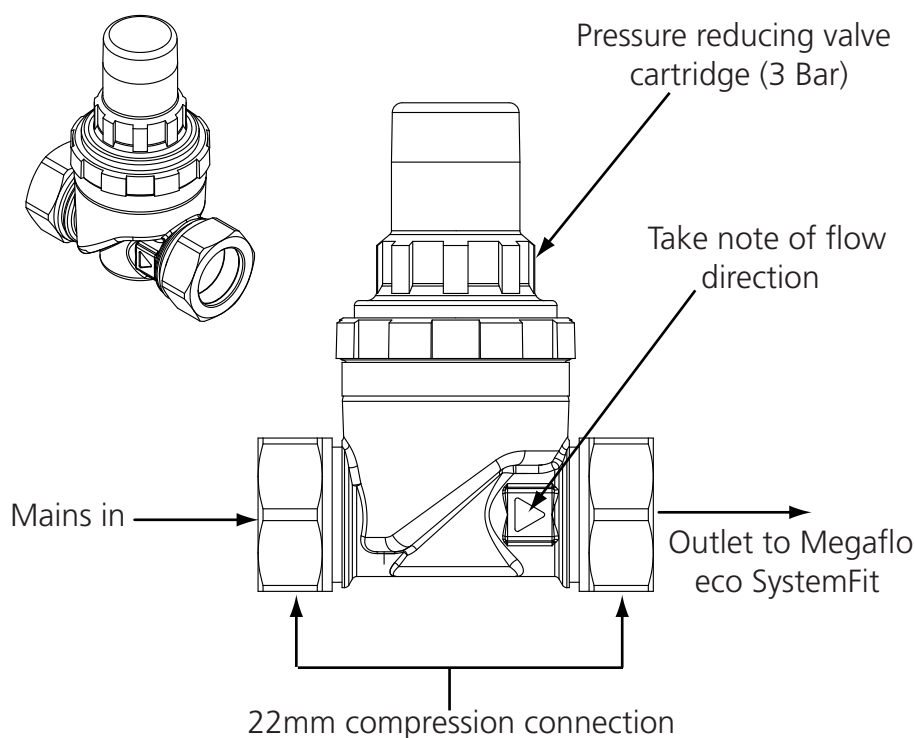

8 bar pressure relief valve (See Figure 5 below)

Should a balanced pressure cold water draw off supply be required for the cold water outlets, this should be taken off between the 3 bar pressure reducing valve and 8 bar pressure relief valve (see Figure 6, page 15). **Branches to drinking water outlets should be taken before the valve to avoid the possibility of warm expanded water being drawn from the tap.**

Figure 4 - 3 Bar Pressure Reducing Valve with Stopcock

Isolating valve is grouped with the 3 Bar pressure Reducing valve. Make sure the flow is correct to the markings on the valve.

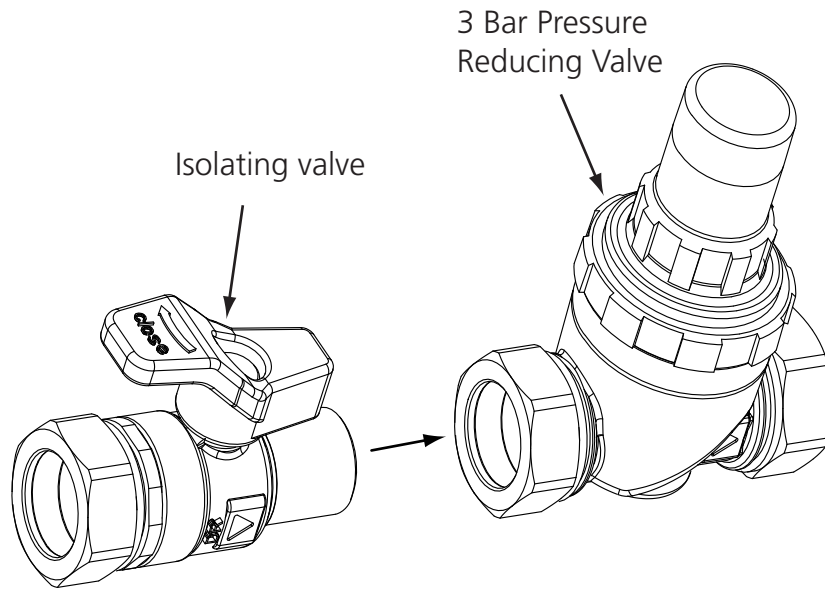

Figure 5 - 8 Bar Pressure Relief Valve

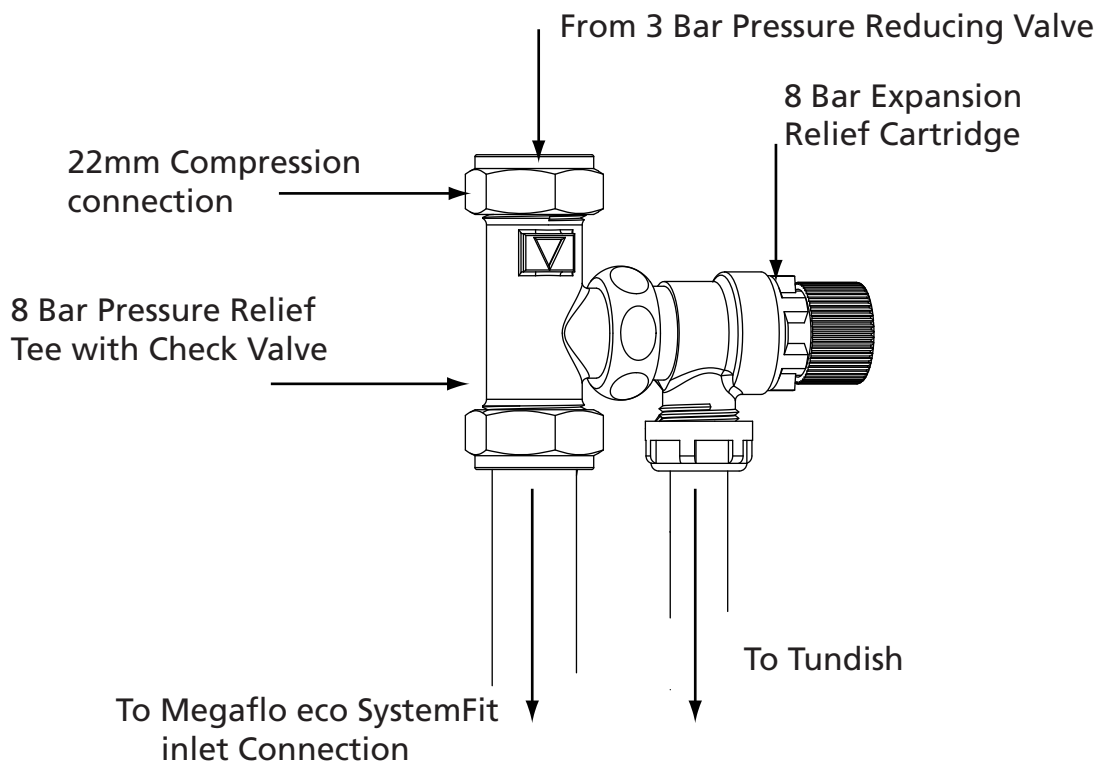
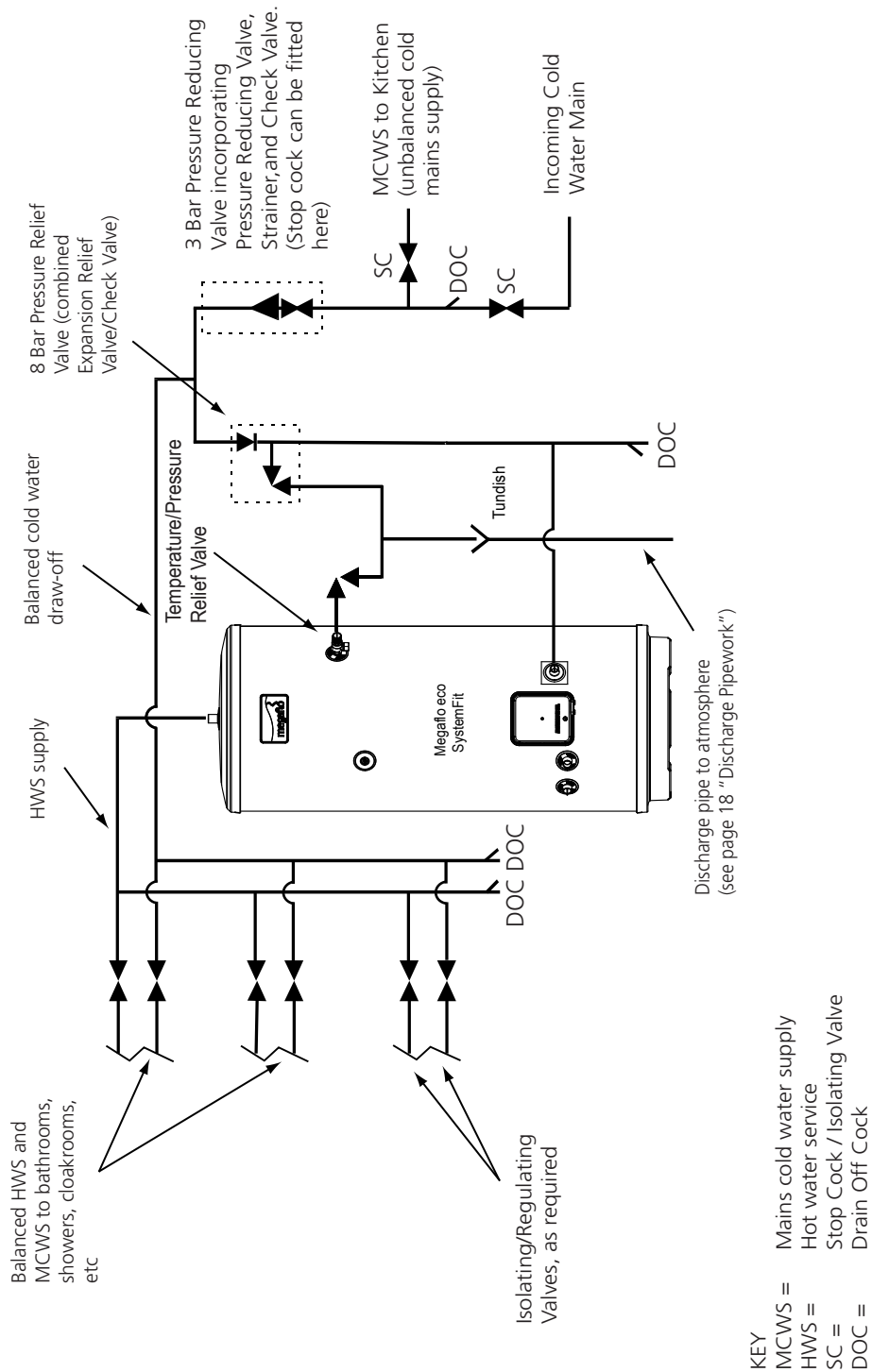

Figure 6 - Schematic installation diagram using 3 Bar Pressure Reducing Valve in conjunction with 8 Bar Pressure Relief Valve



Drain Taps

Drain taps are fitted to both the primary system pipework and the cold water inlet to facilitate draining the unit or indirect heating heating circuit for maintenance purposes. It is recommended that the outlet point of the drain pipe work be at least 1 metre below the level of the heater (this can be achieved by attaching a hose pipe to the drain tap outlet spigot).

Outlet Pipework

Ideally the pipework from the Megaflo eco SystemReady SB to the outlet fittings should be in 22mm pipe with short runs of 15mm pipe to showers and basin taps. Small bore pipe can also be used to suit some taps, but runs should be of minimum length. Pipe sizes may vary due to system design.

Secondary Circulation

If a secondary circulation system is required it is recommended that it be connected to the Megaflo eco SystemReady SB as shown in Figure 7 below. The secondary return pipe should be in 15mm pipe and incorporate a check valve to prevent backflow. A suitable WRAS approved bronze circulation pump will be required. On large systems, due to the increase in system water content, it may be necessary to fit additional expansion volume to the system by fitting an external expansion vessel to the secondary circuit. This should be done if the capacity of the secondary circuit exceeds 10 litres.

Pipe Capacities (copper)

15mm o/d = 0.13 litres per metre run (10 litres = 77m)

22mm o/d = 0.38 litres per metre run (10 litres = 26m)

28mm o/d = 0.55 litres per metre run (10 litres = 18m)

Figure 7 - Secondary Circulation Connection

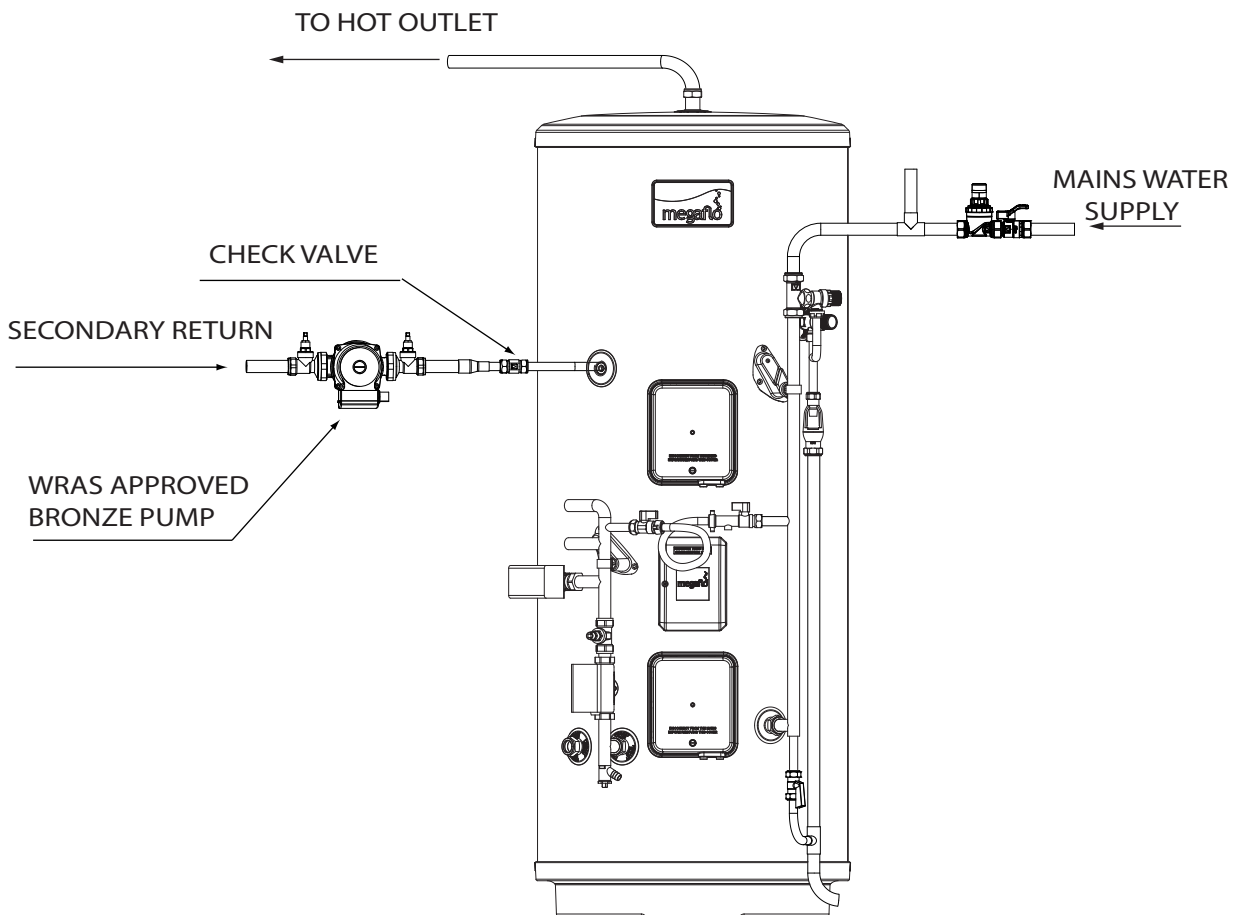

T&P Relief Valve Insulation

A set of insulating components is supplied with the Megaflo eco SystemReady SB water heater and should be installed to gain maximum heat and energy saving benefits. See Figure 8 below, for installation instructions.

Warnings

- i) Under no circumstances should the factory fitted temperature / pressure relief valve be removed other than by authorised heateam personnel. To do so will invalidate any guarantee or claim.
- ii) The 3 bar pressure reducing valve must be fitted to the mains water supply to the Megaflo eco SystemReady SB unit.
- iii) No control or safety valves should be tampered with or used for any other purposes.
- iv) Water may drip from the discharge pipe of the 8 bar pressure relief valve (expansion valve) and this pipe must be left open to atmosphere. The discharge pipe should not be blocked or used for any other purpose.
- v) The tundish must be installed so that it is visible to the end user.
- vi) The tundish, drain valve and motorised valves must be installed away from any electrical components.
- vii) No valve should be fitted between the 8 bar pressure relief valve and the Megaflo eco SystemReady SB unit.

Figure 8 - Installation of T&P Insulation Set

IMPORTANT INFORMATION: HOW TO INSULATE YOUR T&P RELIEF VALVE

TO SAVE HEAT AND ENERGY A SET OF INSULATING PARTS FOR THE T&P RELIEF VALVE HAVE BEEN SUPPLIED WITH THIS WATER HEATER. INSTALL THE HEATER FIRST THEN FIT THE INSULATING PARTS BY FOLLOWING THE DIAGRAMS BELOW.

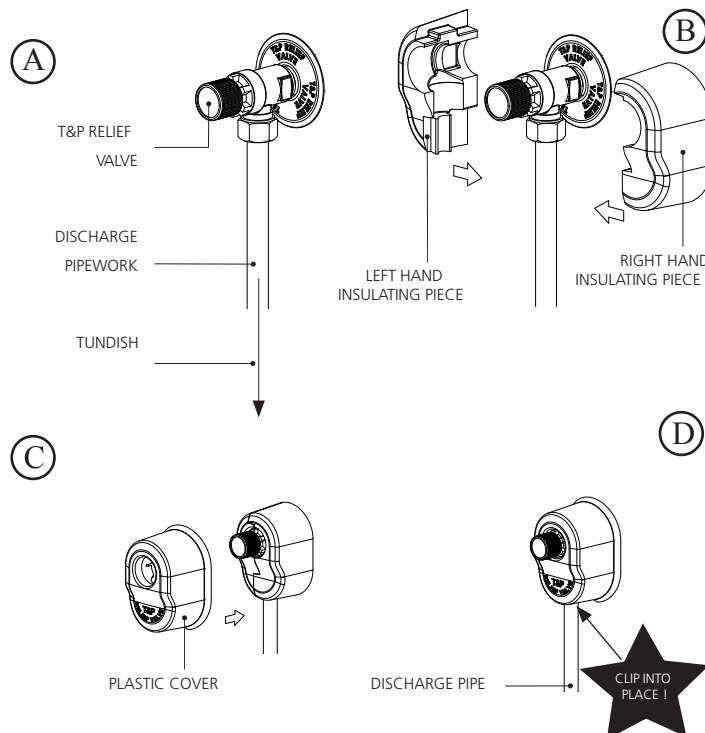

The following extract is taken from the latest G3 Regulations

Discharge pipes from safety devices

Discharge pipe D1

- 3.50 Safety devices such as **temperature relief valves** or **combined temperature and pressure** and **pressure relief valves** (see paragraphs 3.13 or 3.18) should discharge either directly or by way of a manifold via a short length of metal pipe (D1) to a **tundish**.
- 3.51 The diameter of discharge pipe (D1) should be not less than the nominal outlet size of the **temperature relief valve**.
- 3.52 Where a manifold is used it should be sized to accept and discharge the total discharge from the discharge pipes connected to it.
- 3.53 Where valves other than the **temperature and pressure relief valve** from a single unvented hot water system discharge by way of the same manifold that is used by the safety devices, the manifold should be factory fitted as part of the **hot water storage system unit** or package.

Tundish

- 3.54 The **tundish** should be vertical, located in the same space as the unvented **hot water storage system** and be fitted as close as possible to, and lower than, the valve, with no more than 600mm of pipe between the valve outlet and the **tundish** (see Figure 9).

Note: To comply with the Water Supply (Water Fittings) Regulations, the **tundish** should incorporate a suitable air gap.

- 3.55 Any discharge should be visible at the **tundish**. In addition, where discharges from safety devices may not be apparent, e.g. in dwellings occupied by people with impaired vision or mobility, consideration should be given to the installation of a suitable safety device to warn when discharge takes place, e.g. electronically operated.

Discharge pipe D2

- 3.56 The discharge pipe (D2) from the **tundish** should:
- (a) have a vertical section of pipe at least 300mm long below the **tundish** before any elbows or bends in the pipework (see Figure 9); and
 - (b) be installed with a continuous fall thereafter of at least 1 in 200.
- 3.57 The discharge pipe (D2) should be made of:
- (a) metal; or
 - (b) other material that has been demonstrated to be capable of safely withstanding temperatures of the water discharged and is clearly and permanently marked to identify the product and performance standard (e.g. as specified in the relevant part of BS 7291).
- 3.58 The discharge pipe (D2) should be at least one pipe size larger than the nominal outlet size of the safety device unless its total equivalent hydraulic resistance exceeds that of a straight pipe 9m long, i.e. for discharge pipes between 9m and 18m the equivalent resistance length should be at least two sizes larger than the nominal outlet size of the safety device; between 18 and 27m at least 3 sizes larger, and so on; bends must be taken into account in calculating the flow resistance. See Diagram 1, Table 1 and the worked example.

Note: An alternative approach for sizing discharge pipes would be to follow Annex D, section D.2 of BS 6700:2006 Specification for design, installation, testing and maintenance of services supplying water for domestic use within buildings and their curtilages.

- 3.59 Where a single common discharge pipe serves more than one system, it should be at least one pipe size larger than the largest individual discharge pipe (D2) to be connected.
- 3.60 The discharge pipe should not be connected to a soil discharge stack unless it can be demonstrated that that the soil discharge stack is capable of safely withstanding temperatures of the water discharged, in which case, it should:
- (a) contain a mechanical seal, not incorporating a water trap, which allows water into the branch pipe without allowing foul air from the drain to be ventilated through the **tundish**;
 - (b) be a separate branch pipe with no **sanitary appliances** connected to it;
 - (c) if plastic pipes are used as branch pipes carrying discharge from a safety device they should be either polybutalene (PB) to Class S of BS 7291-2:2006 or cross linked polyethylene (PE-X) to Class S of BS 7291-3:2006; and
 - (d) be continuously marked with a warning that no **sanitary appliances** should be connected to the pipe.

Note:

1. Plastic pipes should be joined and assembled with fittings appropriate to the circumstances in which they are used as set out in BS EN ISO 1043-1.
2. Where pipes cannot be connected to the stack it may be possible to route a dedicated pipe alongside or in close proximity to the discharge stack.

Termination of discharge pipe

- 3.61 The discharge pipe (D2) from the **tundish** should terminate in a safe place where there is no risk to persons in the vicinity of the discharge.
- 3.62 Examples of acceptable discharge arrangements are:
- b) to a trapped gully with the end of the pipe below a fixed grating and above the water seal;
 - (c) downward discharges at low level; i.e. up to 100mm above external surfaces such as car parks, hard standings, grassed areas etc. are acceptable providing that a wire cage or similar guard is positioned to prevent contact, whilst maintaining visibility; and
 - (d) discharges at high level: e.g. into a metal hopper and metal downpipe with the end of the discharge pipe clearly visible or onto a roof capable of withstanding high temperature discharges of water and 3m from any plastic guttering system that would collect such discharges.
- 3.63 The discharge would consist of high temperature water and steam. Asphalt, roofing felt and non-metallic rainwater goods may be damaged by such discharges.

Discharge Pipework

It is a requirement of Building Regulations that any discharge from an unvented system is conveyed to where it is visible, but will not cause danger to persons in or about the building. The tundish and discharge pipes should be fitted in accordance with the requirements and guidance notes of Building Regulations. Building Regulation G3 Requirements and Guidance section 2 (page 18) are reproduced in the following sections.

For discharge pipe arrangements not covered by G3 Guidance advice should be sought from your local Building Control Officer. Any discharge pipe connected to the pressure relief devices (Expansion Valve and Temperature / Pressure Relief Valve) must be installed in a continuously downward direction and in a frost free environment.

The water may drip from the discharge pipe of the pressure relief device and that this pipe must be left open to the atmosphere. The pressure relief device is to be operated regularly to remove lime deposits and to verify that it is not blocked.

G3 Requirement

"...there shall be precautions...to ensure that the hot water discharged from safety devices is safely conveyed to where it is visible but will not cause danger to persons in or about the building".

Notes:

- 1) Discharge pipe-work D2 can now be a plastic pipe but only pipes that have been tested to a minimum 110°C must be used.
- 2) Discharge pipe D2 can now be plumbed in the soil stack but only soil stacks that can handle temperatures of 99°C or greater should be used.

Table 4 Sizing of copper discharge pipe "D2" for common T&P Relief Valve sizes.

| VALVE OUTLET SIZE | MINIMUM SIZE OF DISCHARGE PIPE D1 | MINIMUM SIZE OF DISCHARGE PIPE D2 FROM TUNDISH | MAXIMUM RESISTANCE ALLOWED, EXPRESSED AS A LENGTH OF STRAIGHT PIPE (I.E. NO ELBOWS OR BENDS) | RESISTANCE CREATED BY EACH ELBOW OR BEND |
|-------------------|-----------------------------------|--|--|--|
| G 1/2 | 15mm | 22mm 28mm 35mm | UP TO 9m UP TO 18m UP TO 27m | 0.8m 1.0m 1.4m |
| G 3/4 | 22mm | 28mm 35mm 42mm | UP TO 9m UP TO 18m UP TO 27m | 1.0m 1.4m 1.7m |
| G 1 | 28mm | 35mm 42mm 54mm | UP TO 9m UP TO 18m UP TO 27m | 1.4m 1.7m 2.3m |

Figure 9 - Schematic discharge pipe arrangement

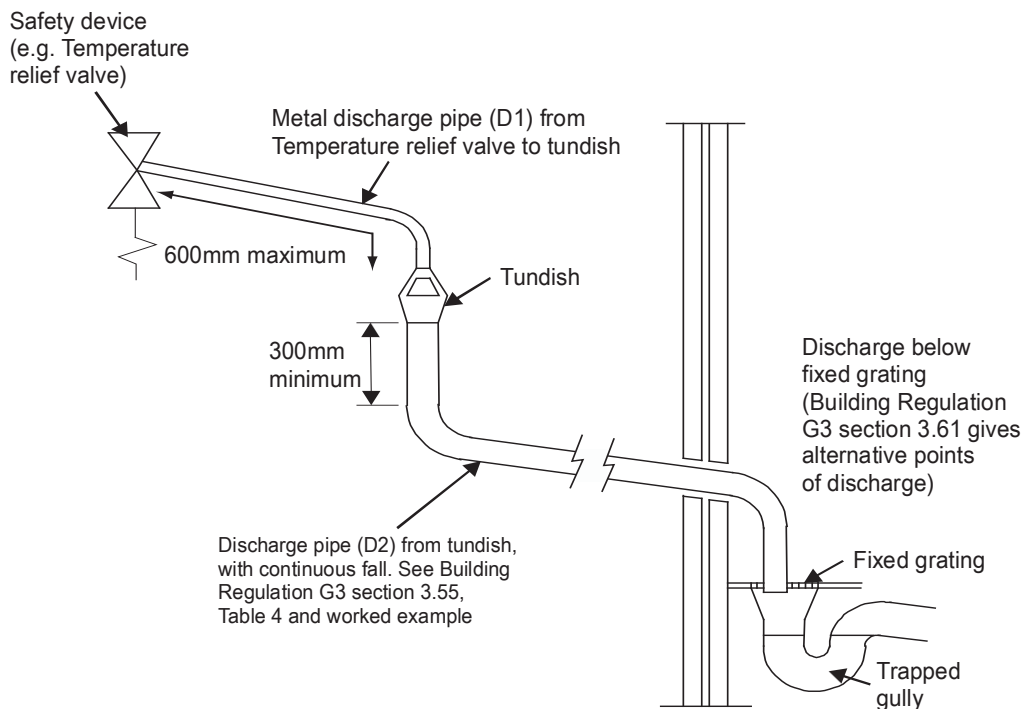

Worked example of discharge pipe sizing

The example on page 19 is for a G $\frac{1}{2}$ temperature relief valve with a discharge pipe (D2) having 4 No. elbows and length of 7m from the tundish to the point of discharge.

From Table 4:

Maximum resistance allowed for a straight length of 22mm copper discharge pipe (D2) from a G $\frac{1}{2}$ temperature relief valve is 9m.

Subtract the resistance for 4 No. 22mm elbows at 0.8m each = 3.2m

Therefore the permitted length equates to: 5.8m

5.8m is less than the actual length of 7m therefore calculate the next largest size.

Maximum resistance allowed for a straight length of 28mm pipe (D2) from a G $\frac{1}{2}$ temperature relief valve equates to 18m.

Subtract the resistance of 4 No. 28mm elbows at 1m each = 4m

Therefore the maximum permitted length equates to: 14m

As the actual length is 7m, a 28mm (D2) copper pipe will be satisfactory.

Installation-Primary Circuit

Boiler Selection

The Megaflo eco SystemReady SB to be used with a System Boiler.

Indirect Thermal Cut-Out And 2-Port Motorised Valve

To comply with Building Regulations, and to prevent the Megaflo eco SystemReady SB from overheating the 2-port motorised valve supplied MUST be fitted to the primary flow to the indirect coil. This valve is factory wired in series with the indirect thermal cut-out such that the primary flow to the heating coil is interrupted should the Megaflo eco SystemReady SB unit overheat.

Figure 10 - Primary connections to SystemReady units

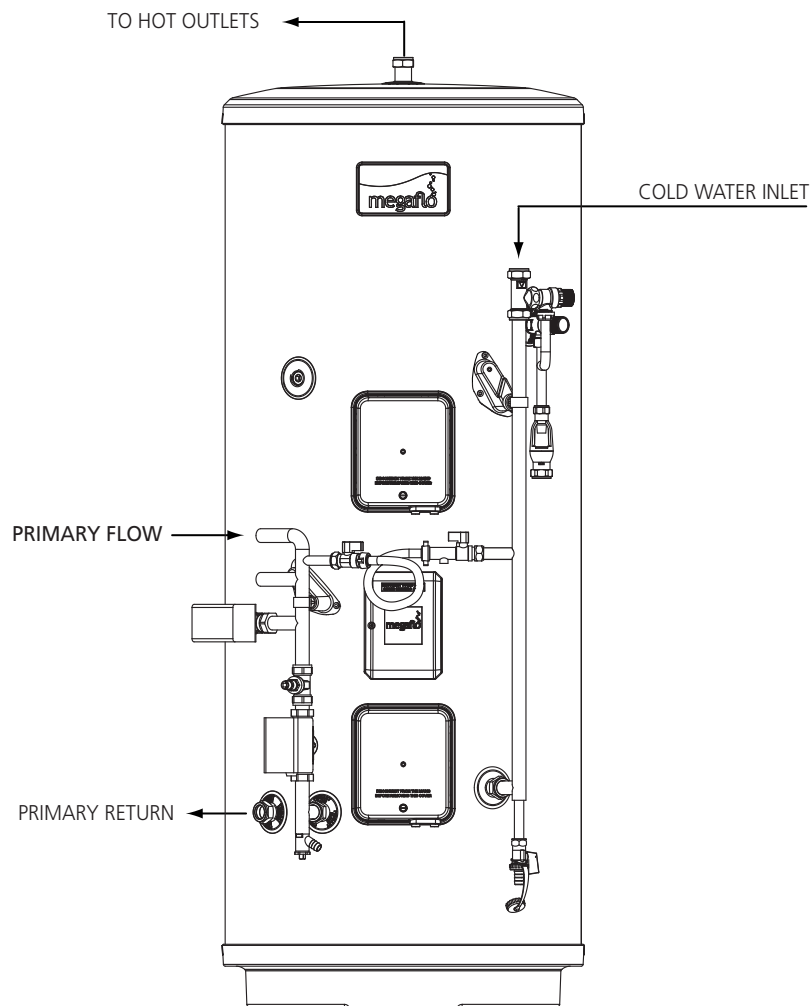

Wiring

All electrical wiring should be carried out by a competent electrician and be in accordance with the latest I.E.E. Wiring Regulations.

The Megaflo eco SystemReady SB combined thermostat and thermal cut-out and motorised valves are factory pre-wired. Further wiring will be required between the wiring centre, the programmer, room temperature sensor and the boiler (see Figure 13, page 23). Additional controls and wiring will be required if a second CH zone is to be fitted to the installation. **The indirect thermal cut-out MUST NOT be bypassed.**

Heating System Controls

The controls provided with the Megaflo eco SystemReady SB will ensure the safe operation of the unit within a central heating system. Connection to the various system components is made via the wiring centre fitted to the front of the Megaflo eco SystemReady SB (see Figure 14, page 23) and the terminal identification labels within the wiring centre to aid in connecting the various external system components such as the mains supply, programmer and boiler. The wiring to the external components is made using flexible cable, this should be secured using the integral cable grips located in the wiring centre.

Provision is made for the connection of a second CH zone (connection pipe supplied blanked off). Additional controls will be necessary to control the operation of the second CH zone, usually a second 22mm CH zone valve. Connection terminals are provided and identified in the wiring centre to enable any wiring to be connected to the same central position.

The mains supply must be via a double pole isolating switch with a contact separation of at least 3mm in both poles. The supply must be fused 3Amp. A supply cable of 1.0 to 1.5mm² cross sectional area should be used.

Immersion Heater(s)

The Megaflo eco SystemReady SB unit is supplied with a factory fitted immersion heater which can be used as an alternative heat source should the boiler supply need to be isolated from the Megaflo eco SystemReady SB unit. The immersion heater is located within the controls housing. Refer to Section 2, Figure 11, page 22 "Wiring and Operation" for details of wiring and operation of the immersion heater, 210 litre models and above are supplied with a second blanked off boss which can be used for the connection of a second immersion heater, should this be required.

To remove the blanking plug:

Isolate the cylinder from the electrical supply and ensure the cylinder is drained of water. Open the cover to the upper immersion heater boss. Unscrew the brass backnut using the key spanner provided with the unit. Remove the blanking plate and sealing gasket from the boss.

Fitting additional immersion heater:

Insert the immersion heater and sealing gasket into the upper boss. Ensure that the sealing gasket is not displaced when inserting. It may be helpful to support the immersion heater using a round shafted screwdriver inserted into one of the thermostat pockets. Hand tighten the brass backnut. Secure the immersion heater in position by tightening with the key spanner provided. If an additional immersion heater and thermostat assembly is required, order part no. 95:970:554.

Figure 11 - Indirect Wiring Layout

Control Housing Details

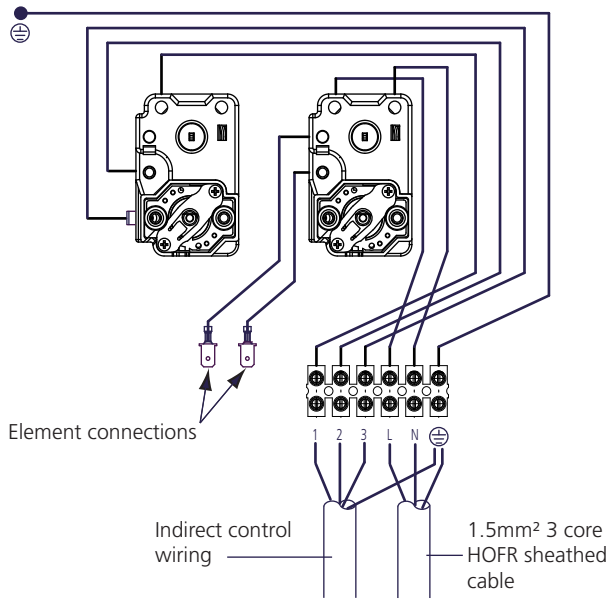
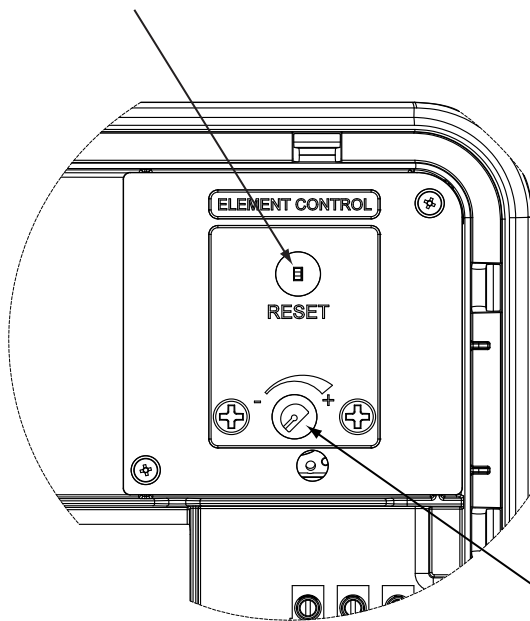

Figure 12 - Adjustment details

Thermal cut-out reset button



Spindle positions

☺ = Minimum temp

☹ = Maximum temp

☺ = Approx 60°C

Rotate spindle clockwise for temperature increase and counter-clockwise for temperature decrease

Figure 13 - Schematic Wiring Diagram - Indirect Circuit

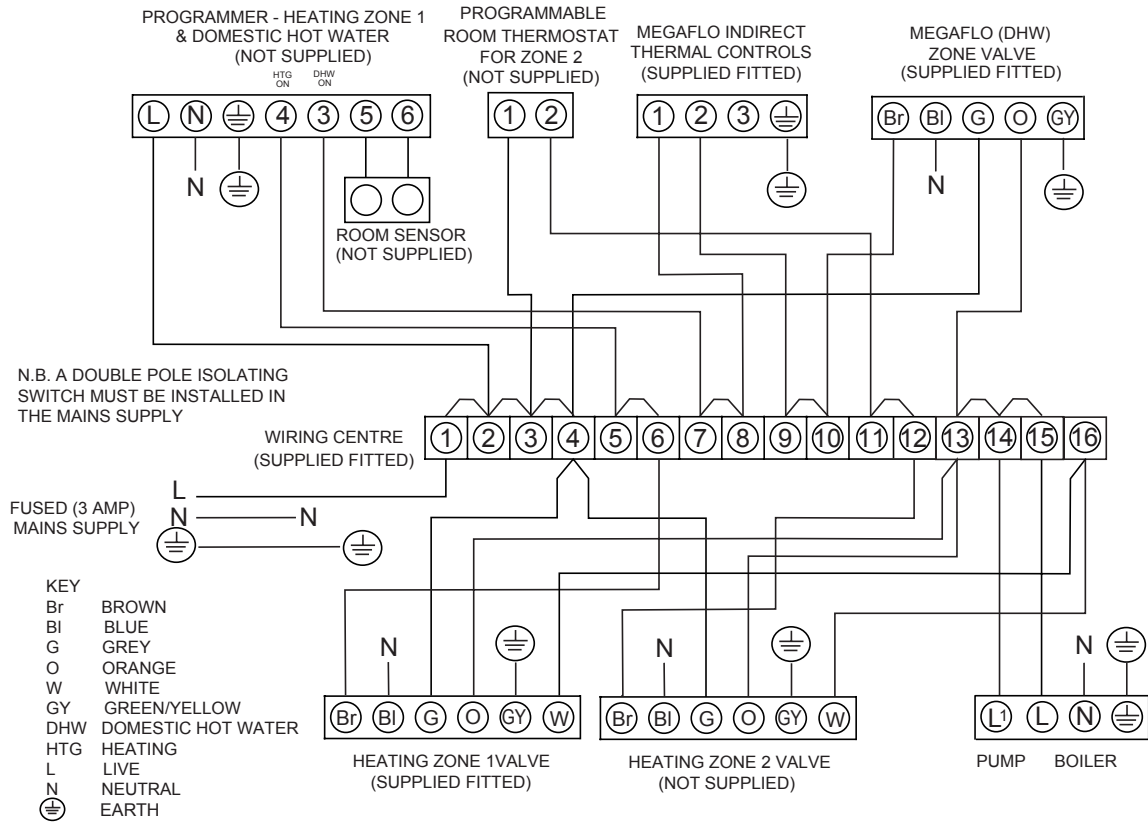

NOTES

1. ALL EARTH CONNECTIONS MUST BE LINKED BACK TO THE EARTH TERMINALS IN THE WIRING CENTRE
2. ALL NEUTRAL CONNECTIONS MUST BE LINKED BACK TO THE NEUTRAL TERMINALS IN THE WIRING CENTRE
3. ASSUMES BASIC BOILER
4. THE 22mm MOTORIZED VALVES DO NOT HAVE A WHITE WIRE
5. THE ABOVE DIAGRAM IS FOR GUIDANCE ONLY, HEATRAE SADIA ACCEPT NO LIABILITY FOR ANY LOSS OR DAMAGE ARISING FROM ANY ERRORS OR OMISSIONS THAT MAY BE INADVERTENTLY CONTAINED WITHIN THIS DIAGRAM. THE VARIOUS EQUIPMENT MANUFACTURERS SHOULD BE CONSULTED TO CONFIRM THE CORRECT OPERATION OF THEIR PRODUCTS WITHIN THE SYSTEM

Access to Control Unit:

Disconnect from mains supply before removing any covers.

Removing the Control Cover:

- Unscrew the large screw using a flat ended screw driver.
- Lift from bottom of cover at point indicated until cover comes away freely

Replacing the Control Cover:

- Tilt and align the top 2 lugs in the holes indicated
- Firmly press the cover until it "snaps" back in place.
- Tighten the large screw (**DO NOT OVER TIGHTEN**).

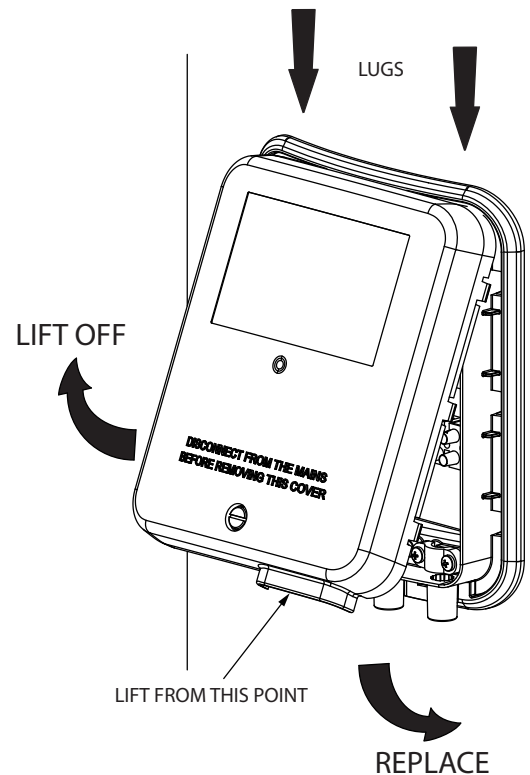

Commissioning

Filling and flushing the Megaflo eco SystemReady SB

Ensure that all fittings and immersion heaters are correctly fitted and tightened. An immersion heater key spanner is provided to aid in tightening the immersion heater(s).

- i) Open a hot tap furthest from the Megaflo eco SystemReady SB.
- ii) Open the isolating valve on the 3 bar pressure reducing valve by turning the blue handle on the isolating valve (if fitted in this position) so that it lies parallel to the direction of flow. Open the mains stop cock to fill the unit. When water discharges from the tap, allow to run for a few minutes to thoroughly flush through any residue, dirt or swarf, then close tap.
- iii) Open successive hot taps to purge any air from the system.
- iv) Check all connections for leaks and rectify as necessary.
- v) The strainer housed within the 3 bar pressure reducing valve should be cleaned to remove any debris that may have been flushed through the main supply pipe. Refer to Section 3, page 28 for instructions on how to do this.

Check the operation of the Safety Valves

- i) Slowly, manually open (turn black knob on end counter-clockwise), for a few seconds, the temperature and pressure relief valve (T&P valve) situated on the Megaflo eco SystemReady SB unit (see Figure 1, page 6). Check water discharged runs freely away through the tundish and discharge pipework. Close valve, ensure water flow stops and valve reseats correctly.
- ii) Repeat for the 8 bar pressure relief valve (see Figure 5, page 14).

Back Up Heating

Switch on the electrical supply to the immersion heater(s) and allow the unit to heat up. Check that the thermostat operates correctly. A storage temperature of approx. 60°C is recommended. If necessary the temperature can be adjusted by inserting a flat bladed screwdriver in the adjustment knob on top of the immersion heater thermostat and rotating clockwise (see Figure 12, page 22). The full adjustment represents a temperature range of between 12°C and 68°C. Check that no water is discharged from either the expansion valve or temperature and pressure relief valve during the heating cycle.

Indirect (Primary) Circuit

Fill the indirect primary circuit following the boiler manufacturer's commissioning instructions. Ensure the filling loop hose is connected at both ends and is tight. Open the isolating valves at either end of the filling loop and allow to fill from the mains inlet supply. To ensure the primary heating system is correctly filled the 2-port motorised valves should be manually opened by moving the lever on the motor housings to the MAN OPEN setting. The primary system should be pressurised to the minimum pressure required by the boiler (usually 1 bar), the pressure gauge fitted should be used to ensure the correct system pressure is set. When full and pressurised, the filling loop isolating valves should be closed and the levers on the motorised valves returned to the AUTO position.

Vent any trapped air, NOTE the radiators and boiler should be separately vented, the auto air vent will not vent all air at commissioning. Check the primary system for leaks and rectify as necessary. Flush the primary system in accordance with the boiler manufacturers instructions and add a suitable inhibitor when re-filling. Repeat above process whenever refilling. Switch on the electrical supply to the Megaflo eco SystemReady indirect controls and the boiler. Programme the Megaflo eco SystemReady SB controller as detailed in the fitting and user instruction leaflet supplied with the controller. Set the controller for hot water operation only (the +1HR ON hot water override button can be used if the time is during a Hot Water OFF period). Check that the heating 2-port motorised valve is closed and that the hot water 2-Port motorised valve opens. The pump should run and the boiler fire (tap symbol appears in controller display). The primary flow to the Megaflo eco SystemReady SB should become hot, if it does not, check for a wiring or piping error. Allow the Megaflo eco unit to heat up and check that the hot water thermostat and 2-Port motorised valve operate correctly. A storage temperature of approx. 60°C is recommended (see Figure 12, page 22 for approximate setting of 60°C). If necessary the temperature can be adjusted by inserting a flat bladed screwdriver in the adjustment knob (located on the front of the thermostat mounting bracket, see Figure 12 page 22) and rotating.

The minimum thermostat setting is 12°C. Select the heating only function on the controller. NOTE: The room temperature is set at the controller, no adjustment is possible at the room sensor unit. Check that the heating 2-port motorised valve opens and that the hot water 2-port motorised valve is closed. The pump should run and the boiler fire (a flame symbol appears in the controller display). The primary flow to the Megaflo eco SystemReady SB and the radiator circuit should become hot, If a second CH zone is fitted, adjust the programmable room thermostat so that it is calling for heat. Check that the second CH zone valve opens. The pump should run and the boiler fire. The primary flow to the second CH zone should become hot, if it does not, check for a wiring or piping error. Select the heating and hot water control function on the controller. Check that the heating 2-port motorised valve and the hot water 2-port motorised valve open. NOTE: It may be necessary to cool the Megaflo eco SystemReady SB down to allow the indirect thermostat to call for heat, it may also be necessary to increase the required room temperature setting if the room temperature has already reached that programmed. The pump should run and the boiler fire (both a tap symbol and a flame symbol should appear in the controller display). The primary flow to the Megaflo eco SystemReady SB and the radiator circuit should become hot, if it does not check for a wiring or piping error.

Megaflo eco SystemReady SB unit (See Maintenance and Servicing, pages 28 & 30).

Benchmark™ Log Book

On completion of the installation and commissioning procedures detailed in this manual, the Benchmark™ “Installation, Commissioning and Service Record Log, pages 34 and 35” should be completed and signed off by the competent installer or commissioning engineer in the relevant sections. The various system features, location of system controls, user instructions and what to do in the event of a system failure should be explained to the customer. The customer should then countersign the Benchmark™ commissioning checklist (page 34) to accept completion. The Service Record should be filled in when any subsequent service or maintenance operation is carried out on the product.

NOTES.

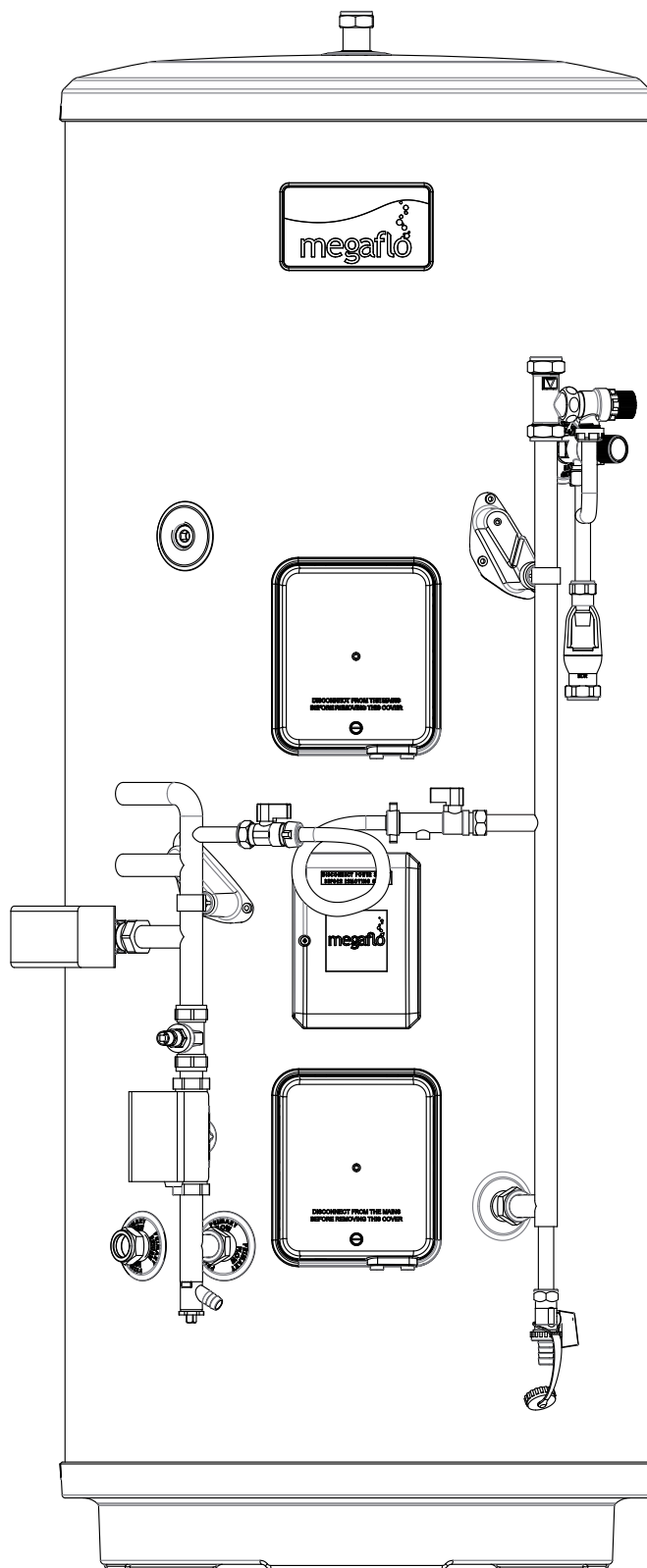

- Maintenance
- Fault Finding
- Servicing
- Spares
- Benchmark

Maintenance

Maintenance requirements

To ensure the continued optimum performance of the Megaflo eco SystemReady SB it should be regularly maintained. This is of particular importance in hard water areas or where the water supply contains particulate matter. Maintenance should be carried out by a competent person and any replacement parts used should be authorised Megaflo eco spare parts. It is recommended that maintenance is carried out every 12 months and includes the checks detailed below.

In hard water areas consideration should be given to periodically descaling the immersion heater elements. To do this the Megaflo eco SystemReady SB unit will need to be drained, details below list how to drain the unit and remove the immersion heater(s).

Check operation of Safety Valves

Slowly open the temperature and pressure relief valve by twisting its cap for a few seconds. Check water is discharged and that it flows freely through the tundish and discharge pipework. Check valve reseats correctly when released.

NOTE: The water discharged may be very hot.

Repeat the procedure for the 8 bar pressure relief valve.

Clean the strainer

The strainer is incorporated within the pressure reducing valve housing of the cold water combination valve (see Figure 17, page 31). To inspect and clean the strainer:

- i) Turn off the isolating valve on the 3 bar pressure reducing valve by turning the blue handle (if fitted in the position) so it lies 90° to the direction of flow.
- ii) Open the lowest hot tap in the system to relieve the system pressure.
- iii) Using a spanner unscrew the pressure reducing cartridge and remove the moulded housing. The strainer will be removed with the cartridge.
- iv) Wash any particulate matter from the strainer under clean running water.
- v) Replace the strainer and screw the pressure reducing valve cartridge into the moulded housing.
- vi) Close hot tap, turn on isolating valve by turning handle so it lies parallel to the direction of flow. Check for leaks.

Draining the Megaflo eco SystemReady SB unit

Switch off the electrical supply to the immersion heater(s) and shut down the boiler on indirect units. Turn off the mains water supply to the Megaflo eco SystemReady SB unit. Attach a hosepipe to the drain cock having sufficient length to take water to a suitable discharge point below the level of the unit, at least one metre below the unit is recommended. Open hot water tap nearest to the Megaflo eco SystemReady SB to relieve the system pressure. Open drain cock. If water fails to drain from the Megaflo eco SystemReady SB, vent the unit by manually opening the temperature / pressure relief valve.

Descaling immersion heater(s)

Switch off the electrical supply to the immersion heater(s) and shut down the boiler on indirect units. Turn off the mains water supply to the Megaflo eco SystemReady SB unit. Open the cover to the immersion heater housing and disconnect wiring from immersion heater. Remove the thermostat capillaries (4). Unscrew immersion heater backnut and remove immersion heater from the unit. A key spanner is supplied with the Megaflo eco SystemReady SB unit for easy removal / tightening of the immersion heater. Over time, the immersion heater gasket may become stuck to the mating surface. To break the seal insert a round shafted screwdriver into one of the pockets on the immersion heater and gently lever up and down.

Carefully remove any scale from the surface of the element. DO NOT use a sharp implement as damage to the element surface could be caused. Ensure sealing surfaces are clean and seals are undamaged, if in doubt fit a new gasket (95:611:822) to the immersion plate.

Replace immersion heater ensuring the right angled element hangs vertically downwards towards the base of the unit. It may be helpful to support the immersion heater using a round shafted screwdriver inserted into one of the thermostat pockets whilst the backnut is tightened. Replace the thermostat by carefully connecting the thermostat wire.

Rewire the immersion heater(s) in accordance with Figure 11, page 22 or Figure 12, page 22 if an additional immersion is fitted. Close and secure terminal cover(s).

Refilling system

DO NOT switch on the immersion heater(s) or boiler until the system has been completely refilled.

Close the drain tap. With the hot tap open, turn on mains water supply. When water flows from the hot tap allow to flow for a short while to purge air and to flush through any disturbed particles. Close hot tap and then open successive hot taps in system to purge any air. The electrical supply can now be switched on.

Benchmark™

On completion of any maintenance or service of the Megaflo eco SystemReady SB, the Benchmark™ "Installation, Commissioning and Service Record" should be filled in to record the actions taken and the date the work was undertaken.

Fault finding

The Fault Finding chart (Table 6 below) will enable operational faults to be identified and their possible causes rectified. Any work carried out on the Megaflo eco SystemReady SB unvented water heater and its associated controls MUST be carried out by a competent installer for unvented water heating systems. In case of doubt contact the Megaflo eco SystemReady SB Service Department, Section 4, page 40.

Table 6 - Fault Finding Chart

| FAULT | POSSIBLE CAUSE | REMEDY |
|--|--|--|
| No hot water flow | 1. Mains water supply off. | 1. Check and open stop cock. |
| | 2. Strainer blocked. | 2. Turn off water supply. Remove strainer and clean (see page 28). |
| | 3. Cold water combination valve incorrectly fitted. | 3. Check and refit as required. |
| Water from hot taps is cold | 1. INDIRECT programmer set to central heating only. | 1. Check. Set to a domestic hot water programme. |
| | 2. INDIRECT boiler not working. | 2. Check boiler operation. If fault is suspected consult boiler manufacturer's instructions. |
| | 3. INDIRECT thermal cut-out has operated. | 3. Check. Reset by pushing button on cut-out. Check operation of indirect thermostat (Figure 13, page 22). |
| | 4. INDIRECT motorised valve not connected correctly. | 4. Check wiring and/or plumbing connections to motorised valve (see Fig 14) Page 23). |
| | 5. BACK UP immersion heater not switched on. | 5. Check and switch on. |
| | 6. BACK UP immersion heater thermal cut-out has operated. | 6. Check. Reset by pushing button. (Figure 13, page 22) |
| Water discharges from Expansion Valve | 1. INTERMITTENTLY Air volume in Megaflo eco has reduced. | 1. See Page 39 (Operational Faults section for re-charging) |
| | 2. CONTINUALLY a. 3 bar pressure reducing valve not working correctly b. Expansion valve seat damaged. | 2a. Check pressure from 3 bar pressure reducing valve. If greater than 3 bar, replace pressure reducer cartridge. 2b. Remove expansion relief cartridge from 8 bar pressure relief valve and check seating. If necessary fit new cartridge. |
| Water discharges from T&P Relief Valve | 1. Thermal control failure NOTE water will be very hot. | 1. Switch off power to immersion heater(s) and shut down boiler. DO NOT turn off water supply. When discharge stops check all thermal controls, replace if faulty. |
| Milky water (this is quite normal) | 1. Oxygenated water. | 1. Water from a pressurised system releases oxygen bubbles when flowing. The milkiness will disappear after a short while. |

Servicing Important

- i) Servicing should only be carried by authorised heateam engineers or agents or by installers competent in the installation and maintenance of unvented water heating systems.
- ii) Any spare parts used MUST be authorised Megaflo eco parts.
- iii) Disconnect the electrical supply before removing any electrical equipment covers.
- iv) NEVER bypass any thermal controls or operate system without the necessary safety valves.
- v) Water contained in the Megaflo eco SystemReady SB unit may be very hot, especially following a thermal control failure. Caution must be taken when drawing water from the unit.

Spares

Spare parts

A full range of spare parts are available for the Megaflo eco SystemReady SB range. Refer to the Technical Data label on the unit to identify the model installed and ensure the correct part is ordered.

| Description | Part no. | Description | Part no. |
|--|------------|-----------------------------|------------|
| Cold Water Inlet Control Kit - Complete | 95:605:894 | Wiring Centre | 95:612:702 |
| 3 Bar Pressure Reducing Valve - Complete | 95:605:886 | TP1 Room Temperature Sensor | 95:607:904 |
| 8 Bar Pressure Relief Valve - Complete | 95:605:893 | Automatic Air vent | 95:605:050 |
| Stopcock | 95:605:885 | Filling Loop and Connection | 95:607:096 |
| Immersion Heater Backnut | 95:607:940 | | |
| Immersion Heater Gasket | 95:611:822 | | |
| Immersion Heater Key | 95:607:861 | | |
| Immersion Heater Blanking Plug | 95:605:881 | | |
| Titanium Immersion Heater - Upper | 95:606:989 | | |
| Direct Combined Thermostat / Thermal Cut-Out | 95:612:717 | | |
| Tundish | 95:605:838 | | |
| Insulation Set (T & P Relief Valve) | 95:607:922 | | |
| Mounting Plate (Indirect) | 95:607:931 | | |
| Indirect Control Cover | 95:614:118 | | |
| 6 way Terminal Block | 95:607:933 | | |
| 2 Port Motorised Valve (22mm Connections) | 95:605:819 | | |
| Incoloy Immersion Heater - Lower | 95:606:984 | | |
| Indirect Combined Thermostat and Cut-out | 95:612:716 | | |
| Temperature / Pressure Relief Valve | 95:605:810 | | |
| Set of Compression Nuts and Olives | 95:607:838 | | |
| Drain Valve 1/4 Turn | 95:605:051 | | |

Figure 15 - Exploded view of 3 Bar Inlet Control Valve

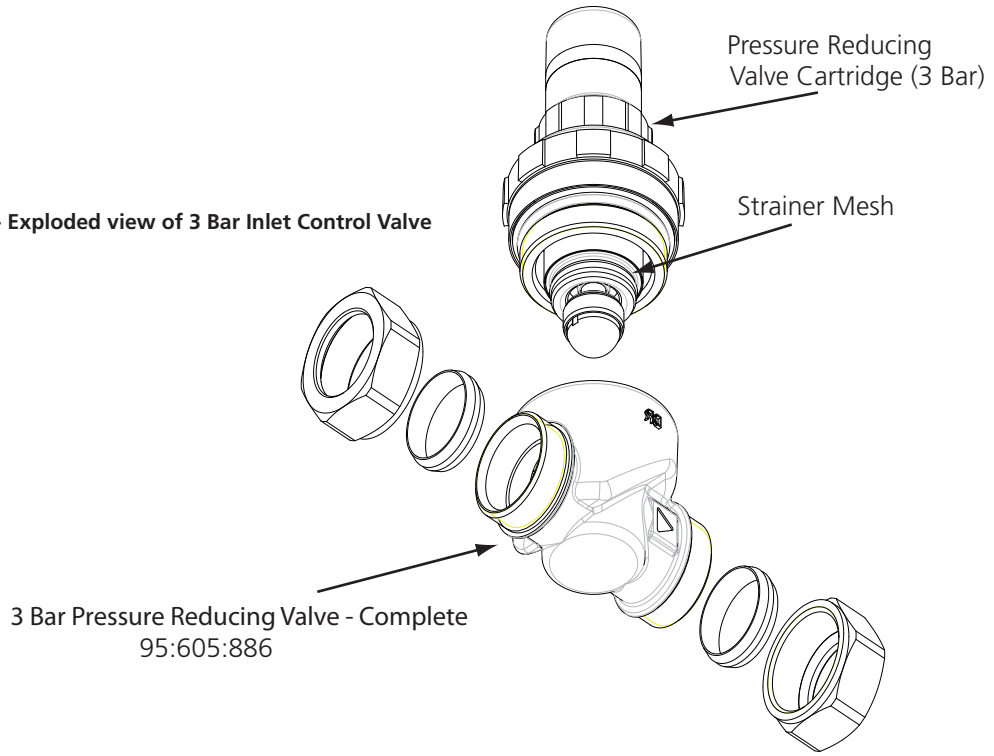
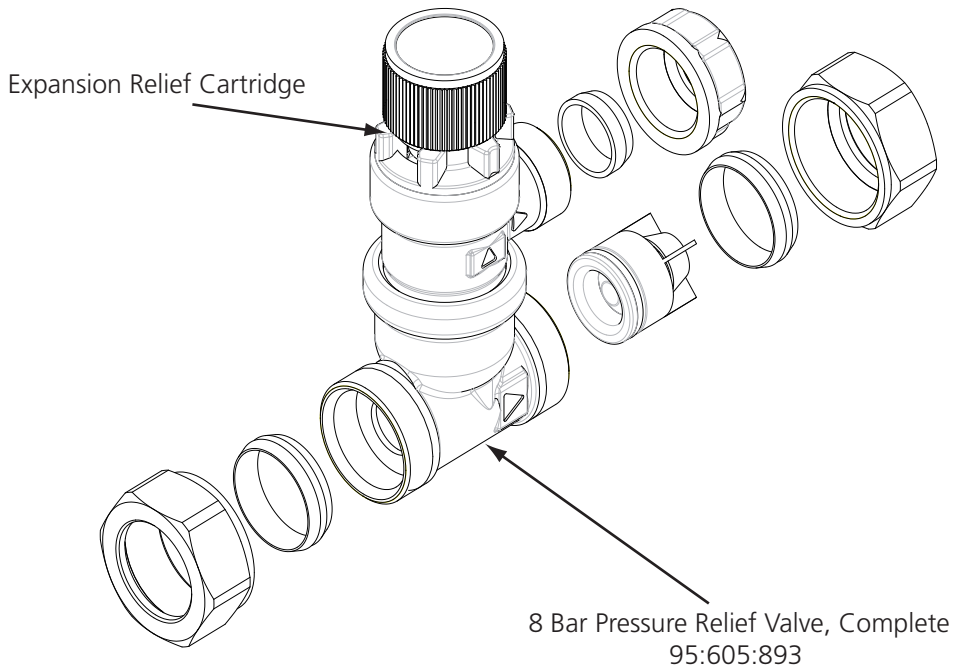

Figure 16 - Exploded View of 8 Bar Pressure Relief Valve



Isolating valve can be used either with
3 bar inlet control valve or 8 bar
pressure relief valve
95605885

Figure 17 - Exploded View of Isolating valve

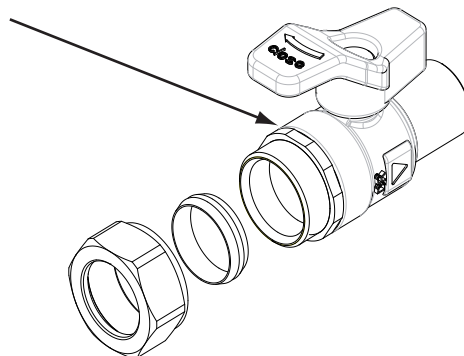

Figure 18: Indirect Exploded View

Indirect Control Assembly

For 210 litre and above a further indirect control assembly accessory is available 95:970:554

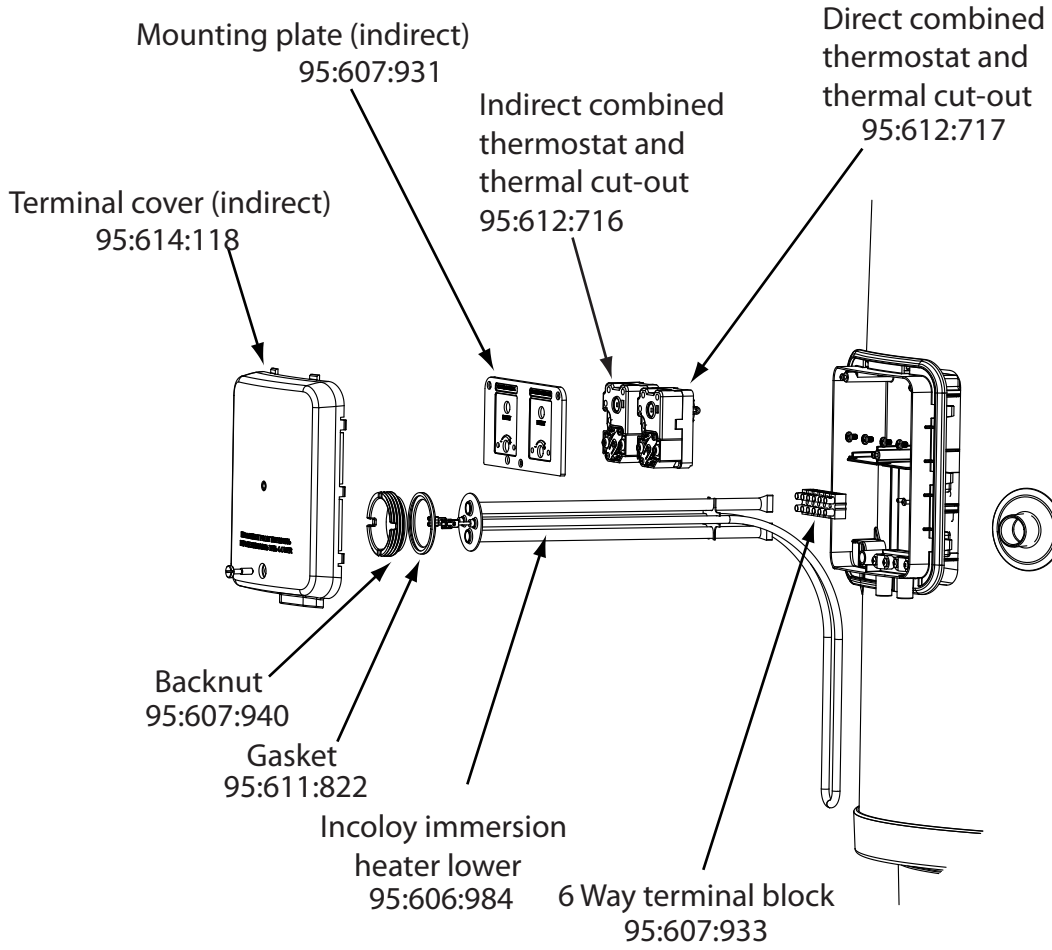
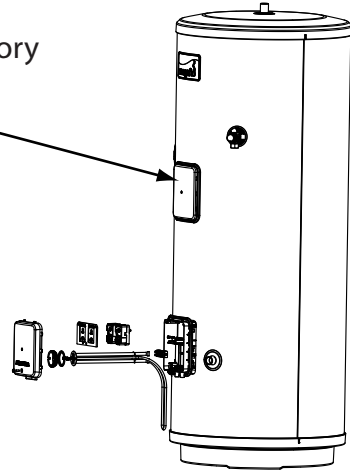
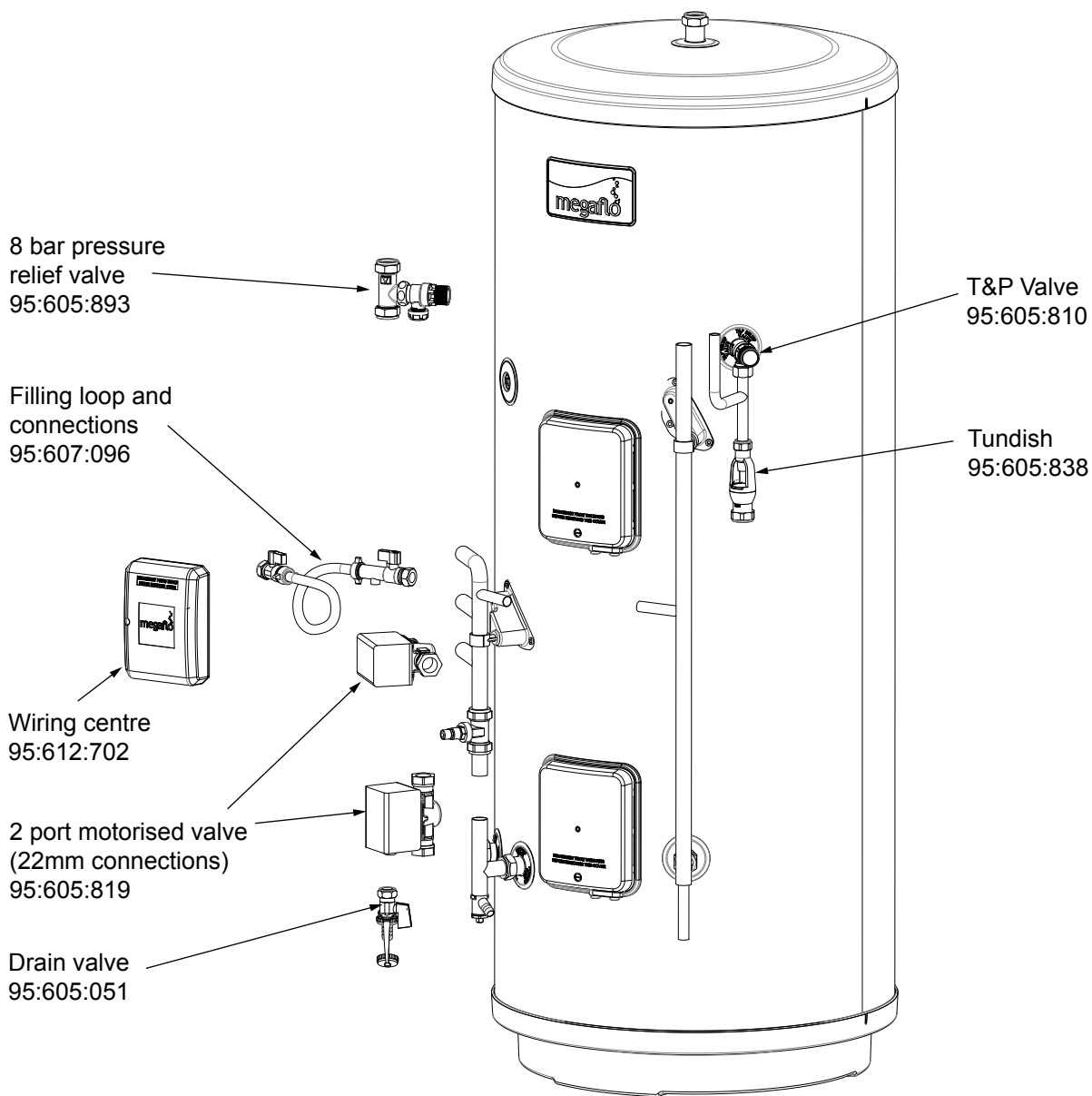

Figure 19: SystemReady Exploded View



MAINTENANCE AND
 SERVICING (3)

MAINS PRESSURE HOT WATER STORAGE SYSTEM COMMISSIONING CHECKLIST

This Commissioning Checklist is to be completed in full by the competent person who commissioned the storage system as a means of demonstrating compliance with the appropriate Building Regulations and then handed to the customer to keep for future reference.

Failure to install and commission this equipment to the manufacturer's instructions may invalidate the warranty but does not affect statutory rights.

Customer Name _____ Telephone Number _____
 Address _____
 Cylinder Make and Model _____
 Cylinder Serial Number _____
 Commissioned by (print name) _____ Registered Operative ID Number _____
 Company Name _____ Telephone Number _____
 Company Address _____
 _____ Commissioning Date _____

To be completed by the customer on receipt of a Building Regulations Compliance Certificate*:

Building Regulations Notification Number (if applicable) _____

ALL SYSTEMS PRIMARY SETTINGS (indirect heating only)

Is the primary circuit a sealed or open vented system? Sealed Open
 What is the maximum primary flow temperature? _____ °C

ALL SYSTEMS

What is the incoming static cold water pressure at the inlet to the system? _____ bar
 Has a strainer been cleaned of installation debris (if fitted)? Yes No
 Is the installation in a hard water area (above 200ppm)? Yes No
 If yes, has a water scale reducer been fitted? Yes No
 What type of scale reducer has been fitted? _____
 What is the hot water thermostat set temperature? _____ °C
 What is the maximum hot water flow rate at set thermostat temperature (measured at high flow outlet)? _____ l/min
 Time and temperature controls have been fitted in compliance with Part L of the Building Regulations? Yes
 Type of control system (if applicable) Y Plan S Plan Other
 Is the cylinder solar (or other renewable) compatible? Yes No
 What is the hot water temperature at the nearest outlet? _____ °C
 All appropriate pipes have been insulated up to 1 metre or the point where they become concealed Yes

UNVENTED SYSTEMS ONLY

Where is the pressure reducing valve situated (if fitted)? _____
 What is the pressure reducing valve setting? _____ bar
 Has a combined temperature and pressure relief valve and expansion valve been fitted and discharge tested? Yes No
 The tundish and discharge pipework have been connected and terminated to Part G of the Building Regulations Yes
 Are all energy sources fitted with a cut out device? Yes No
 Has the expansion vessel or internal air space been checked? Yes No

THERMAL STORES ONLY

What store temperature is achievable? _____ °C
 What is the maximum hot water temperature? _____ °C

ALL INSTALLATIONS

The hot water system complies with the appropriate Building Regulations Yes
 The system has been installed and commissioned in accordance with the manufacturer's instructions Yes
 The system controls have been demonstrated to and understood by the customer Yes
 The manufacturer's literature, including Benchmark Checklist and Service Record, has been explained and left with the customer Yes

Commissioning Engineer's Signature _____
 Customer's Signature _____
 (To confirm satisfactory demonstration and receipt of manufacturer's literature)

*All installations in England and Wales must be notified to Local Authority Building Control (LABC) either directly or through a Competent Persons Scheme. A Building Regulations Compliance Certificate will then be issued to the customer.



SERVICE RECORD

It is recommended that your hot water system is serviced regularly and that the appropriate Service Record is completed.

Service Provider

Before completing the appropriate Service Record below, please ensure you have carried out the service as described in the manufacturer's instructions.

SERVICE 1 Date _____
Engineer Name _____
Company Name _____
Telephone Number _____
Comments _____

Signature _____

SERVICE 2 Date _____
Engineer Name _____
Company Name _____
Telephone Number _____
Comments _____

Signature _____

SERVICE 3 Date _____
Engineer Name _____
Company Name _____
Telephone Number _____
Comments _____

Signature _____

SERVICE 4 Date _____
Engineer Name _____
Company Name _____
Telephone Number _____
Comments _____

Signature _____

SERVICE 5 Date _____
Engineer Name _____
Company Name _____
Telephone Number _____
Comments _____

Signature _____

SERVICE 6 Date _____
Engineer Name _____
Company Name _____
Telephone Number _____
Comments _____

Signature _____

SERVICE 7 Date _____
Engineer Name _____
Company Name _____
Telephone Number _____
Comments _____

Signature _____

SERVICE 8 Date _____
Engineer Name _____
Company Name _____
Telephone Number _____
Comments _____

Signature _____

SERVICE 9 Date _____
Engineer Name _____
Company Name _____
Telephone Number _____
Comments _____

Signature _____

SERVICE 10 Date _____
Engineer Name _____
Company Name _____
Telephone Number _____
Comments _____

Signature _____

MAINTENANCE AND
SERVICING (3)

Spares Stockists

Electric Water Heating Co.
2 Horsecroft Place
Pinnacles
Harlow
Essex
CM19 5BT
E-Mail: sales@ewh.co.uk

SPD
Special Product Division
Units 9 & 10
Hexagon Business Centre
Springfield Road
Hayes

Middlesex
UB40 0TY

Parts Center
Network 65 Business Park
Bentley Wood Way
Burnley
Lancashire
BB11 5ST
Tel: 01282 834403
www.partscenter.co.uk

Newey & Eyre
Specialist Products Division
Please Contact your Local Branch

UK Spares Ltd
Unit 1155 Aztec West
Almonsbury
Bristol
BS32 4TF
Tel:01454 620 500

William Wilson Ltd
Unit 3A
780 South Street
Whiteinch
Glasgow
G14 0SY
Tel: 0141 434 1530

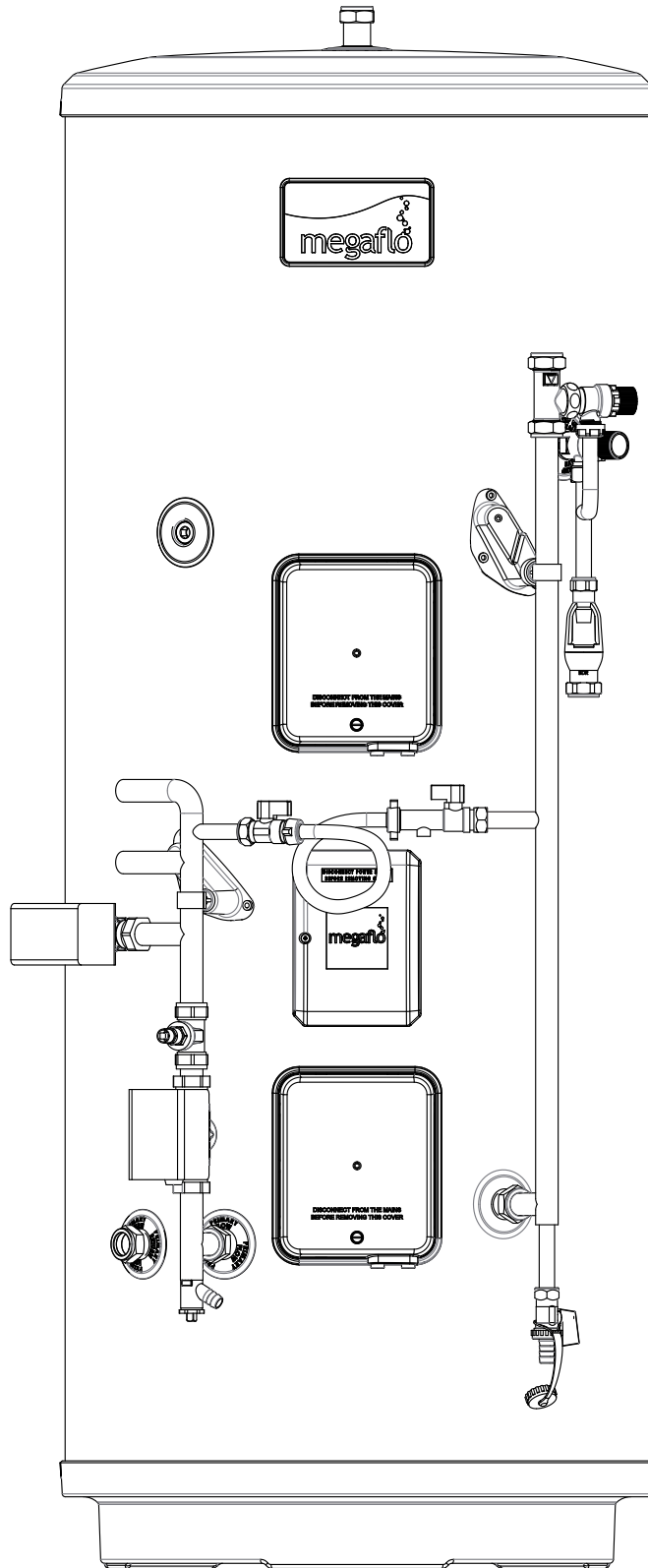

- User Instructions
- Guarantee
- Customer Service

IMPORTANT LEGAL REQUIREMENT FOR INSTALLERS

Megaflor eco SystemReady SB is a trading name of Heatrae Sadia Heating, a licensed member of the Benchmark™ Scheme which aims to improve the standards of installation and commissioning of domestic heating and hot water systems in the UK and to encourage regular servicing to optimise safety, efficiency and performance. It is managed and promoted by the Heating and Hotwater industry Council. For more information visit www.centralheating.co.uk. Please ensure that the installer has fully completed the Checklist on Page 34 of this manual and that you have signed it to say that you have received a full and clear explanation of its operation. The installer is legally required to complete a commissioning checklist as a means of complying with the appropriate Building Regulations (England and Wales). All installations must be notified to Local Area Building Control either directly or through a Competent Persons Scheme. A Building Regulations Compliance Certificate will then be issued to the customer who should, on receipt, write the Notification Number on the Checklist. This product should be serviced regularly to optimise its safety, efficiency and performance. The service engineer should complete the relevant Service Record on the Checklist after each service. The Checklist may be required in the event of any warranty work.

User Instructions

Warnings

IF WATER ISSUES FROM THE TEMPERATURE / PRESSURE RELIEF VALVE ON THE MEGAFLO ECO SystemReady SB UNIT, REFER TO PAGE 29 (TABLE 6) FIRST FOR GUIDANCE. IF THIS DOES NOT RECTIFY THE FAULT SWITCH OFF ELECTRICAL SUPPLY TO THE IMMERSION HEATER(S) OR SHUT DOWN THE BOILER

DO NOT TURN OFF THE WATER SUPPLY. CONTACT A COMPETENT INSTALLER FOR UNVENTED WATER HEATERS TO CHECK THE SYSTEM.

DO NOT TAMPER WITH ANY OF THE SAFETY VALVES FITTED TO THE MEGAFLO ECO SystemReady SB. IF A FAULT IS SUSPECTED, CONTACT A COMPETENT INSTALLER.

Immersion Heaters

A combined thermostat and thermal cut-out is provided for each immersion heater. The thermostat is factory set to give a water storage temperature of approx. 60°C, however it can be set to control between 12°C and 68°C. This will usually have been done during installation. Adjustments can only be made by opening the terminal cover(s). **DO NOT remove the cover(s) without first switching off the electrical supply.** The temperature adjustment is made by inserting a flat bladed screwdriver in the slot in the disc on top of the thermostat and rotating (see Figure 12, page 22).

If in any doubt consult a competent electrician.

Indirect units are fitted with an indirect thermostat which controls a 2-port motorised valve and hence the temperature of the water in the Megaflor eco SystemReady SB unit. The thermostat is factory set to give a water storage temperature of approx 60°C, however it can be set to control between 12°C and 68°C. This will usually have been done during installation. Adjustments can be made by opening the terminal cover. **DO NOT REMOVE THE COVER WITHOUT FIRST SWITCHING OFF THE ELECTRICAL SUPPLY.** Temperature adjustment is made by inserting a flat bladed screwdriver in the adjustment knob located on the front of the thermostat mounting bracket (see Figure 12, page 22) and rotating. At the minimum position the temperature will be approx 12°C.

If in any doubt consult a competent electrician.

Flow Performance

When initially opening hot outlets, a small surge in flow may be noticed as pressures stabilise. This is quite normal with unvented systems and does not indicate a fault. In some areas, a cloudiness may be noticed in the hot water. This is due to aeration of the water, is quite normal and will quickly clear.

Operational Faults

Operational faults and their possible causes are detailed in Table 6, page 29 . It is recommended that faults should be checked by a competent installer.

The air volume within the Megaflo eco SystemReady SB unit will periodically require recharging to ensure any expanded water is accommodated within the cylinder. A discharge of water **INTERMITTENTLY** from the expansion relief valve will indicate the air volume has reduced to a point where it can no longer accommodate the water expansion. To recharge the air volume:-

- i) Turn off the heat source to the cylinder via programmers / immersion isolation switch(es).
- ii) Turn off the water supply to the Megaflo eco SystemReady SB unit by turning off the isolating valve on the 3 bar pressure reducing valve if fitted at this point or at the 8 bar pressure relief valve if fitted there. Turn the blue handle so that it lies at 90° to the direction of flow (see Figures 4 and 5, Page 14 for options on valve set) .
- iii) Open the lowest hot tap supplied by the Megaflo eco SystemReady SB.
- iv) Hold open the temperature / pressure relief valve until water ceases to run from the tap and gurgling noise at the valve stops.
- v) Close the temperature / pressure relief valve.
- vi) Turn on the isolating valve at the cold water combination valve by turning the blue handle so it lies parallel to the direction of flow, when water flows from the hot tap, close tap.
- vii) The air volume will be automatically recharged as the unit refills. If after following the above actions water still discharges from the expansion relief valve, further advice should be sought from a competent installer or the Megaflo eco Service Department.

Lifetime Warranty*

The MEGAFLO Lifetime Warranty provides unrivalled levels of customer support and peace of mind in the unlikely event that a problem arises from a manufacturing defect. It is supported by a large nationwide team of company-employed field-based engineers and our own call centre, which is open 363 days a year.

This Lifetime Warranty applies in relation to the following MEGAFLO products:

- MEGAFLO cylinders
- MEGAFLO calorifiers

The MEGAFLO Domestic Lifetime* Warranty

The MEGAFLO Domestic Lifetime* Warranty covers MEGAFLO cylinders installed in domestic properties† against corrosion for the lifetime* of the owner.

The cold water combination valve (and expansion vessel, where supplied) is covered by a five year warranty from the date of purchase of the MEGAFLO product that includes both parts and labour. All other components, including any other valves, fittings and controls are covered by a two year warranty from the date of purchase of the MEGAFLO product that includes both parts and labour.

In the case of the Megaflo Systemready, Megaflo Systemfit and Megaflo SolaReady units the supplied pumps and motorized valves (where fitted) are also covered by this two year warranty.

Incalloy immersion heaters (where fitted) are covered by a two year warranty.

Titanium Immersion heaters (where fitted) are covered by a five year warranty.

The MEGAFLO Commercial Lifetime* Warranty

The MEGAFLO Commercial Lifetime Warranty covers MEGAFLO cylinders and calorifiers installed in non-domestic properties^ against corrosion for a period of 30 years from the date of purchase.

All other components, including valves, expansion vessels, immersion heaters, fittings and controls are covered by a two year warranty from the date of purchase of the MEGAFLO product that includes both parts and labour.

Accessories

Shower heat recovery units are covered against manufacturing defects for a period of two years. Flat plate solar collectors are covered against manufacturing defects for a period of 10 years from the date of purchase of the MEGAFLO product. Evacuated tube solar collectors are covered against manufacturing defects for a period of five years from the date of purchase of the MEGAFLO product. All other solar accessories are covered against manufacturing defects for a period of two years from the date of purchase of the MEGAFLO product.

Outside of the UK

These warranties are valid for installations within the United Kingdom.

For installation in the Republic of Ireland please contact Potterton Myson (Ireland) Limited on 00353 (0) 1 4590870

For installations outside of the United Kingdom and the Republic of Ireland, please telephone MEGAFLO Export on +44 1603 420271 for further details of the warranty terms and conditions applicable.

These guarantees are valid provided that:

- The MEGAFLO product has been installed by a competent installer in accordance with the instructions contained in the installation instructions and in compliance with all relevant laws, guidance, codes of practice and regulations in force at the time of installation.
- The MEGAFLO product has not been modified or tampered with in any way, other than by a Heatrae Sadia or Baxi Customer Support approved engineer.
- The MEGAFLO product has not been subject to damage by scale.
- The MEGAFLO product and any part or parts of the MEGAFLO product (whether factory fitted or otherwise) have not been repaired or replaced other than by a Baxi Customer Support approved engineer and any replacement parts used on

the MEGAFLO product are authorised MEGAFLO spare parts.

- The factory fitted temperature and pressure relief valve have not been tampered with or removed.
- The MEGAFLO product has not been subject to misuse or neglect.
- The MEGAFLO product has only been used for the storage of wholesome water. Should another substance be put through the product, the warranty will be invalid unless it is part of a disinfectant procedure carried out in accordance with BS EN 806.
- The MEGAFLO product has not been subjected to frost or freezing temperatures (except for solar collectors which are designed for external installation).
- The Benchmark™ commissioning checklist service record, included in the MEGAFLO installation instructions has been completed.
- Regular maintenance has been carried out by a competent person/, an approved engineer from Heatrae Sadia or any other part of the Baxi Group Baxi Customer Support approved engineer in accordance with the requirements set out in the maintenance section of the installation instructions.
- Access is available, at reasonable times and upon reasonable notice, to the MEGAFLO product to allow for any inspection repair or replacement.
- The product is registered within 60 days of purchase. This can be done by telephone, online or by using the registration form provided with the product.
- Evidence of purchase (for example a receipt or delivery note) and date of supply is submitted when making a claim.
- The MEGAFLO product has not been affected by any cause beyond our reasonable control including, without limitation: an act of God, explosion, flood, fire or accident; war or civil disturbance; strike, industrial action or stoppages of work; any form of government intervention; a third party act or omission including theft or malicious damage; failure by you to give us a correct delivery address or notify us of any change of address.

If any of the following situations occur, the MEGAFLO Lifetime Warranty* will not apply:

- Any wilful or accidental damage caused by your negligence
- Damage caused as a result of scale.
- Installation not in line with the installer and user manuals provided,
- Failure to comply with installation instructions (whether oral or in writing),
- Misuse of the MEGAFLO product or alteration of the MEGAFLO product not in accordance with the requirements set out above.
- Defects which are not reported to us outside of the warranty period on 03444 8711535 or customer.support@baxi.co.uk
- Any third party repair or replacement costs unless those costs have been agreed and authorised by Baxi Customer Support or Heatrae Sadia in writing prior to incurring the costs.
- In relation to the MEGAFLO Commercial Lifetime Warranty only, we will not be liable for any indirect and consequential losses and any loss of earnings, loss of business, or losses in relation to stress and inconvenience, howsoever caused.

Claims

Defects should be reported to us as soon as you are aware of them. Please report defect to us by contacting 03444 8711535 or customer.support@baxi.co.uk.

Notes

We are only able to carry out warranty repair/replacement to MEGAFLO solar collectors which have safe access and that meet current Health & Safety working at heights requirements. The customer will cover the cost of any safety equipment including but limited to scaffolding and lifting equipment that is required to meet this standard and will appoint a contractor to carry this work out.

Heatrae Sadia accepts no liability for any third party damage.

These warranties do not affect your statutory rights and remedies in relation to the MEGAFLO products.

Annual service

Annual services are available from Baxi Customer Support, the service division of Heatrae Sadia.

Please contact Baxi Customer Support on 0844 871 1535 for details.

*In domestic† properties, lifetime is the period during which the first owner of the MEGAFLO or new build home continues to own the property. Should the property be sold, the new owner and any subsequent owners will receive a 30 year warranty from the date the original owner purchased the MEGAFLO or new home with a MEGAFLO installed. In non-domestic properties lifetime is a period of 30 years from the date of purchase by the original owner and is transferable to any new owner of the property.

†Domestic is any premises not being, or ever having been, wholly or partly utilised for business purposes.

^Non-domestic premises are any premises other than those defined as Domestic.†

All MEGAFLO warranties are conditional on the installation being carried out in accordance with the installation instructions supplied with the product. These warranties do not affect your statutory rights. Full terms and conditions of these warranty packages are available on request or via www.heatraesadia.com/megaflo

Heatrae Sadia*, Hurricane Way, Norwich, Norfolk, NR6 6EA

MEGAFLO may introduce modifications to their products from time to time. Consequentially the details given in this brochure are subject to alteration without notice.

Contacts

Specification Advice Hotline

T: 01603 420220

F: 01603 420229

E: specifier@heatraesadia.com

www.heatraesadia.com

* Heatrae Sadia is a trading name of Baxi Heating UK Limited, Brooks House, Coventry Road, Warwick, CV34 4LL

July 2015

Notes



Customer service

Telephone:
0344 8711535

Facsimile:
0344 8711528

E-mail:
megaflo-service@heateam.co.uk

Megaflo
Hurricane Way
Norwich
Norfolk
NR6 6EA

BY **HEATRAESADIA**