

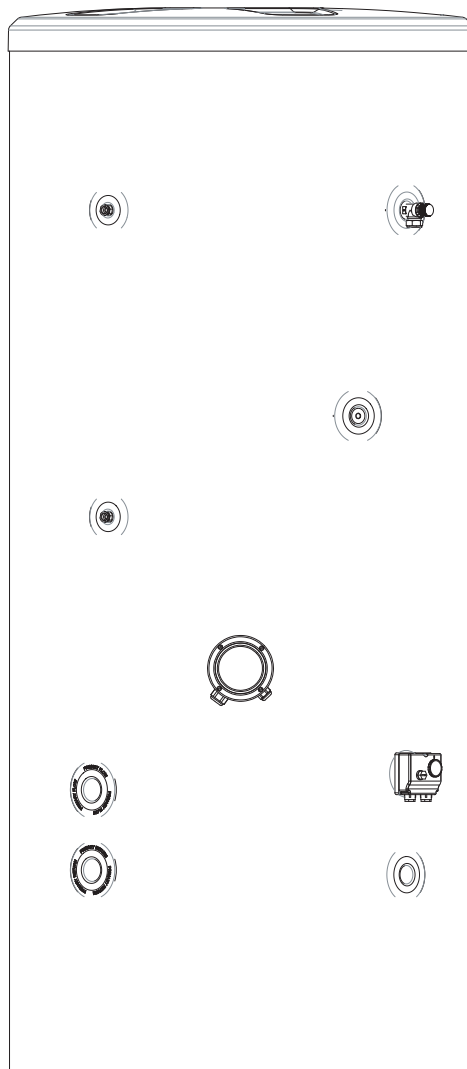

MegaFlo Eco Plus Unvented Indirect Hot Water Cylinders 800L - 1000L



Important

Please read & understand all these instructions before commencing installation.
Please leave this manual with the customer for future reference

MegaFlo Eco Plus Product Guide

Contents

1. Introduction	3
1.1 General.....	3
1.2 Symbols used.....	3
1.3 Abbreviations.....	3
1.4 Liabilities.....	3
2. Safety.....	4
2.1 General safety warnings.....	4
2.2 Recommendations	4
2.3 Specific safety instructions	4
3. Technical specifications	5
3.1 Technical data	5
3.2 Dimensions and connections	6
3.3 Electrical diagram(s).....	7
4. Description of the product	11
4.1 General description	11
4.2 Operation principle	11
4.3 Main components	11
4.4 Standard delivery	11
5. Before installation	13
5.1 Installation regulations.....	13
5.2 Installation requirements	13
5.3 Choice of location.....	13
5.4 Transport	14
6. Installation	15
6.1 General.....	15
6.2 Water connections.....	15
6.3 Electrical connections.....	21
6.4 Filling the installation	21
7. Commissioning	22
7.1 General.....	22
7.2 Checklist before commissioning.....	22
7.3 Commissioning procedure.....	22
8. Operation	23
8.1 General.....	23
9. Maintenance.....	24
9.1 General.....	24
9.2 Standard inspection & maintenance operations.....	24
10. Troubleshooting	26
10.1 Fault finding.....	26
11. Decommissioning.....	27
11.1 Decommissioning procedure	27
12. Spare parts.....	28
12.1 Spare parts list.....	28
Benchmark checklist	30
Commissioning & service records	31
Guarantee.....	32

1. Introduction

1.1 General

The following instructions are offered as a guide to the user and installer.

The installation must be carried out by a competent plumbing and electrical installer in accordance with Building Regulation G3 (England and Wales), Technical Standard P3 (Scotland) or Building Regulation P5 (Northern Ireland) and the Water Fitting Regulations (England and Wales) or Water Byelaws (Scotland).

1.2 Symbols used

In these instructions, various risk levels are employed to draw the user's attention to particular information. In doing so we wish to safeguard the user, avoid hazards and guarantee the correct operation of the appliance.



DANGER

Risk of a dangerous situation causing serious physical injury.



WARNING

Risk of dangerous situation causing slight physical injury.



CAUTION

Risk of material damage.



Signals important information.

1.3 Abbreviations

- ▶ T&P - Temperature & Pressure relief valve
- ▶ PRV - Pressure Reducing Valve
- ▶ Prv - Pressure relief valve

1.4 Liabilities

Manufacturers liability

Our products are manufactured in compliance with the requirements of the various applicable European Directives.

This appliance complies with the requirements of the CE marking directive.

In the interest of UK customers, we are continuously endeavouring to make improvements in product quality. All the specifications stated in this document are therefore subject to change without notice.

Our liability as the manufacturer may not be invoked in the following cases:

- ▶ Failure to abide by the instructions on using the appliance.
- ▶ Faulty or insufficient maintenance of the appliance.
- ▶ Failure to abide by the instructions on installing the product.

Installer's liability

The installer is responsible for the installation and the commissioning of the appliance. The installer must respect the following instructions:

- ▶ Read and follow the instructions given in the manuals provided with the appliance.
- ▶ Carry out installation in compliance with the prevailing legislation and standards.
- ▶ Perform the initial start up and carry out any checks necessary.
- ▶ Complete the commissioning checklist.
- ▶ Explain the installation to the user.
- ▶ If maintenance is necessary, warn the user of the obligation to check the appliance and maintain it in good working order.
- ▶ Give all the instruction manuals to the user.

Users liability

To guarantee optimum operation of the appliance, the user must respect the following instructions:

- ▶ Read and follow the instructions given in the manuals provided with the appliance.
- ▶ Call on qualified professionals to carry out installation and initial start up.
- ▶ Get your fitter to explain your installation to you.
- ▶ Have your required checks and services done.
- ▶ Keep the instruction manuals in good condition and close to the appliance.



This appliance can be used by children aged from 8 years and above and persons with reduced physical sensory or mental capabilities or lack of experience and knowledge if they have been given supervision or instruction concerning use of the appliance in a safe way and understand the hazards involved. Children shall not play with the appliance. Cleaning and user maintenance shall not be made by children without supervision.

Children must be supervised to ensure they do not play with the appliance.

2. Safety

2.1 General safety warnings



DANGER

This cylinder is unvented and as such becomes pressurised when in operation. The combination of pressurisation and hot water could lead to serious physical injury if the safety instructions in this manual are not adhered to.



WARNING

- ▶ Only competent persons having received adequate training are permitted to work on the appliance and the installation.
- ▶ Do not tamper with any of the safety valves or controls supplied with the cylinder.
- ▶ Before any work, switch off the mains supply to the appliance.
- ▶ Do not switch on if there is a possibility that the water in the cylinder is frozen.



CAUTION

Do not operate immersion heaters until the cylinder has been filled with water.

2.2 Recommendations



WARNING

When handling the unit, take appropriate precautions for the weight of the unit. Weights can be found in section 3, table 1 & 2, page 5 & 6.



CAUTION

Annual maintenance is recommended by a competent person.

2.3 Specific safety instructions



WARNING

- ▶ If water discharges from the temperature/pressure relief valve on the cylinder shut down the boiler. Do not turn off any water supply. Contact a competent installer for unvented water heaters to check the system.
- ▶ Do not tamper with any of the safety valves fitted to the system. If a fault is suspected contact a competent installer.
- ▶ DO NOT bypass the thermal cut-out(s) in any circumstances.

3. Technical specifications

3.1 Technical data

Indirect:

		800 indirect	1000 indirect
Max direct kW rating		6	6
Coil surface area m²		3	
Coil rating (kW)	15l/min	25.6	29.1
	30l/min	41.0	45.4
	60l/min	58.7	64.8
Indirect heat time (mins)	15l/min	73	88
	30l/min	47	57
	60l/min	33	40
Pressure drop through primary coil (MPa)	15l/min	0.002	
	30l/min	0.008	
	60l/min	0.030	
Heat loss (kWh in 24h)		2.74	3.33
Hot water capacity (volume of water drawn off >40°C)		630@60l/min	840@60l/min
Weight full (kg)		1011	1219
Weight empty (kg)		211	219
Max supply pressure		1.6MPa (16 bar)	
Max design pressure		0.8MPa (8 bar)	
Max operating pressure (PRV)		0.35MPa (3.5 bar)	
Max expansion vessel charge pressure		1.0MPa (10 bar)	
Expansion relief valve setting		0.8MPa (8 bar)	
T&P valve setting		1.0MPa (10 bar)/90°C	
Expansion PRV set pressure		0.8MPa (8 bar)	
Maximum primary pressure (see Note 3)		1.0MPa (10 bar)	

Notes:

1. Indirect cylinders tested in conformance with BS EN 12897:2006.
2. Heat up time from cold through 45°C, based on a flow temperature of 80°C +/- 2°C & normal volume.
3. The primary coil should not be exposed to more than 0.3MPa (3bar) without the cylinder being full of water and under the minimum working pressure.

Table 1: Technical data - Indirect

3.2 Dimensions and connections

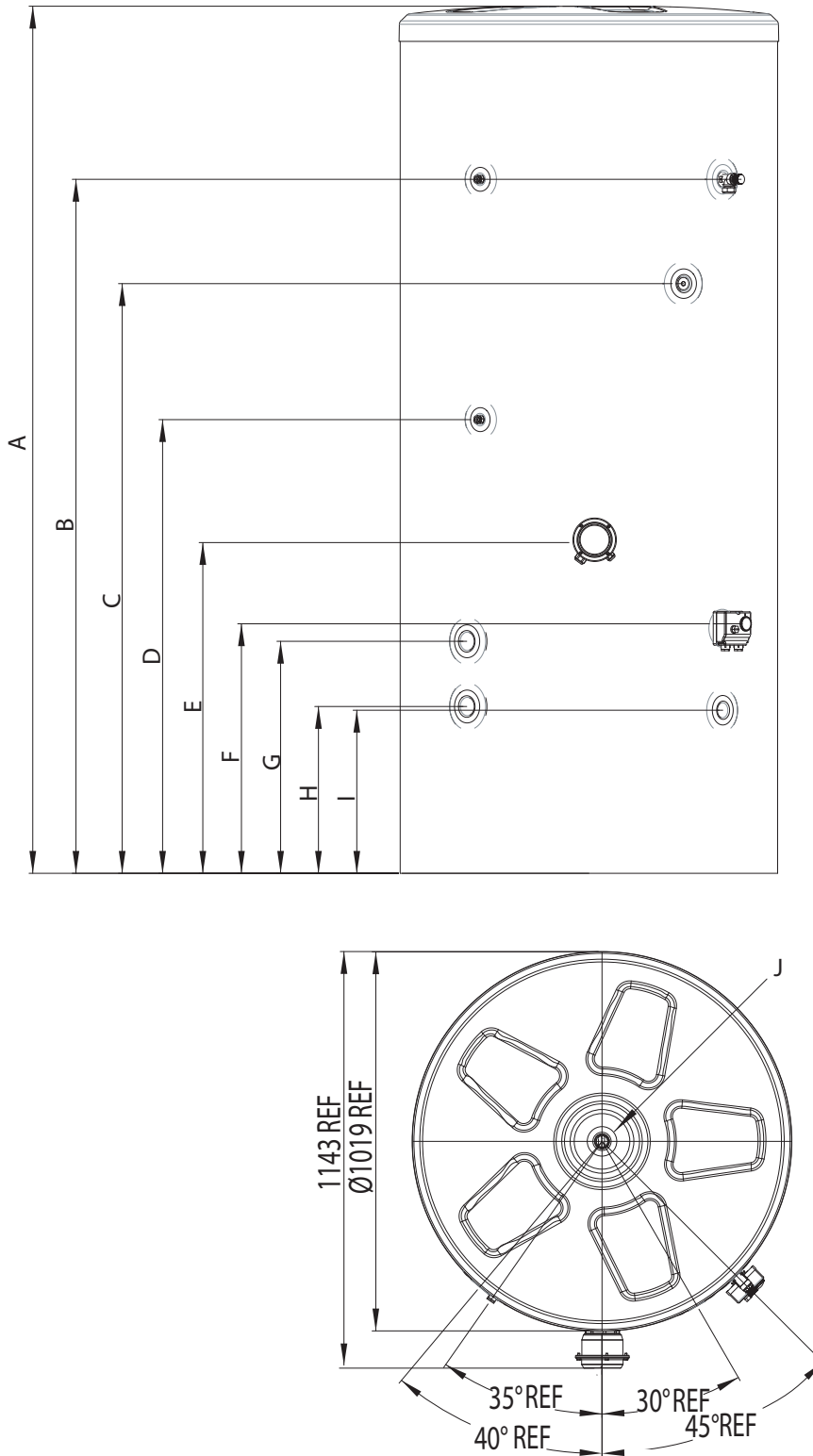

Figure 2: General dimensions - Indirect

Item	Connection	800l	1000l
A	N/A	1914	2327
B	1/2" BSP/T&P	1503	1886
C	1" BSP	1188	1583
D	1/2" BSP	1218	1438
E	1 3/4" BSP	888	888
F	1/2" BSP	710	710
G	1 1/4" BSP	623	623
H	1 1/4" BSP	448	448
I	1" BSP	438	438
J	2" BSP	N/A	N/A
K	2" BSP	N/A	N/A

Table 2: General dimensions table - Indirect

3.3 Electrical diagram(s)

Schematic Wiring Diagram - Basic 2 x 2 Port Valve System

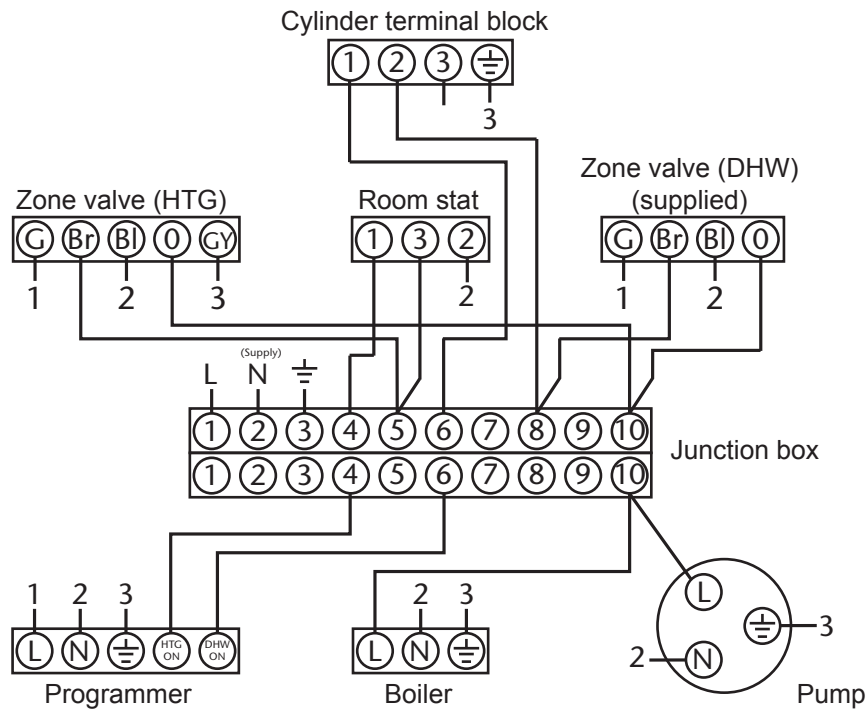

NOTES: Control terminal numbering may differ from those shown.
 Refer to instructions with controls selected.
 A double pole isolating switch must be installed in the mains supply.
 All earth connections must be connected back to the mains earth supply.

Figure 3: Schematic wiring diagram - basic 2 x 2 port valve system

Schematic Wiring Diagram - 3 Port Mid Position Valve System. N.B. Must Be Used In Conjunction With 2 Port Zone Valve Supplied

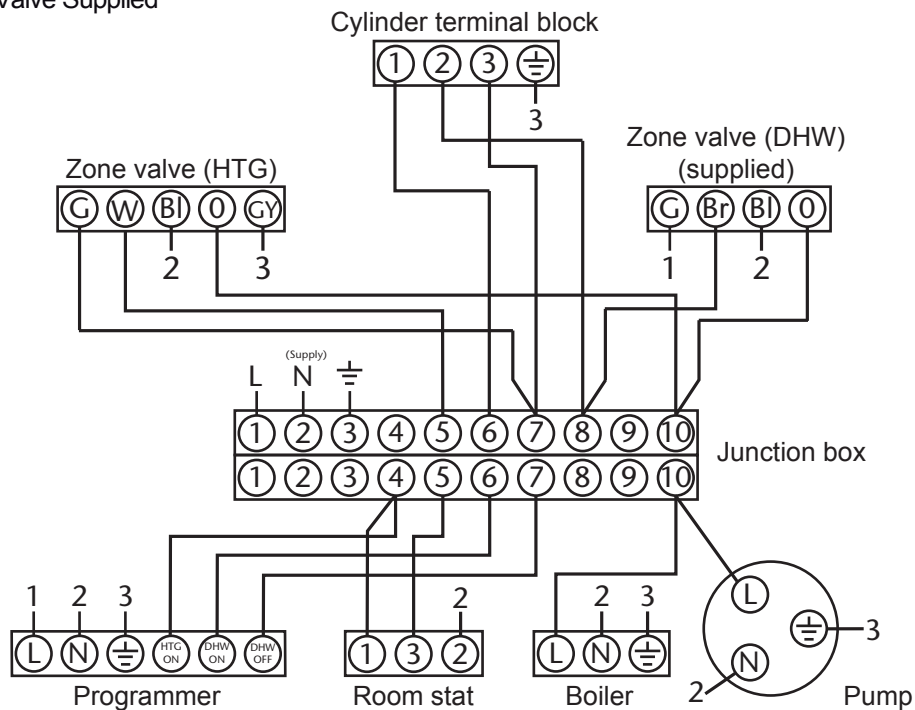

NOTES: Control terminal numbering may differ from those shown.
 Refer to instructions with controls selected.
 A double pole isolating switch must be installed in the mains supply.
 All earth connections must be connected back to the mains earth supply.

Figure 4: Schematic wiring diagram - 3 port mid position system

6kW immersion

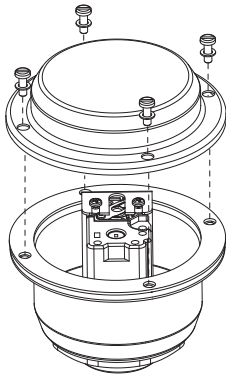

Step 1:

- remove 4 retaining screws and lift lid off immersion heater

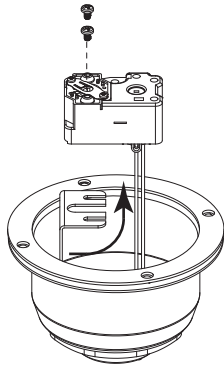

Step 2:

- remove 2 screws holding thermostatic controls and slide out thermostat from stat pocket.

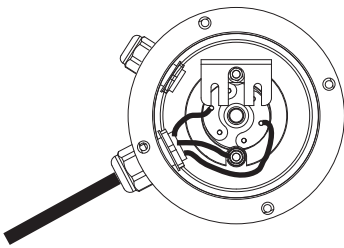

Step 3:

- Wire up immersion as per figures 6 or 7, page 9. If three phase wiring chosen remove "Live" side buzz bar and fit extra posts (supplied) to L1, L2 & L3. (outer case and bracket removed for clarity)

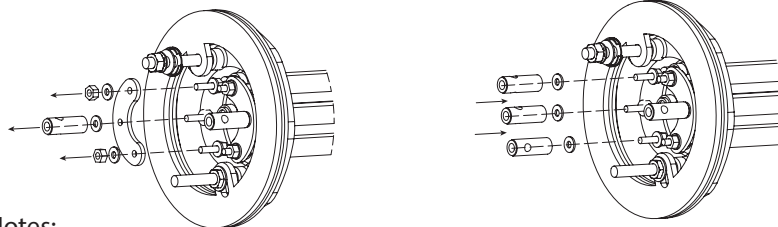

Notes:

For single phase wiring use 4mm² H07RNF 3 Core
 Use 2 x Two Pole 40A contactors for single phase
 For 3 phase use Five core 1mm² Fused at max 10A
 Use 2 x Three Pole 16A per pole contactors for 3 phase
 For signal wire use 5 core 1mm² Fused at max 6A for thermostat and thermal cut-out controls.

Disconnection time of the circuit protective device must be maintained below the regulatory minimum (in the UK 5 seconds for fixed equipment), cable sizes may have to be higher depending on the characteristics of the installation supply.

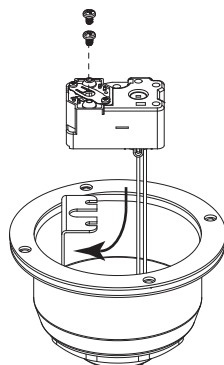

Step 4:

Replace thermostatic controls taking care when inserting the capillary bulbs into stat pocket and wire up as per figure 6 or 7, page 9.

Figure 5: Immersion head assembly

Single phase wiring schematic

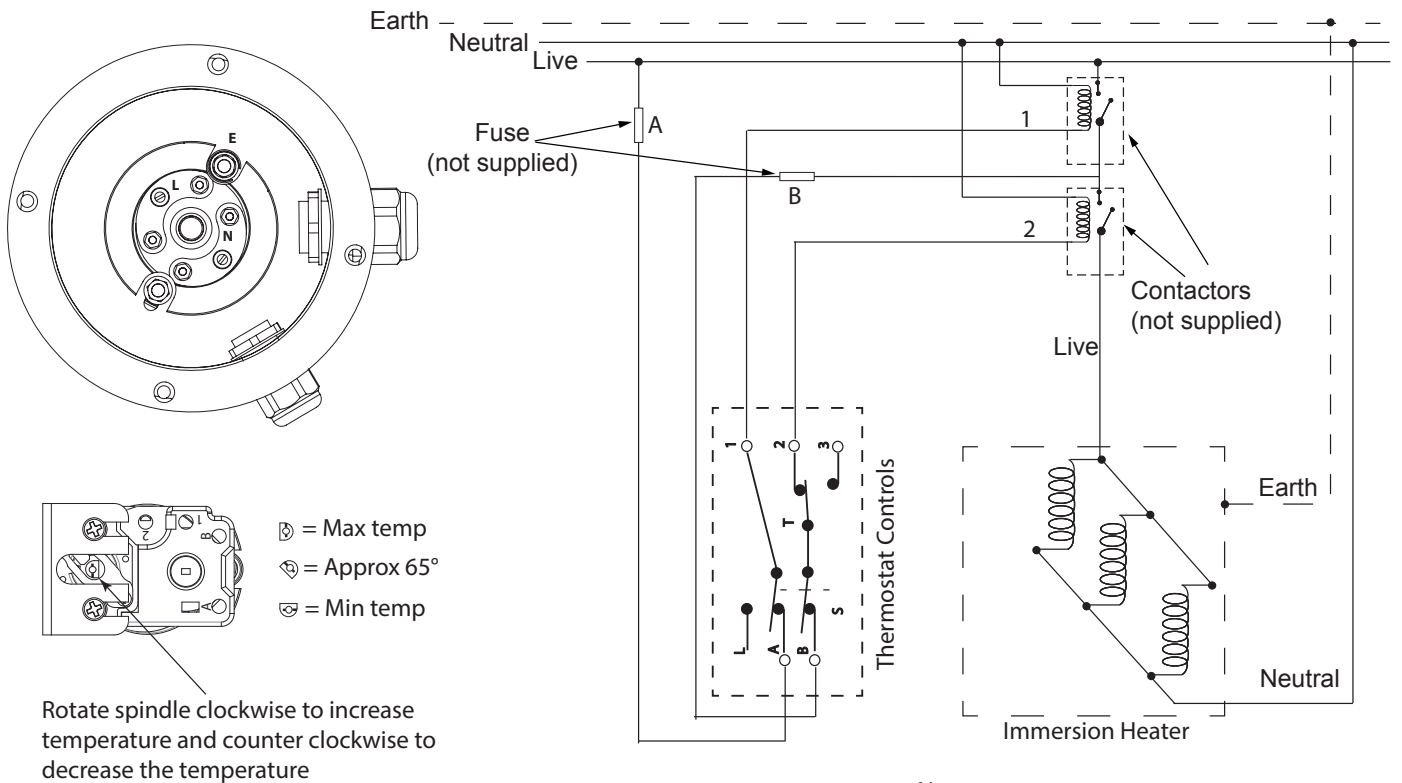

Note:
The 2 external contactors must be approved components certified for 10,000 cycles of operation for the contactor controlled by the thermostat and at least 30 for the contactor controlled by the non-self-resetting thermal cut-out.

Figure 6: Single phase wiring schematic

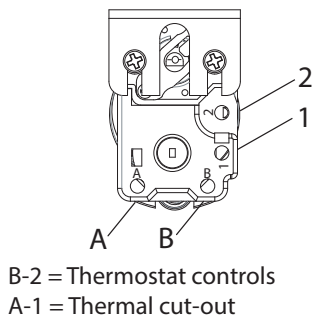

3 phase wiring schematic

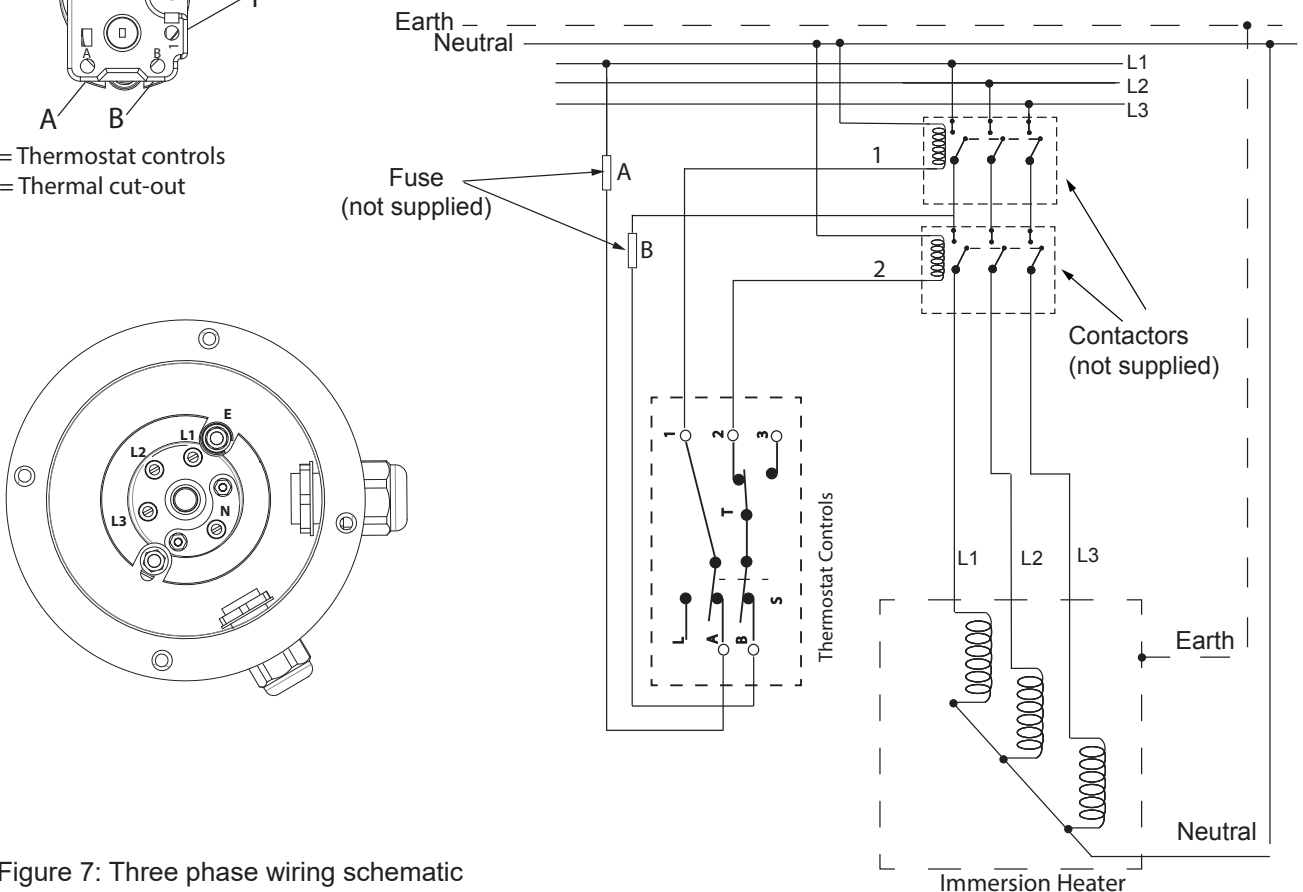

Figure 7: Three phase wiring schematic

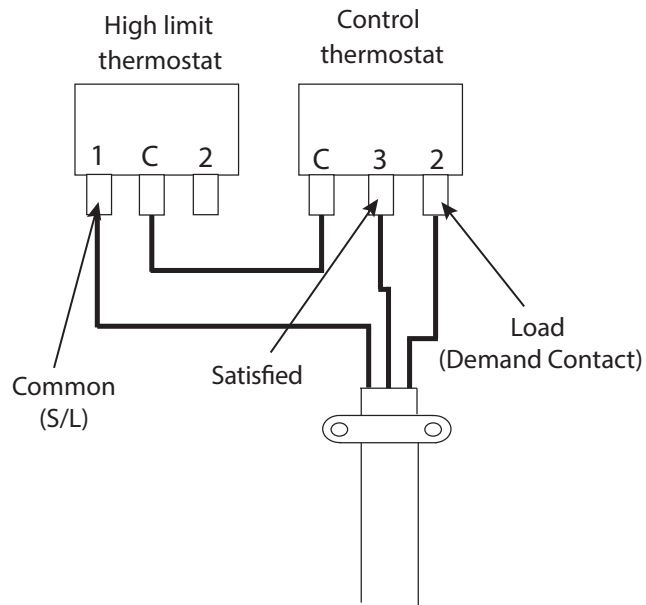
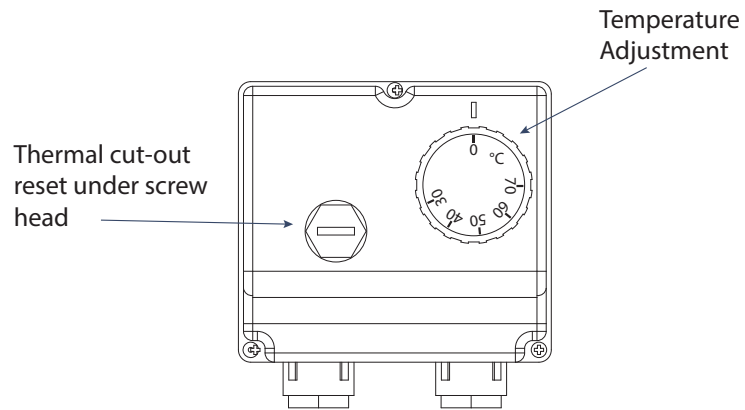

Figure 8: Indirect wiring schematic



4. Description of the product

4.1 General description

This product is a purpose designed unvented water heater. The unit has a stainless steel inner vessel, which ensures an excellent standard of corrosion resistance. The outer casing is a combination of resilient thermoplastic mouldings and soft jacket. All products are insulated with CFC free polyurethane foam (GWP 3.1) to give good heat loss protection.

The unit is supplied complete with all the necessary safety and control devices needed to allow connection to the cold water mains. All these components are preset and should not be tampered with.

4.2 Operation principle

The unvented cylinder is used to heat and store hot water for use in commercial applications.

The water is heated indirectly through a coil in the unit using an external heat source e.g. Gas, Oil or Electric. An Auxillary Immersion is also available

To provide pressure to the tap or shower an unvented unit uses the incoming mains water pressure. To do this the cylinder is sealed and not vented. However, when the volume of water is heated it expands and without any room for expansion could cause the cylinder to rupture and fail. To allow expansion of this heated water it is important that an expansion vessel is used. This vessel is pressurised and gives the heated water room to expand.

4.3 Main connections

See Figures 9 & 12: Main connections on page 15

4.4 Standard delivery

The delivery includes:

- ▶ Cylinder
- ▶ Literature pack
 - ▶ Instructions (inc benchmark commissioning checklist & service record)
- ▶ Cold water control pack
 - ▶ Expansion vessel
 - ▶ Combination valve (inc pressure reducing valve, pressure relief valve and check valve)
 - ▶ Tundish
- ▶ 2 port zone valve

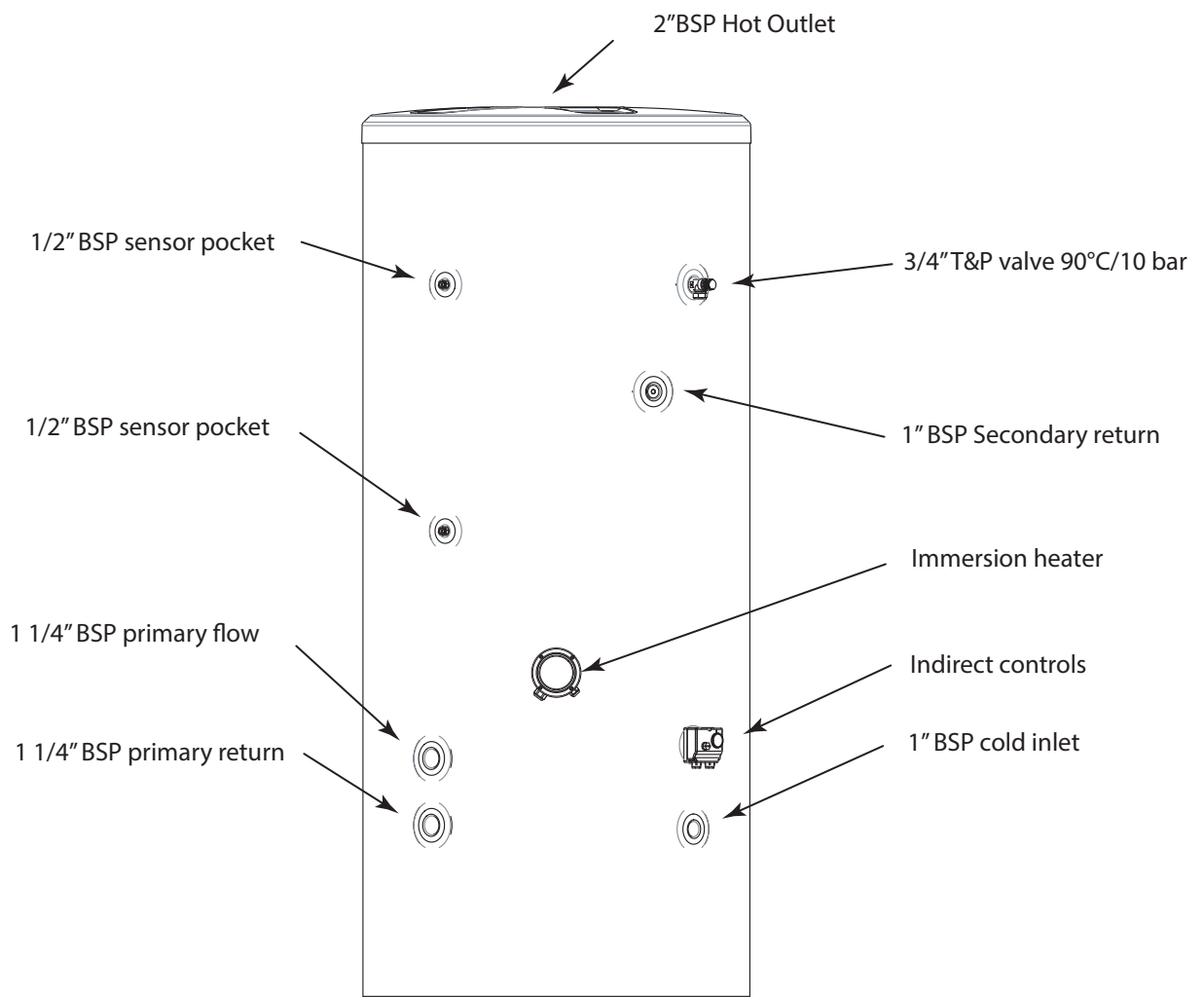

Figure 9: Indirect Cylinder

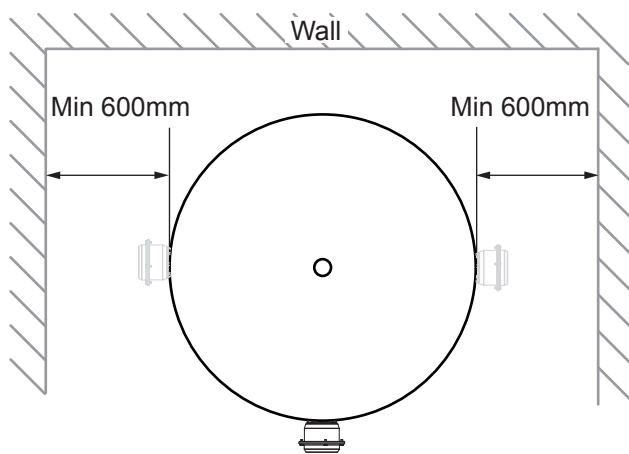

Figure 10: Siting the unit if immersions not at the front

5. Before installation

5.1 Installation regulations



WARNING

Installation of the appliance must be carried out by a qualified engineer in accordance with prevailing and national regulations as listed below.

- ▶ Building Regulations G3
- ▶ The Building Standards (Scotland)
- ▶ The Building Regulations (Northern Ireland)
- ▶ I.E.E Electrical Regs
- ▶ UK Water Regulations

5.2 Installation requirements

Water supply

In an unvented system the pressure and flowrate is directly related to the incoming water supply. For this reason it is recommended that the maximum water demand is assessed and the water supply checked to ensure this demand can be satisfactorily met.

- ▶ We suggest the minimum supply requirements should be 0.15MPa (1.5 bar) pressure and 100 litres per minute flow rate. However, at these values outlet flow rates may be poor if several outlets are used simultaneously.
- ▶ A 28mm cold water supply is recommended, however, if a smaller supply exists, which provides sufficient flow, this may be used (although more flow noise may be experienced).
- ▶ The higher the available pressure and flow rate the better the system performance.
- ▶ See table 1 & 2 on pages 5 & 6 for cylinder operating pressures. This is controlled by the cold water combination valve assembly.
- ▶ The water supply must be of wholesome water quality (Fluid Category 1 as defined by the Water Supply Regulations 1999).

Outlet/terminal fittings (taps, etc.)

- ▶ The cylinder can be used with most types of terminal fittings.
- ▶ Outlets situated higher than the cylinder will give outlet pressures lower than that at the heater, a 10m height difference will result in a 1 bar pressure reduction at the outlet.
- ▶ All fittings, pipework and connections must have a rated pressure of at least 8 bar (dependant on cylinder being fitted) at 80°C.

Limitations

The cylinder should not be used in association with any of the following:

- ▶ Solid fuel boilers or any other boiler in which the energy input is not under effective thermostatic control, unless additional and appropriate safety measures are installed.
- ▶ Ascending spray type bidets or any other class 1 back syphonage risk requiring that a type A air gap be employed.
- ▶ Steam heating plants unless additional and appropriate safety devices are installed.
- ▶ Situations where maintenance is likely to be neglected or safety devices tampered with.
- ▶ Water supplies that have either inadequate pressure or where the supply may be intermittent.
- ▶ Situations where it is not possible to safely pipe away any discharge from the safety valves.
- ▶ In areas where the water consistently contains a high proportion of solids, e.g. suspended matter that could block the strainer, unless adequate filtration can be ensured.
- ▶ In areas where the water supply contains chloride levels that exceed 250mg/l.

5.3 Choice of location

The cylinder must be vertically floor mounted. Although location is not critical, the following points should be considered:

- ▶ The cylinder should be sited to ensure minimum dead leg distances, particularly to the point of most frequent use.
- ▶ Avoid siting where extreme cold temperatures will be experienced. All exposed pipe work should be insulated.
- ▶ The discharge pipework from the safety valves must have minimum fall of 1:200 from the unit and terminate in a safe and visible position.
- ▶ Access to associated controls and immersion heaters must be available for the servicing and maintenance of the system. Where these controls are installed against a wall a minimum distance of 600mm must be left, see fig 10 page 12
- ▶ Ensure that the floor area for the cylinder is level and capable of permanently supporting the weight when full of water (see table 1, page 5 for weights).

5.4 Transport

Prior to installation the unit should be stored and transported in an area free from excessive damp or humidity. The unit should be stored in a frost free environment.

To aid installation, the water heater (800ltr upwards) is provided with lifting points located at the top of the unit. To access the lifting eyes please remove the top cover.

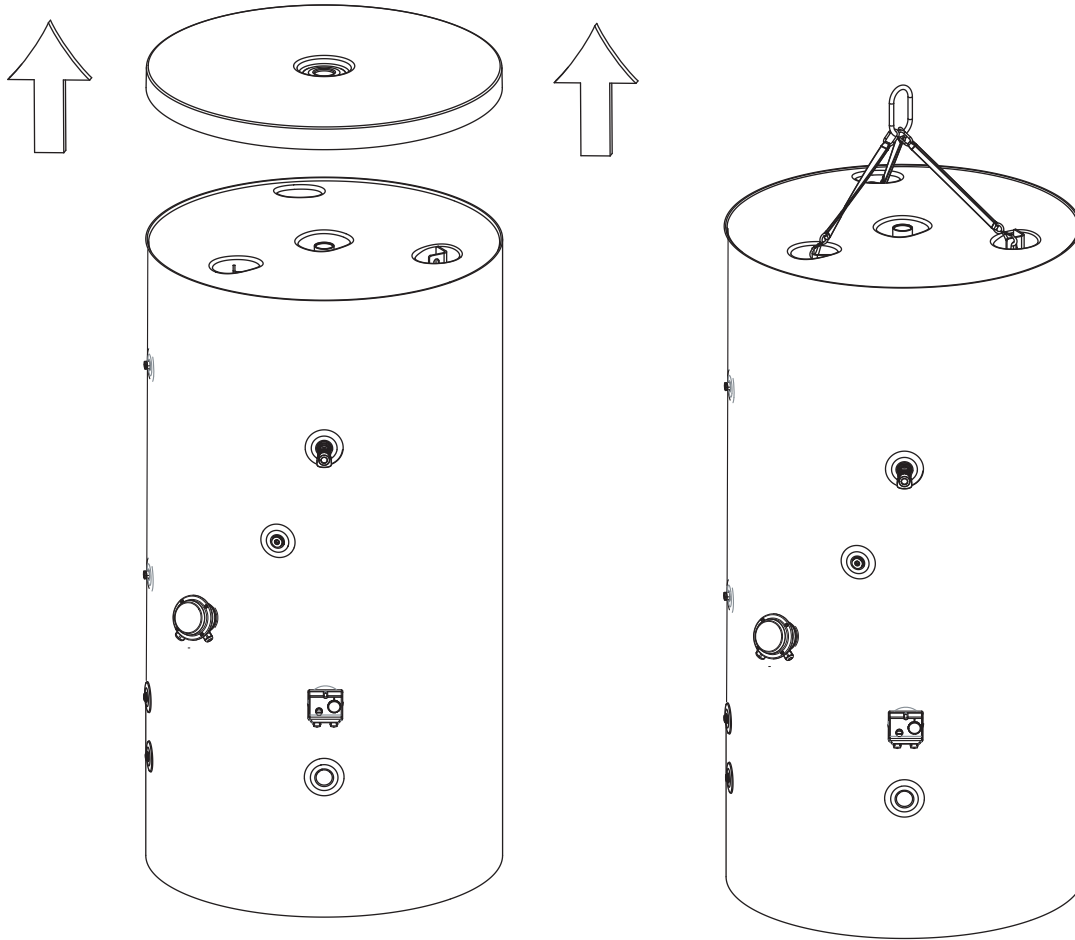

Figure 11: Lifting the unit

6. Installation

6.1 General

After reading the previous sections in this booklet and choosing a good location for the unit please install, paying attention to the following hydraulic, electrical and commissioning sections.

Boiler selection

- ▶ The boiler should have a control thermostat and non self-resetting thermal cut-out and be compatible with unvented storage water heaters.
- ▶ Where use of a boiler without a thermal cut-out is unavoidable a "low head" open vented primary circuit should be used. The feed and expansion cistern head above the cylinder should not exceed 2.5m.
- ▶ Can be a sealed system or open vented type - maximum primary pressure 3 bar (see Note 3 page 5).
- ▶ The boiler cannot be vented through the cylinder.

6.2 Water connections



WARNING

- ▶ Under no circumstances should the factory fitted temperature/pressure relief valve be removed other than by a competent person. To do so will invalidate any guarantee or claim.
- ▶ The cold water combination valve assembly must be fitted on the mains water supply to the cylinder.
- ▶ No control or safety valves should be tampered with or used for any other purpose.
- ▶ The discharge pipe should not be blocked or used for any other purpose.
- ▶ The tundish should not be located adjacent to any electrical components.

Refer to the installation schematic (fig 12, below) for details on the pipework layout. Specific details for the discharge pipework layout is also provided in figure 15 on page 20.

- ▶ All pipe fittings are made via BSP female pipe connections directly to the unit.
- ▶ A stopcock or servicing valve should be incorporated into the cold water supply to enable the cylinder and its associated controls to be isolated and serviced (not supplied).
- ▶ The expansion vessel must be connected between the cold water combination valve and the cylinder.

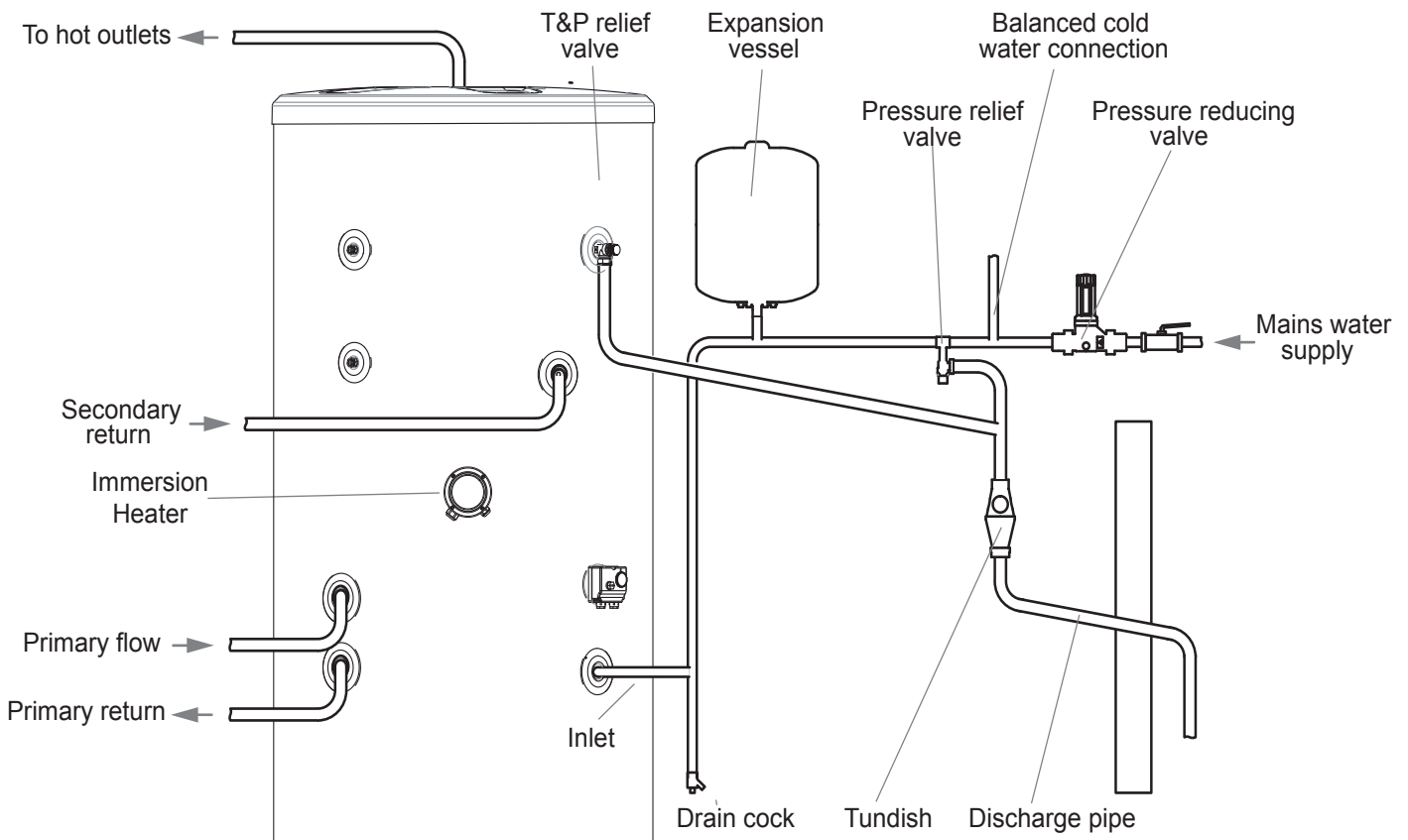

Figure 12: Typical installation schematic (not to scale)

- ▶ The location of the expansion vessel should allow access to recharge the pressure as and when necessary.
- ▶ A suitable draining tap should be installed in the cold water supply to the cylinder between the expansion valve and the heater at as low a level as possible.
- ▶ It is recommended that the outlet point of the drain pipework be at least 1 metre below the level of the heater (this can be achieved by attaching a hose to the drain tap outlet spigot).

Cold water control pack



CAUTION

- ▶ The expansion vessel pressure must be set in accordance with the inlet pressure set on the pressure reducing valve.
- ▶ Flush supply pipework before connection to remove all flux and debris prior to fitting the inlet controls. Failure to do this may result in irreparable damage to the controls and will invalidate any warranty.

- ▶ The cold water control pack can be connected anywhere on the cold water cylinder supply prior to the expansion vessel.
- ▶ The control pack incorporates the strainer, check valve, core unit and expansion relief valve.
- ▶ The pressure reducing valve is factory set to 3.5 bar and should not be adjusted.
- ▶ The valve can be fitted in any orientation to suit

the installation as long as the valve is installed with the direction of flow arrows pointing in the correct direction.

- ▶ The expansion relief valve should be installed with the discharge pipework in either the horizontal position or facing downwards.
- ▶ No other valves should be placed between the cold water combination valve and the cylinder.
- ▶ The blank plastic plugs in the body of the pressure relief valve are pressure gauge connections to enable pressure monitoring to be carried out, should the system develop a fault. It is recommended that these be accessible (the pressure reducing valve has two – only one need be accessible).
- ▶ Where discharge pipework is difficult to attain, the local building control officer from the local council should be sought for advice as this falls under G3 guidelines and is not down to the manufacturer for unvented systems.

Primary circuit control

- ▶ The 2 port motorised valve supplied with the cylinder **MUST** be fitted on the primary flow to the cylinder heat exchanger and wired such that in the event of the cylinder overheating it will close the primary circuit.
- ▶ Primary circulation to the cylinder heat exchanger must be pumped; gravity circulation **WILL NOT WORK**.
- ▶ It is recommended that an air bleed or automatic air vent is fitted to the highest point of the system.
- ▶ Boiler flow temperature should be set to 82° (maximum flow temperature to primary heat exchanger 89°C).

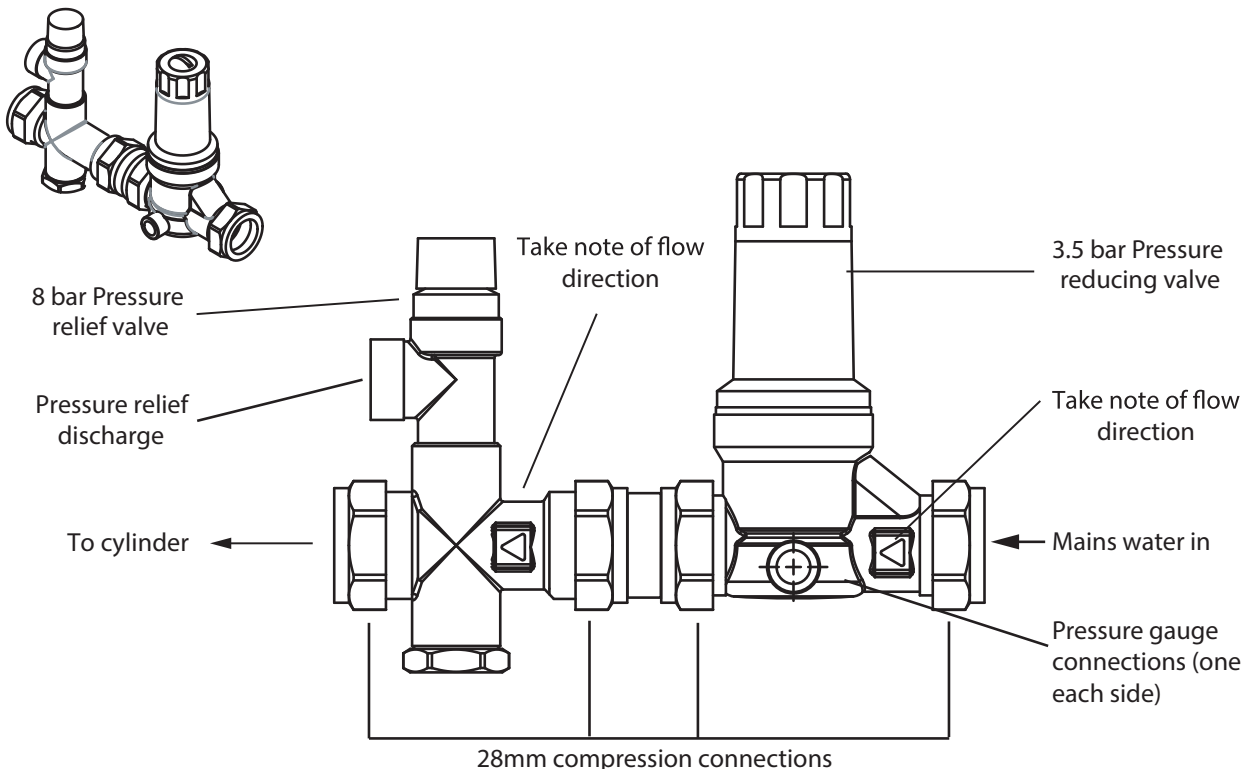

Figure 13: Cold water combination valve

Secondary circulation

If secondary circulation is required it is recommended that it be connected to the cylinder as shown (see fig. 14, below).

- ▶ The secondary return pipe should be in 28mm pipe and incorporate a check valve to prevent backflow.
- ▶ A suitable WRAS approved circulation pump will be required.
- ▶ On large systems, due to the increase in system water content, it may be necessary to fit an additional expansion vessel to the secondary circuit. This should be done if the capacity of the secondary circuit exceeds 10 litres.

Pipe capacity (copper):

15mm O.D. = 0.13 l/m (10 litres = 77m)

22mm O.D. = 0.38 l/m (10 litres = 26m)

28mm O.D. = 0.55 l/m (10 litres = 18m)

Note: Plastic pipe capacities may be reduced due to thicker wall sections.

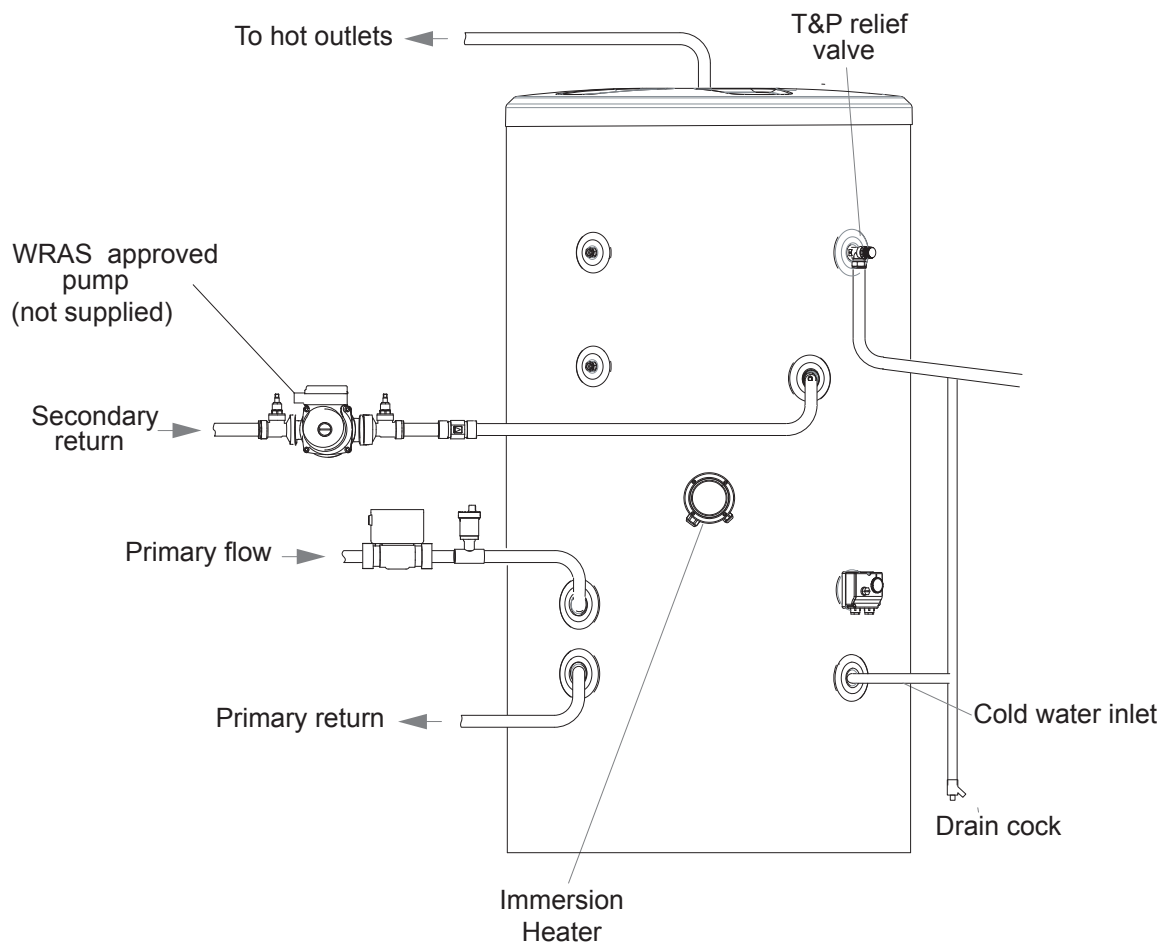

Figure 14: Secondary circulation schematic

Discharge

It is a requirement of Building Regulation G3 that any discharge from an unvented system is conveyed to where it is visible, but will not cause danger to persons in or about the building. The tundish and discharge pipes should be fitted in accordance with the requirements and guidance notes of Building Regulation G3. The G3 Requirements and Guidance section 3.50 - 3.63 are reproduced in the following sections of this manual. For discharge pipe arrangements not covered by G3 Guidance advice should be sought from your local Building Control Officer. Any discharge pipe connected to the pressure relief devices (expansion valve and temperature/pressure relief valve) must be installed in a continuously downward direction and in a frost free environment.

Water may drip from the discharge pipe of the pressure relief device. This pipe must be left open to the atmosphere. The pressure relief device is to be operated regularly to remove lime deposits and to verify that it is not blocked.

G3 REQUIREMENT

“...there shall be precautions...to ensure that the hot water discharged from safety devices is safely conveyed to where it is visible but will not cause danger to persons in or about the building.”

The following extract is taken from the latest G3 Regulations

Discharge pipes from safety devices

Discharge pipe D1

3.50 Each of the temperature relief valves or combined temperature and pressure relief valves specified in 3.13 or 3.17 should discharge either directly or by way of a manifold via a short length of metal pipe (D1) to a tundish.

3.51 The diameter of discharge pipe (D1) should be not less than the nominal outlet size of the temperature relief valve.

3.52 Where a manifold is used it should be sized to accept and discharge the total discharge from the discharge pipes connected to it.

3.53 Where valves other than the temperature and pressure relief valve from a single unvented hot water system discharge by way of the same manifold that is used by the safety devices, the manifold should be factory fitted as part of the hot water storage system unit or package.

Tundish

3.54 The tundish should be vertical, located in the same space as the unvented hot water storage system and be fitted as close as possible to, and lower than, the valve, with no more than 600mm of pipe between

the valve outlet and the tundish (see fig 15).

Note: To comply with the Water Supply (Water Fittings) Regulations, the tundish should incorporate a suitable air gap.

3.55 Any discharge should be visible at the tundish. In addition, where discharges from safety devices may not be apparent, e.g. in dwellings occupied by people with impaired vision or mobility, consideration should be given to the installation of a suitable safety device to warn when discharge takes place, e.g. electronically operated.

Discharge pipe D2

3.56 The discharge pipe (D2) from the tundish should:

- (a) have a vertical section of pipe at least 300mm long below the tundish before any elbows or bends in the pipework (see fig. 15); and*
- (b) be installed with a continuous fall thereafter of at least 1 in 200.*

3.57 The discharge pipe (D2) should be made of:

- (a) metal; or*
- (b) other material that has been demonstrated to be capable of safely withstanding temperatures of the water discharged and is clearly and permanently marked to identify the product and performance standard (e.g. as specified in the relevant part of BS 7291).*

3.58 The discharge pipe (D2) should be at least one pipe size larger than the nominal outlet size of the safety device unless its total equivalent hydraulic resistance exceeds that of a straight pipe 9m long, i.e. for discharge pipes between 9m and 18m the equivalent resistance length should be at least two sizes larger than the nominal outlet size of the safety device; between 18 and 27m at least 3 sizes larger, and so on; bends must be taken into account in calculating the flow resistance. See Fig 13, Table 3 and the worked example.

Note: An alternative approach for sizing discharge pipes would be to follow Annex D, section D.2 of BS 6700:2006 Specification for design, installation, testing and maintenance of services supplying water for domestic use within buildings and their curtilages.

3.59 Where a single common discharge pipe serves more than one system, it should be at least one pipe size larger than the largest individual discharge pipe (D2) to be connected.

3.60 The discharge pipe should not be connected to a soil discharge stack unless it can be demonstrated that the soil discharge stack is capable of safely withstanding temperatures of the water discharged, in which case, it should:

- (a) contain a mechanical seal, not incorporating a water trap, which allows water into the branch pipe without allowing foul air from the drain to be ventilated through the tundish;*

- (b) be a separate branch pipe with no sanitary appliances connected to it;
- (c) if plastic pipes are used as branch pipes carrying discharge from a safety device they should be either polybutylene (PB) to Class S of BS 7291-2:2006 or cross linked polyethylene (PE-X) to Class S of BS 7291-3:2006; and
- (d) be continuously marked with a warning that no sanitary appliances should be connected to the pipe.

Note:

1. Plastic pipes should be joined and assembled with fittings appropriate to the circumstances in which they are used as set out in BS EN ISO 1043-1.
2. Where pipes cannot be connected to the stack it may be possible to route a dedicated pipe alongside or in close proximity to the discharge stack.

Termination of discharge pipe

3.61 The discharge pipe (D2) from the tundish should terminate in a safe place where there is no risk to persons in the vicinity of the discharge.

3.62 Examples of acceptable discharge arrangements are:

- (a) to a trapped gully with the end of the pipe below a fixed grating and above the water seal;
- (b) downward discharges at low level; i.e. up to 100mm above external surfaces such as car parks, hard standings, grassed areas etc. are acceptable providing that a wire cage or similar guard is positioned to prevent contact, whilst maintaining visibility; and
- (c) discharges at high level: e.g. into a metal hopper and metal downpipe with the end of the discharge pipe clearly visible or onto a roof capable of withstanding high temperature discharges of water and 3m from any plastic guttering system that would collect such discharges.

3.63 The discharge would consist of high temperature water and steam. Asphalt, roofing felt and non-metallic rainwater goods may be damaged by such discharges.

Worked example of discharge pipe sizing

Fig. 15: shows a G1/2 temperature relief valve with a discharge pipe (D2) having 4 No. elbows and length of 7m from the tundish to the point of discharge.

From Table 3:

Maximum resistance allowed for a straight length of 22mm copper discharge pipe (D2) from a G1/2 temperature relief valve is 9.0m.

Subtract the resistance for 4 No. 22mm elbows at 0.8m each = 3.2m

Therefore the permitted length equates to: 5.8m

5.8m is less than the actual length of 7m therefore calculate the next largest size.

Maximum resistance allowed for a straight length of 28mm pipe (D2) from a G1/2 temperature relief valves equates to 18m.

Subtract the resistance of 4 No. 28mm elbows at 1.0m each = 4.0m

Therefore the maximum permitted length equates to: 14m

As the actual length is 7m, a 28mm (D2) copper pipe will be satisfactory.

Valve Outlet Size	Minimum Size Of Discharge Pipe D1	Minimum Size Of Discharge Pipe D2 From Tundish	Maximum Resistance Allowed, Expressed As A Length Of Straight Pipe (I.E. No Elbows Or Bends)	Resistance Created By Each Elbow Or Bend
G1/2	15mm	22mm 28mm 35mm	up to 9m up to 18m up to 27m	0.8m 1.0m 1.4m
G3/4	22mm	28mm 35mm 42mm	up to 9m up to 18m up to 27m	1.0m 1.4m 1.7m
G1	28mm	35mm 42mm 54mm	up to 9m up to 18m up to 27m	1.4m 1.7m 2.3m

Table 3: Sizing of copper discharge pipe (D2) for common temperature relief valve outlet sizes

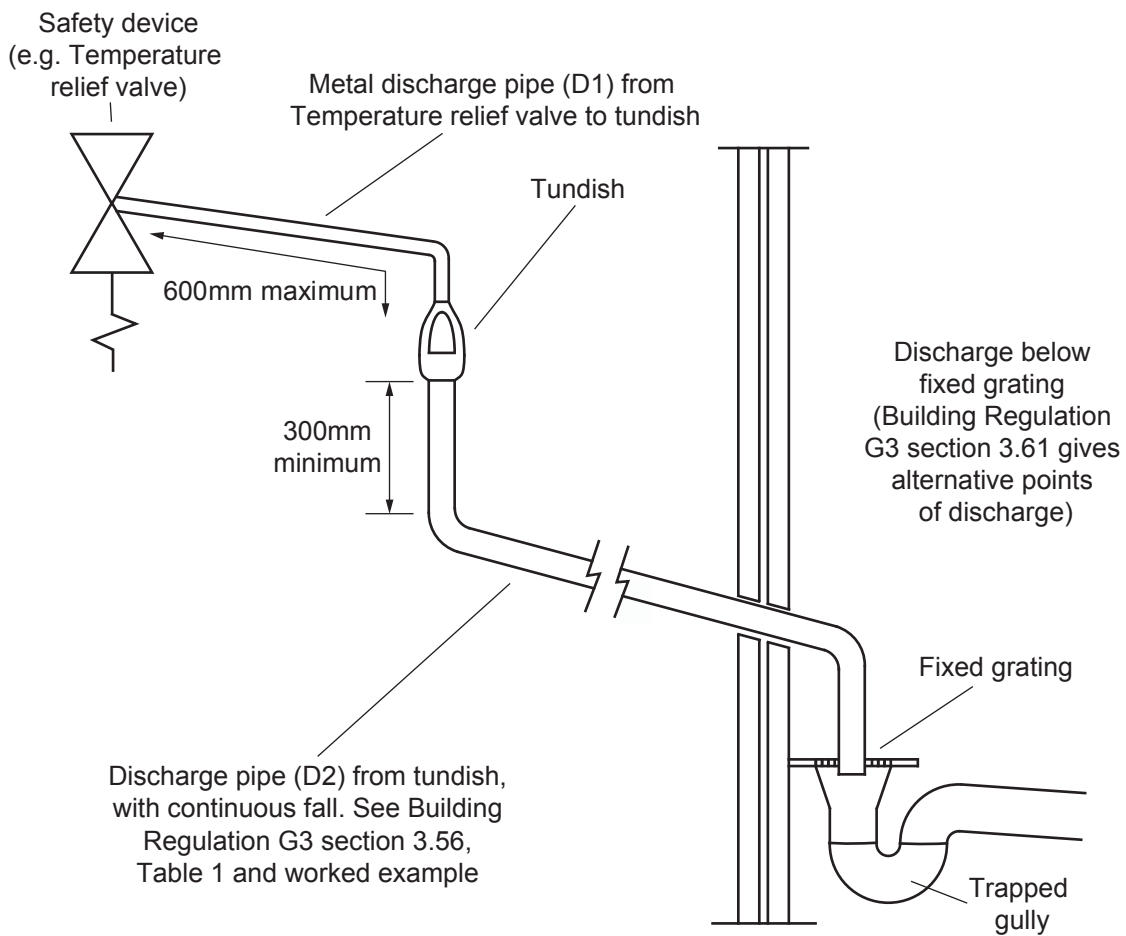

Figure 15: Typical discharge pipe arrangement (extract from Building Regulation G3 Guidance Section 3.50)

6.3 Electrical connections

In case of difficulty contact service support; contact details are available on page 34 of this booklet.



WARNING

- ▶ Disconnect from the mains electrical supply before removing any covers.
- ▶ Never attempt to replace the immersion heater(s) other than with genuine manufacturers components. Using other manufacturers components may invalidate the warranty on the cylinder.
- ▶ DO NOT bypass the thermal cut-out(s) in any circumstances. All electrical wiring should be carried out by a competent electrician and be in accordance with the latest I.E.E Wiring Regulations.
- ▶ Each circuit must be protected by a suitable fuse and double pole isolating switch with a contact separation of at least 3mm in both poles.
- ▶ DO NOT operate the immersion heaters until the cylinder has been filled with water.

- ▶ The immersion heater should be wired in accordance with fig's 6 & 7, page 09.

Space and heating systems controls

- ▶ The controls provided with the cylinder will ensure the safe operation of the unit within the central heating system. Other controls will be necessary to control the space heating requirements and times that the system is required to function.
- ▶ The cylinder is compatible with most heating controls, examples of electrical circuits are shown in figs. 3 and 4, page 7. However, other systems may be suitable, refer to the controls manufacturers instructions, supplied with the controls selected, for alternative system wiring schemes.

6.4 Filling the installation

- ▶ Check expansion vessel pre-charge pressure. The expansion vessel pressure must be set in accordance with the inlet pressure set on the pressure reducing valve.
- ▶ Ensure the drain cock is CLOSED.
- ▶ Open a hot tap furthest from the cylinder.
- ▶ Open the mains stop cock to fill the unit. When water flows from the tap, allow to run for a few minutes to thoroughly flush through any residue, dirt or swarf, then close the tap.
- ▶ Open successive hot taps to purge the system of air.

7. Commissioning

7.1 General

After filling the installation with water in the previous section please follow the following steps to complete the installation of the unit.



WARNING

- ▶ DO NOT operate the immersion heaters or primary circuit until the cylinder has been filled with water.
- ▶ WARNING: If the unit is to be left unused following installation and commissioning, e.g. unoccupied properties, the water heater should be drained or regularly flushed through with fresh mains water once a week.
- ▶ When placing the unit into service, the procedure for filling the unit and the system checks above should be observed.

7.2 Checklist before commissioning

- ▶ Check all water connections for leaks and rectify as necessary.
- ▶ Turn off mains water supply.
- ▶ Remove the pressure reducing valve head work to access the strainer mesh, clean and re-fit.
- ▶ Turn the water supply back on.
- ▶ Manually open, for a few seconds, each relief valve in turn, checking that water is discharged and runs freely through the tundish and out at the discharge point.
- ▶ Ensure that the valve(s) reseat satisfactorily.

7.3 Commissioning procedure

- ▶ Fill the indirect (primary) circuit following the boiler manufacturer's commissioning instructions.
- ▶ To ensure the cylinder primary heat exchanger is filled, the 2 port motorised valve (supplied) should be manually opened by moving the lever on the motor housing to the MANUAL setting. When the primary circuit is full return the lever to the AUTOMATIC position.
- ▶ Switch on the boiler, ensure the programmer is set to Hot Water and allow the cylinder to heat up to a normal working temperature 65°C (recommended).

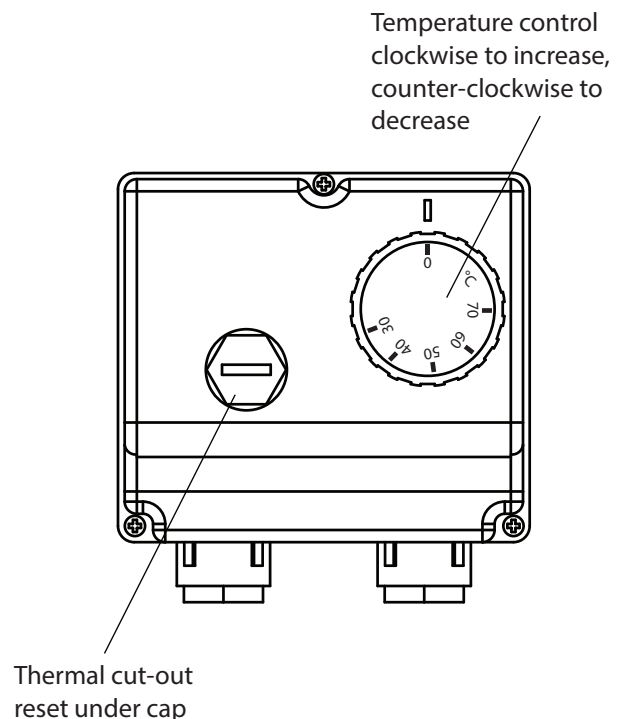

Figure 16: Indirect controls

8. Operation

8.1 General



WARNING

- ▶ If water discharges from the temperature/pressure relief valve on the cylinder shut down the heat source. Do not turn off any water supply. Contact a competent installer for unvented water heaters to check the system.
- ▶ Do not tamper with any of the safety valves fitted to the system. If a fault is suspected contact a competent installer.
- ▶ DO NOT bypass the thermal cut-out(s) in any circumstances.

Benchmark

The cylinder is covered by the Benchmark Scheme which aims to improve the standards of installation and commissioning of domestic heating and hot water systems in the UK and to encourage regular servicing to optimise safety, efficiency and performance.

Benchmark is managed and promoted by the Heating and Hotwater Industry Council. For more information visit www.centralheating.co.uk.

Please ensure that the installer has fully completed the Benchmark Checklist (page 30 & 31) of this manual and that you have signed it to say that you have received a full and clear explanation of its operation. The installer is legally required to complete a commissioning checklist as a means of complying with the appropriate Building Regulations (England & Wales).

All installations must be notified to Local Area Building Control either directly or through a Competent Persons Scheme. A Building Regulations Compliance Certificate will then be issued to the customer who should, on receipt, write the Notification Number on the Benchmark Checklist.

This product should be serviced regularly to optimise its safety, efficiency and performance. The service engineer should complete the relevant Service Record on the Benchmark Checklist after each service.

The Benchmark Checklist may be required in the event of any warranty work.

Flow performance

When initially opening hot outlets a small surge in flow may be noticed as pressures stabilise. This is quite normal with unvented systems. In some areas cloudiness may be noticed in the hot water. This is due to aeration of the water, is quite normal and will quickly clear.

Temperature controls – Auxillary immersion heater(s)

- ▶ All immersion heaters are fitted with a thermostat which is fitted in the centre of the heater plate and a cut-out which is fitted to the side of the thermostat.
- ▶ Access to the thermostat can be made by opening the immersion heater cover - DISCONNECT THE ELECTRICAL SUPPLY BEFORE OPENING THE COVER(S).
- ▶ Temperature adjustment is made by rotating the adjustment spindle on the top of the thermostat. The adjustment represents a temperature range of 15°C to 74°C.
- ▶ Maximum working temperature is 74°C/165°F. In very hard water areas limit to 60/65°C (140/150°F).

DO NOT bypass the thermal cut-out(s) in any circumstances.

Temperature controls - indirect units

The cylinder units are fitted with an indirect thermostat and thermal cut-out. These controls must be wired in series with the 2 port motorised zone valve supplied to interrupt the flow of primary water around the heat exchanger coil when the control temperature has been reached.

DO NOT bypass the thermal cut-out(s) in any circumstances.

Operational faults

Operational faults and their possible causes are detailed in the Fault Finding section (p.28) of this book. It is recommended that faults should be checked by a competent installer.

The air volume within the expansion vessel will periodically require recharging to ensure expanded water is accommodated within the system. A discharge of water **INTERMITTENTLY** from the expansion valve will indicate the air volume has reduced to a point where it can no longer accommodate the expansion. This will require a suitably qualified person to check the expansion vessel pressure and no attempt should be made to re-pressurize the expansion vessel by the end user.

9. Maintenance

9.1 General

Maintenance requirements

Unvented hot water systems have a continuing maintenance requirement in order to ensure safe working and optimum performance. It is essential that the relief valve(s) are periodically inspected and manually opened to ensure no blockage has occurred in the valves or discharge pipework. Maintenance of this appliance should only be carried out by a suitably qualified person. Failure to do so could invalidate the warranty.

Similarly cleaning of the strainer element and replacement of the air in the expansion vessel will help to prevent possible operational faults.

The maintenance checks described below should be performed by a competent person on a regular basis, e.g. annually to coincide with boiler maintenance.

After any maintenance, please complete the relevant Service Interval Record section of the Benchmark Checklist on page 32 of this document.

9.2 Standard inspection & maintenance operations

Inspection

The immersion heater boss can be used as an access for inspecting the cylinder internally.

Safety valve operation



CAUTION

Water discharged may be very hot!

- ▶ Manually operate the temperature/pressure relief valve for a few seconds.
- ▶ Check water is discharged and that it flows freely through the tundish and discharge pipework.
- ▶ Check valve reseats correctly when released.
- ▶ Repeat the above procedure for the expansion relief valve.

Strainer

- ▶ Turn off the isolating valve prior to the Pressure Reducing Valve or the main stop cock to the system.
- ▶ Open the lowest hot tap in the system to relieve the system pressure.
- ▶ Using a spanner unscrew the pressure reducing cartridge and remove the moulded housing. The strainer will be removed with the cartridge.
- ▶ Wash any particulate matter from the strainer under clean running water.
- ▶ Replace the strainer and screw the Pressure Reducing Valve cartridge into the moulded housing.
- ▶ Close hot tap, turn on isolating valve or main stop cock to the system. Check for leaks.

Descaling immersion heater(s)

- ▶ Turn off the mains water supply, isolate the electrical supply and turn off boiler
- ▶ Attach a hosepipe to the drain cock having sufficient length to take water to a suitable discharge point below the level of the unit.
- ▶ Open a hot tap close to the unit and open drain cock to drain unit.
- ▶ Open the cover(s) to the immersion heater housing(s) and disconnect wiring from immersion heater(s) thermostat(s).
- ▶ Unscrew the immersion heater and withdraw the immersion heater from the cylinder. Take care when lifting the immersion heater out of the cylinder and work within safe working practices.
- ▶ Carefully remove any scale from the surface of the element(s).



CAUTION

DO NOT use a sharp implement as damage to the element surface could be caused.

- ▶ Ensure sealing surfaces are clean and seals are undamaged, if in doubt fit a new "O" ring. (spare part number 95611810)
- ▶ Replace immersion heater(s), making sure not to trap the "O" ring.
- ▶ Rewire, check, close and secure immersion heater housing cover(s).

Expansion vessel charge pressure

- ▶ Remove the dust cap on top of the vessel.
- ▶ De-pressurise the system by turning the mains supply off and then opening a hot tap.
- ▶ Check the charge pressure using a tyre pressure gauge. The pressure must be set in accordance with the inlet pressure set on the pressure reducing valve.
- ▶ If it is lower than the required setting it should be re-charged using a tyre pump (Schrader valve type).



CAUTION

DO NOT OVER-CHARGE

- ▶ Re-check the pressure and when correct replace the dust cap.

Re-commissioning

- ▶ Check all electrical and plumbing connections are secure. Close the drain cock.
- ▶ With a hot tap open, turn on the cold water supply and allow unit to refill.
- ▶ DO NOT switch on the immersion heater(s) or boiler until the unit is full.
- ▶ When water flows from the hot tap allow to flow for a short while to purge air and flush through any disturbed particles.
- ▶ Close hot tap and then open successive hot taps in system to purge any air.
- ▶ When completely full and purged check system for leaks.
- ▶ The heating source (immersion heater(s) or boiler) can then be switched on.

10. Troubleshooting



WARNING

Do not tamper with any of the safety valves or controls supplied with the cylinder as this will invalidate any guarantee.

10.1 Fault finding

Important

- ▶ After servicing, complete the relevant Service Interval Record section of the Benchmark Checklist located on pages 30 and 31 of this document.
- ▶ Servicing should only be carried out by competent persons in the installation and maintenance of unvented water heating systems.
- ▶ Any spare parts used **MUST** be authorised parts.
- ▶ Disconnect the electrical supply before removing any electrical equipment covers.
- ▶ **NEVER** bypass any thermal controls or operate system without the necessary safety valves.

- ▶ Water contained in the cylinder may be very hot, especially following a thermal control failure. Caution must be taken when drawing water from the unit.

The fault finding chart (table 4, below) will enable operational faults to be identified and their possible causes rectified. Any work carried out on the unvented water heater and its associated controls **MUST** be carried out by a competent installer for unvented water heating systems. In case of doubt contact service support.

Spare Parts

A full range of spare parts are available for the cylinder range (table 5, page 28). Refer to the technical data label on the unit to identify the model installed and ensure the correct part is ordered. You will need to quote the serial number, which is printed on the data label.

Fault	Possible Cause	Remedy
No hot water flow	Mains supply off	Check and open stop cock
	Strainer blocked	Turn off water supply. Remove strainer and clean
	Cold water combination valve incorrectly fitted	Check and refit as required
Water from hot tap is cold	Indirect programmer set to central heating only	Check, set to domestic hot water programme
	Indirect boiler not working	Check boiler operation. If fault is suspected consult boiler manufacturer's instructions
	Indirect thermal cut-out has operated	Check, reset by pushing button on thermostat. Check operation of indirect thermostat
	Indirect motorised valve not connected correctly	Check wiring and/or plumbing connections to motorised valve
Water discharges from expansion valve	Intermittently Expansion vessel charge pressure has reduced below 3.5 bar, or set too high	See Maintenance section (p.19) for re-charging of expansion vessel procedure
	Continually Cold water combination valve pressure reducer not working correctly. Expansion valve seat damaged	Check pressure from cold water combination valve. If greater than 3.5 bar replace pressure reducing valve cartridge. Remove expansion valve cartridge, check condition of seat. If necessary fit new expansion valve
Water discharges from T&P relief valve	Thermal control failure CAUTION: Water will be very hot!	Switch off power to immersion heater(s) and shut down boiler. DO NOT turn off water supply. When discharge stops check all thermal controls, replace if faulty
Milky water	Oxygenated water	Water from a pressurised system releases oxygen bubbles when flowing. The milkiness will disappear after a short while

Table 4: Fault finding chart

11. Decommissioning

11.1 Decommissioning procedure

- ▶ Isolate electrical supplies and make safe
- ▶ Isolate the water supply
- ▶ Drain the cylinder
- ▶ Drain the primary circuit
- ▶ Remove cylinder
- ▶ Cap pipework

Environmental information

Products are manufactured from many recyclable materials. At the end of their useful life they should be disposed of at a Local Authority Recycling Centre in order to realise the full environmental benefits.

Insulation is by means of an approved CFC/HCFC free polyurethane foam with an ozone depletion factor of zero.

WEEE Declaration

Disposal of Waste Equipment by Users in Private Household in the European Union.



This symbol on the product indicates that this product must not be disposed of with your other household waste. Instead, it is your responsibility to dispose of your waste equipment by handing it over to a designated collection point for the recycling of waste electrical equipment. The separate collection and recycling of your waste equipment at the time of disposal will help to conserve natural resources and ensure that it is recycled in a manner that protects human health and the environment. For more information about where you can drop off your waste equipment for recycling, please contact your local city office, your household waste disposal service or the company where this product was purchased.

Insulation is by means of an approved CFC/HCFC free polyurethane foam with an ozone depletion factor of zero.

12. Spare parts

12.1 Spare parts list

A full range of spare parts are available for the cylinder range. Refer to the Technical Data label on the unit to identify the model installed and ensure the correct part is ordered.

	DESCRIPTION	SPARES NUMBER
1	Integrated inlet control valve set (28mm)	95605104
2	Pressure reducing valve (3.5 bar, 28mm)	95605105
3	Pressure relief valve (8 bar, 28mm)	95605107
4	Pressure relief cartridge	95605108
5	6 kW Immersion heater (1 3/4" screw thread)	95602001
6	Dual temperature and thermal cut-out (Immersion heater)	95612064
7	Dual temperature and thermal cut-out (Indirect)	95612650
8	Immersion Heater "O" ring	95611810
9	3/4" Temperature/Pressure relief valve	95605103
10	Expansion vessel (60L)	95607445
11	Tundish (22mm - 28mm)	7716580
12	2 port motorised valve (28mm)	95605884
13	1/2" Blanking stat pocket	95607690
14	Isolating ball valve 1"	95605178
15	Isolating drain valve 1"	95605182

Table 5: Spares

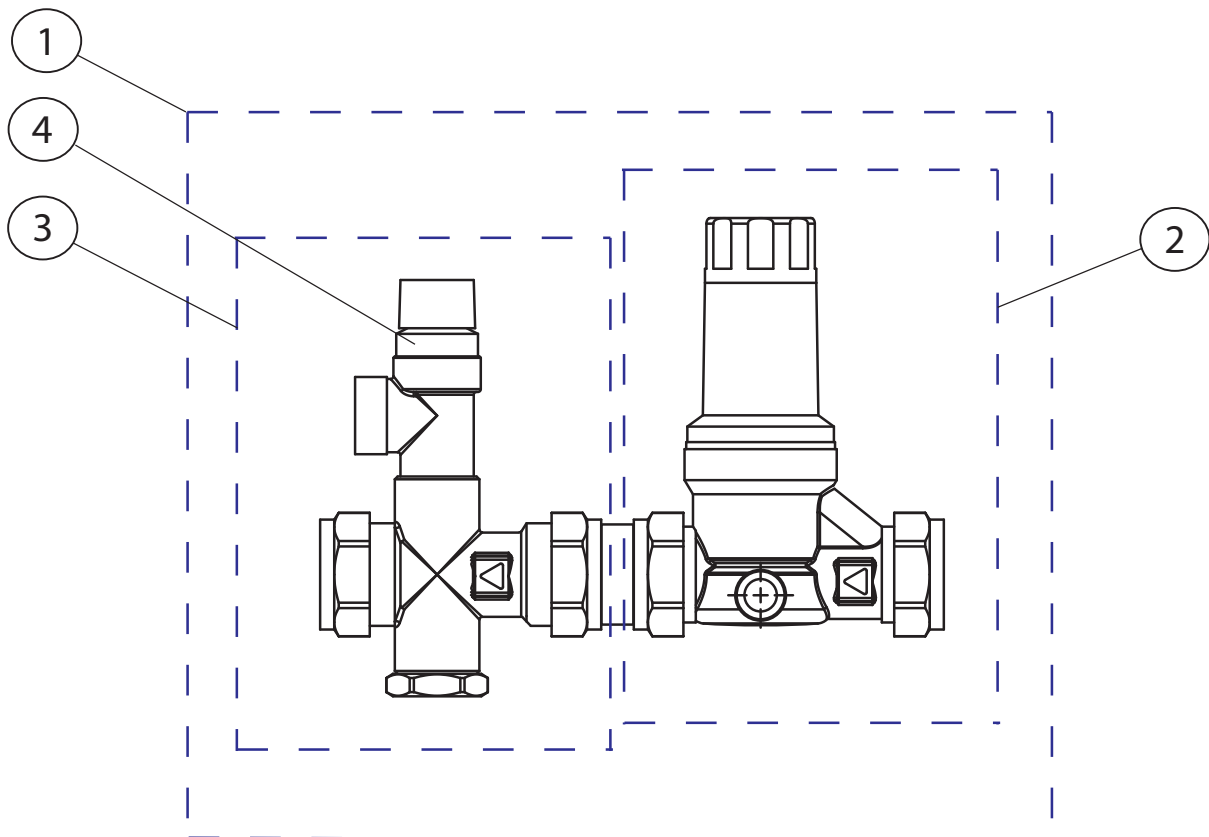

Figure 18: Integrated control valve set

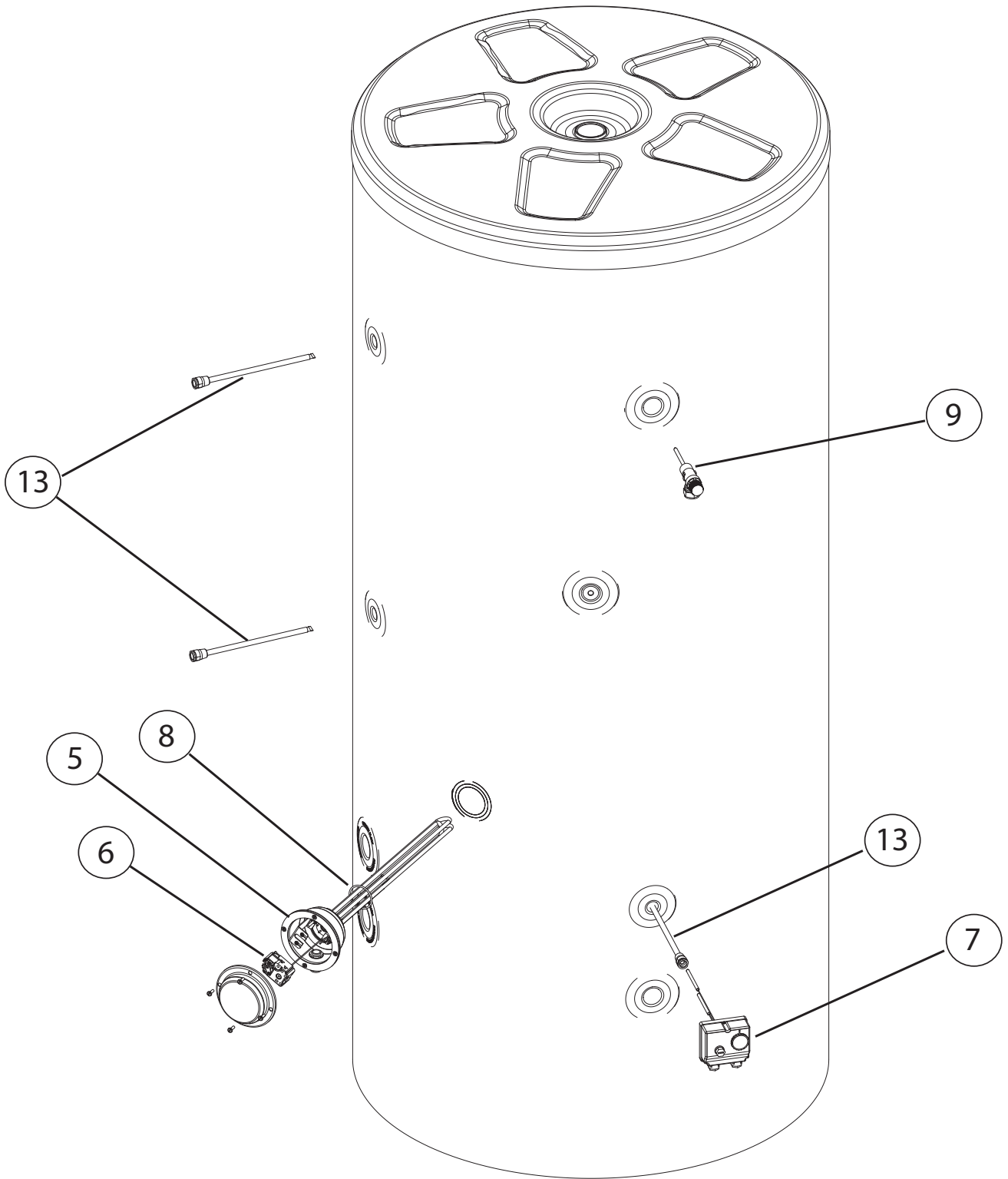

Figure 19: Exploded spares diagram.

SERVICE RECORD

Commissioning & service records

It is recommended that your hot water system is serviced regularly and that the appropriate Service Record is completed.

Service Provider

Before completing the appropriate Service Record below, please ensure you have carried out the service as described in the manufacturer's instructions.

SERVICE 1 Date _____
Engineer Name _____
Company Name _____
Telephone Number _____
Comments _____

Signature _____

SERVICE 2 Date _____
Engineer Name _____
Company Name _____
Telephone Number _____
Comments _____

Signature _____

SERVICE 3 Date _____
Engineer Name _____
Company Name _____
Telephone Number _____
Comments _____

Signature _____

SERVICE 4 Date _____
Engineer Name _____
Company Name _____
Telephone Number _____
Comments _____

Signature _____

SERVICE 5 Date _____
Engineer Name _____
Company Name _____
Telephone Number _____
Comments _____

Signature _____

SERVICE 6 Date _____
Engineer Name _____
Company Name _____
Telephone Number _____
Comments _____

Signature _____

SERVICE 7 Date _____
Engineer Name _____
Company Name _____
Telephone Number _____
Comments _____

Signature _____

SERVICE 8 Date _____
Engineer Name _____
Company Name _____
Telephone Number _____
Comments _____

Signature _____

SERVICE 9 Date _____
Engineer Name _____
Company Name _____
Telephone Number _____
Comments _____

Signature _____

SERVICE 10 Date _____
Engineer Name _____
Company Name _____
Telephone Number _____
Comments _____

Signature _____

Lifetime Warranty*

The Megaflo Lifetime Warranty provides unrivalled levels of customer support and peace of mind in the unlikely event that a problem arises from a manufacturing defect. It is supported by a large nationwide team of company-employed field-based engineers and our own call centre, which is open 363 days a year.

This Lifetime Warranty applies in relation to the following Megaflo products:

- Megaflo cylinders
- Megaflo calorifiers

The Megaflo Domestic Lifetime* Warranty

The Megaflo Domestic Lifetime* Warranty covers Megaflo cylinders installed in domestic properties† against corrosion for the lifetime* of the owner.

The cold water combination valve (and expansion vessel, where supplied) is covered by a five year warranty from the date of purchase of the Megaflo product that includes both parts and labour. All other components, including any other valves, fittings and controls are covered by a two year warranty from the date of purchase of the Megaflo product that includes both parts and labour.

In the case of the Megaflo Systemready, Megaflo Systemfit and Megaflo SolaReady units the supplied pumps and motorized valves (where fitted) are also covered by this two year warranty.

Incalloy immersion heaters (where fitted) are covered by a two year warranty.

Titanium Immersion heaters (where fitted) are covered by a five year warranty.

The Megaflo Commercial Lifetime* Warranty

The Megaflo Commercial Lifetime Warranty covers Megaflo cylinders and calorifiers installed in non-domestic properties^ against corrosion for a period of 30 years from the date of purchase.

All other components, including valves, expansion vessels, immersion heaters, fittings and controls are covered by a two year warranty from the date of purchase of the Megaflo product that includes both parts and labour.

Accessories

Shower heat recovery units are covered against manufacturing defects for a period of two years. Flat plate solar collectors are covered against manufacturing defects for a period of 10 years from the date of purchase of the Megaflo product. Evacuated tube solar collectors are covered against manufacturing defects for a period of five years from the date of purchase of the Megaflo product. All other solar accessories are covered against manufacturing defects for a period of two years from the date of purchase of the Megaflo product.

Outside of the UK

These warranties are valid for installations within the United Kingdom.

For installation in the Republic of Ireland please contact Baxi Potterton Myson (Ireland) Limited on 00353 (0) 1 4590870

For installations outside of the United Kingdom and the Republic of Ireland, please telephone Megaflo Export on +44 1603 420271 for further details of the warranty terms and conditions applicable.

These guarantees are valid provided that:

- The Megaflo product has been installed by a competent installer in accordance with the instructions contained in the installation instructions and in compliance with all relevant laws, guidance, codes of practice and regulations in force at the time of installation.
- The Megaflo product has not been modified or tampered with in any way, other than by a Heatrae Sadia or Baxi Customer Support approved engineer.
- The Megaflo product has not been subject to damage by scale.
- The Megaflo product and any part or parts of the Megaflo product (whether factory fitted or otherwise) have not been repaired or replaced other than by a Baxi Customer Support approved engineer and any replacement parts used on the Megaflo product are authorised Megaflo spare parts.

- The factory fitted temperature and pressure relief valve have not been tampered with or removed.
- The Megaflo product has not been subject to misuse or neglect.
- The Megaflo product has only been used for the storage of wholesome water. Should another substance be put through the product, the warranty will be invalid unless it is part of a disinfectant procedure carried out in accordance with BS EN 806.
- The Megaflo product has not been subjected to frost or freezing temperatures (except for solar collectors which are designed for external installation).
- The Benchmark™ commissioning checklist service record, included in the Megaflo installation instructions has been completed.
- Regular maintenance has been carried out by a competent person/, an approved engineer from Heatrae Sadia or any other part of the Baxi Group Baxi Customer Support approved engineer in accordance with the requirements set out in the maintenance section of the installation instructions.
- Access is available, at reasonable times and upon reasonable notice, to the Megaflo product to allow for any inspection repair or replacement.
- The product is registered within 60 days of purchase. This can be done by telephone, online or by using the registration form provided with the product.
- Evidence of purchase (for example a receipt or delivery note) and date of supply is submitted when making a claim.
- The Megaflo product has not been affected by any cause beyond our reasonable control including, without limitation: an act of God, explosion, flood, fire or accident; war or civil disturbance; strike, industrial action or stoppages of work; any form of government intervention; a third party act or omission including theft or malicious damage; failure by you to give us a correct delivery address or notify us of any change of address.

If any of the following situations occur, the Megaflo Lifetime Warranty* will not apply:

- Any wilful or accidental damage caused by your negligence
- Damage caused as a result of scale.
- Installation not in line with the installer and user manuals provided,
- Failure to comply with installation instructions (whether oral or in writing),
- Misuse of the Megaflo product or alteration of the Megaflo product not in accordance with the requirements set out above.
- Defects which are not reported to us outside of the warranty period on 0345 0701058 or commercialservice@baxiheating.co.uk
- Any third party repair or replacement costs unless those costs have been agreed and authorised by Baxi Customer Support or Heatrae Sadia in writing prior to incurring the costs.
- In relation to the Megaflo Commercial Lifetime Warranty only, we will not be liable for any indirect and consequential losses and any loss of earnings, loss of business, or losses in relation to stress and inconvenience, howsoever caused.

Claims

Defects should be reported to us as soon as you are aware of them. Please report defect to us by contacting 0345 0701058 or commercialservice@baxiheating.co.uk

Notes

We are only able to carry out warranty repair/replacement to Megaflo solar collectors which have safe access and that meet current Health & Safety working at heights requirements. The customer will cover the cost of any safety equipment including but limited to scaffolding and lifting equipment that is required to meet this standard and will appoint a contractor to carry this work out.

Heatrae Sadia accepts no liability for any third party damage.

These warranties do not affect your statutory rights and remedies in relation to the Megaflo products.

Annual service

Annual services are available from Baxi Customer Support, the service division of Heatrae Sadia.

Please contact Baxi Customer Support on 0345 0701058 for details.

*In domestic† properties, lifetime is the period during which the first owner of the Megaflo or new build home continues to own the property. Should the property be sold, the new owner and any subsequent owners will receive a 30 year warranty from the date the original owner purchased the Megaflo or new home with a Megaflo installed. In non-domestic properties lifetime is a period of 30 years from the date of purchase by the original owner and is transferable to any new owner of the property.

†Domestic is any premises not being, or ever having been, wholly or partly utilised for business purposes.

^Non-domestic premises are any premises other than those defined as Domestic.†

All Megaflo warranties are conditional on the installation being carried out in accordance with the installation instructions supplied with the product. These warranties do not affect your statutory rights. Full terms and conditions of these warranty packages are available on request or via www.heatraesadia.com/Megaflo

Heatrae Sadia*, Hurricane Way, Norwich, Norfolk, NR6 6EA

Megaflo may introduce modifications to their products from time to time. Consequentially the details given in this brochure are subject to alteration without notice.

Contacts

Specification Advice Hotline

T: 01603 420220

F: 01603 420229

E: specifier@heatraesadia.com

www.heatraesadia.com

* Heatrae Sadia is a trading name of Baxi Heating UK Limited, Brooks House, Coventry Road, Warwick, CV34 4LL

July 2015

Notes



Customer service

Telephone:
0345 0701058

E-mail:
commercialservice@
baxiheating.co.uk

Megaflo
Hurricane Way
Norwich
Norfolk
NR6 6EA

